

Z2 x8 pcs.

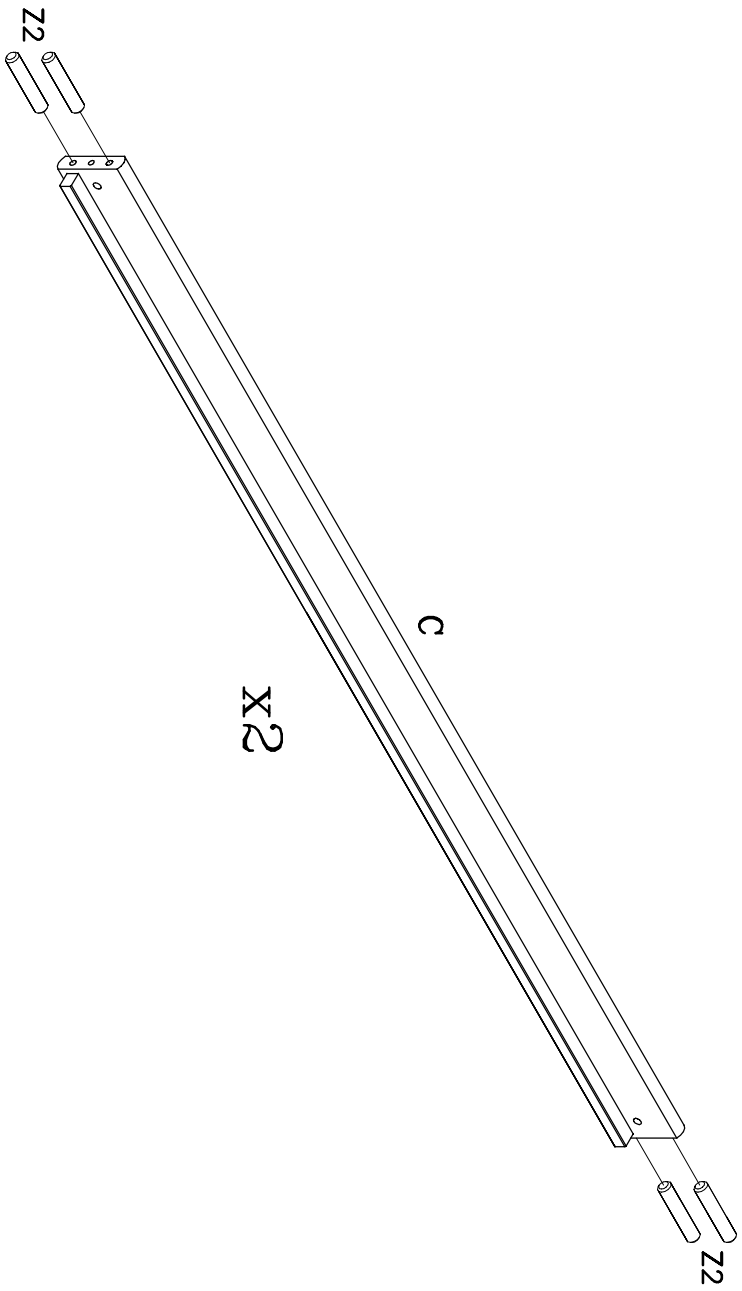

2

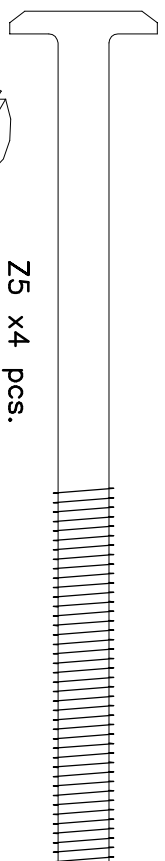

Z5 x4 pcs.

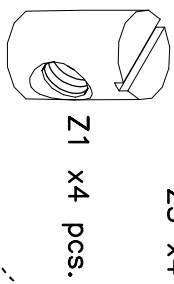

Z1 x4 pcs.

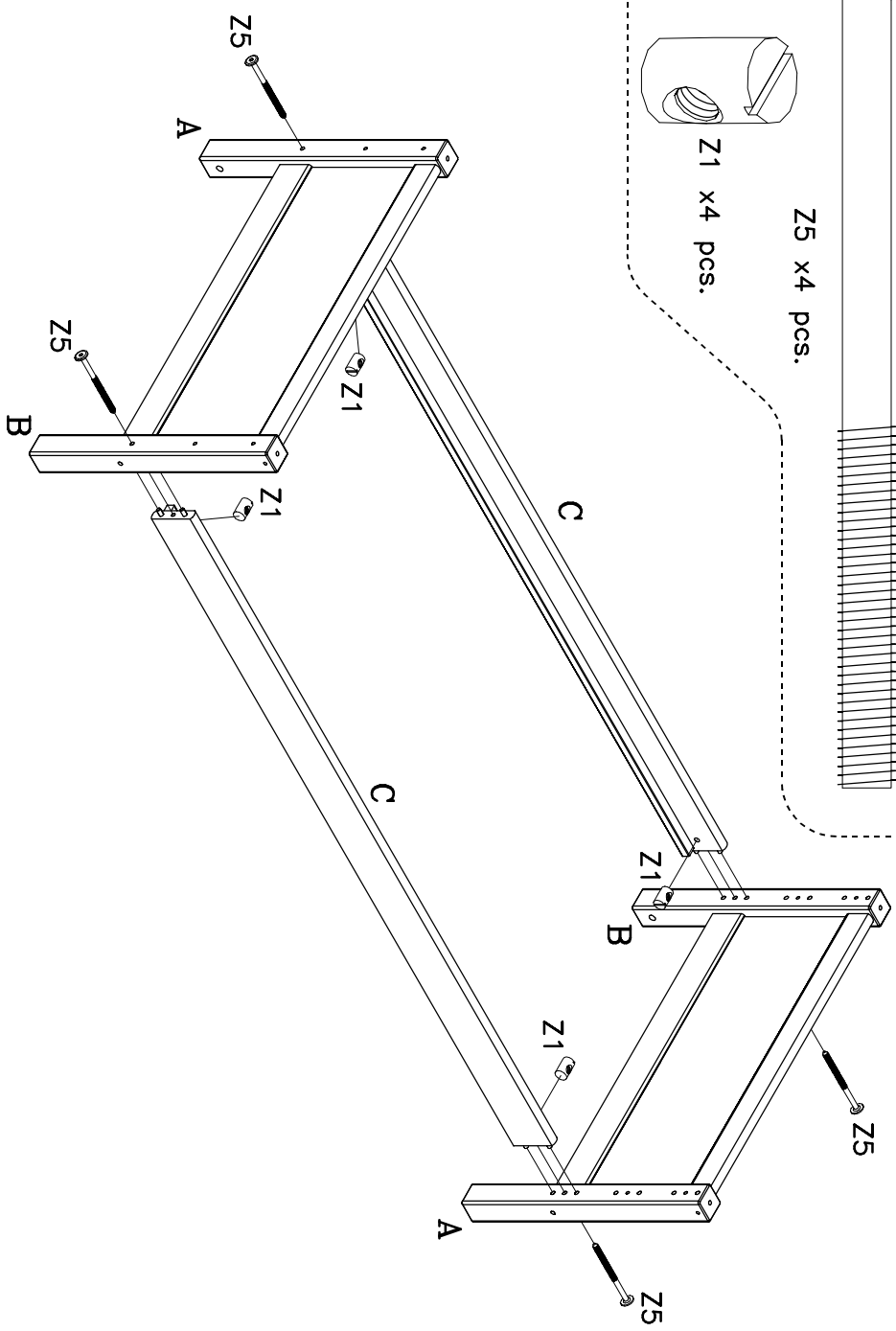

3



Z4 x6 pcs.

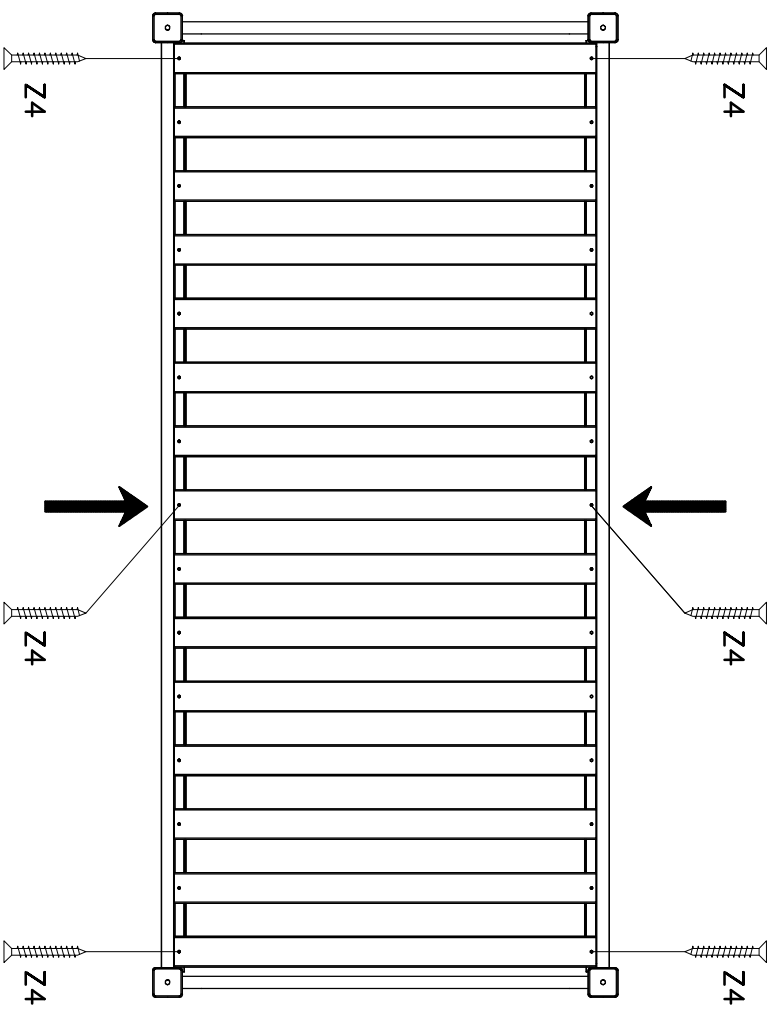

4



Z4 x24 pcs.

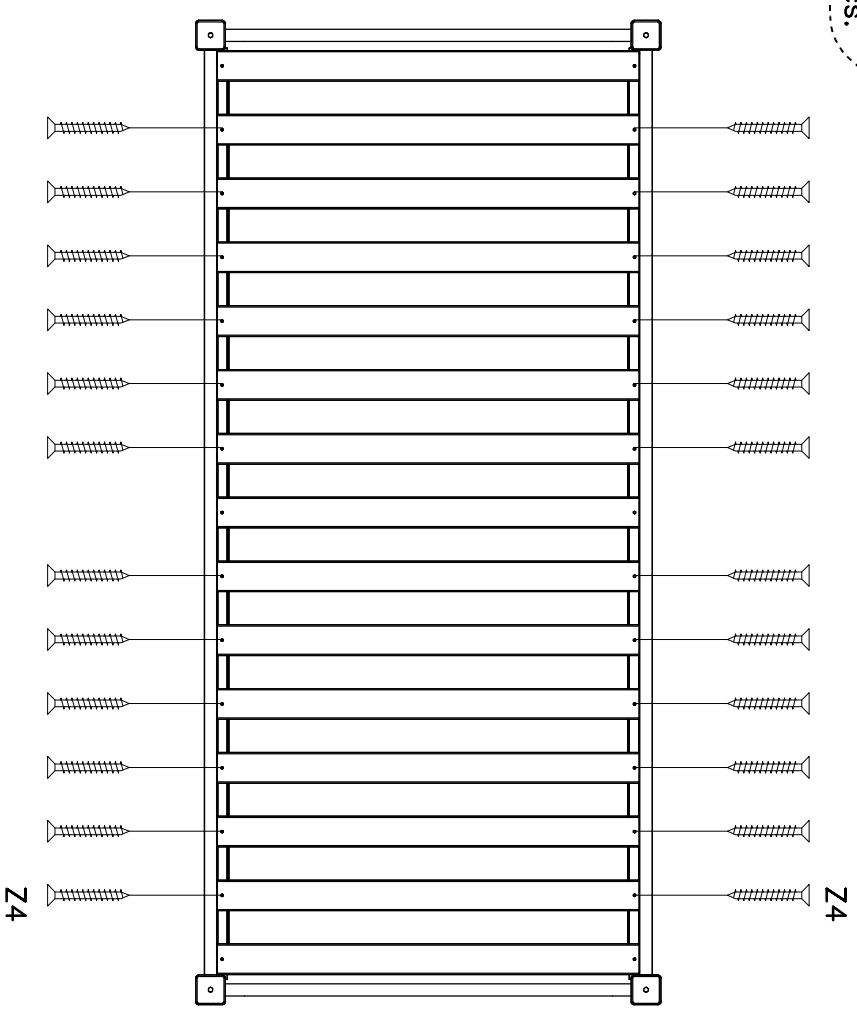

80-20901-18 Pink
 80-20901-40 White
 80-20901-89 Grey

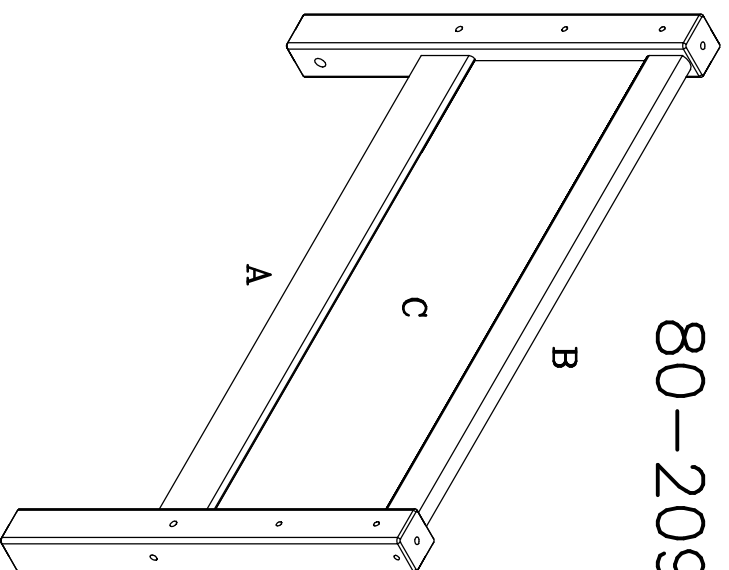

Part no. Réf No	Stock Qty. Dim.	Ware-nr. Part no. Réf No	Mass Dim. Dim.	Image no	See picture no.	Stiehe Bild-nr. See picture no.
12-02608635-40	2 stck/pcs.	12-02608635-40	2 stck/pcs.			
12-02608635-40	2 stck/pcs.	12-02608635-40	2 stck/pcs.			
4301-0808631-18/-40/-89	2 stck/pcs.	4301-0808631-18/-40/-89	2 stck/pcs.			
863x89x26		863x65x26				863x299x8

Before assembling this product, please ensure that all the components supplied comply with the list on this page. All Screw-type fittings can be tightened with this tool.

Avant de commencer l'assemblage, veuillez contrôler si tous les objets indiqués sont présents. Tous les vis peuvent être serrés par cet outil.

Bevor Sie mit dem Aufbau beginnen, kontrollieren Sie ob alle auf der Zeichnung angegebenen Teile vorhanden sind. Bitte verwenden Sie zur Montage einen Kreuzschraub-Ziher und den beiliegenden Innensechskantschlüssel.

Fittings in single / bunk bed box.
 Beschläge im Einzel- / Etagenbett Karton.
 Raccords en lit simple / lit superposé.
 Fittings in het enkelspel / stapelbed boxen.

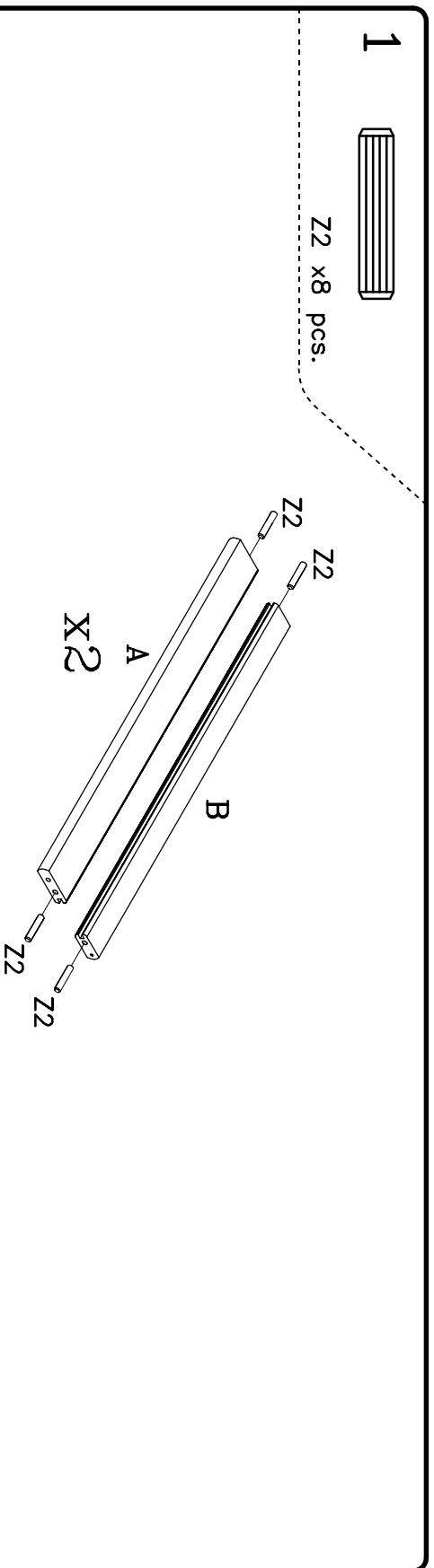

Bunk bed only. Nur Etagen Bett.
 Lits superposés seulement. Alleen stapelbed

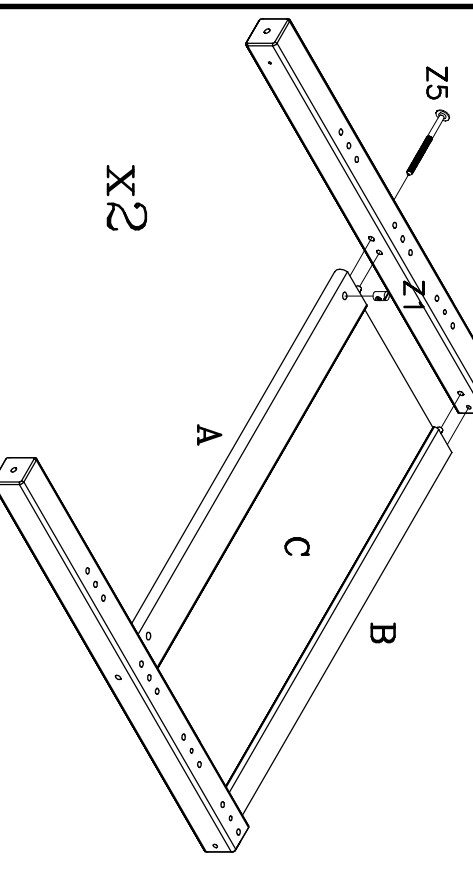
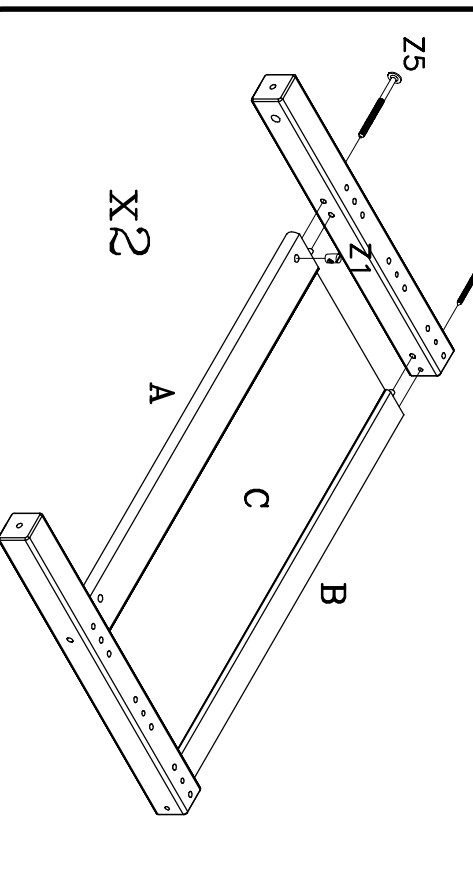
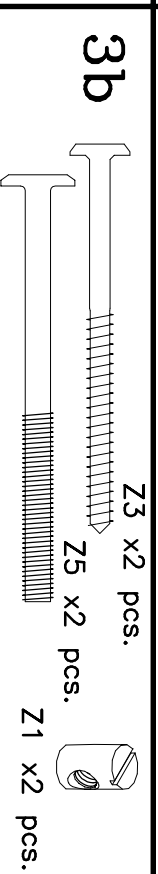
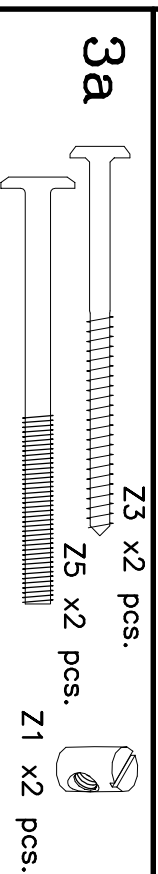
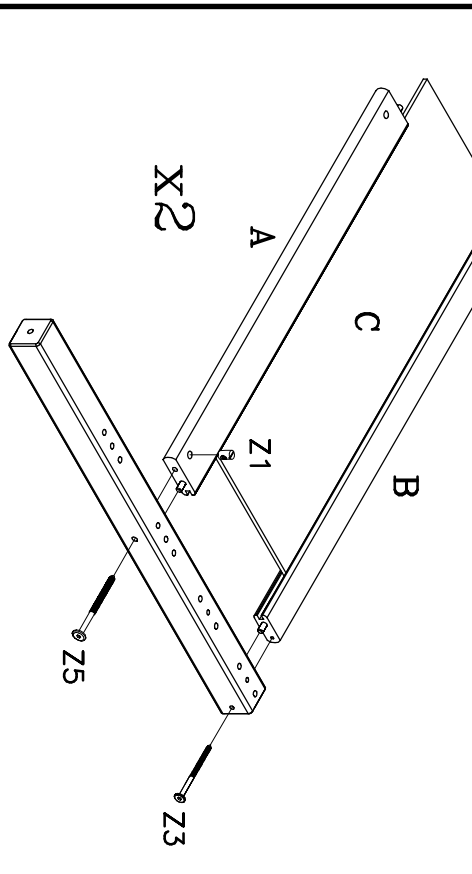
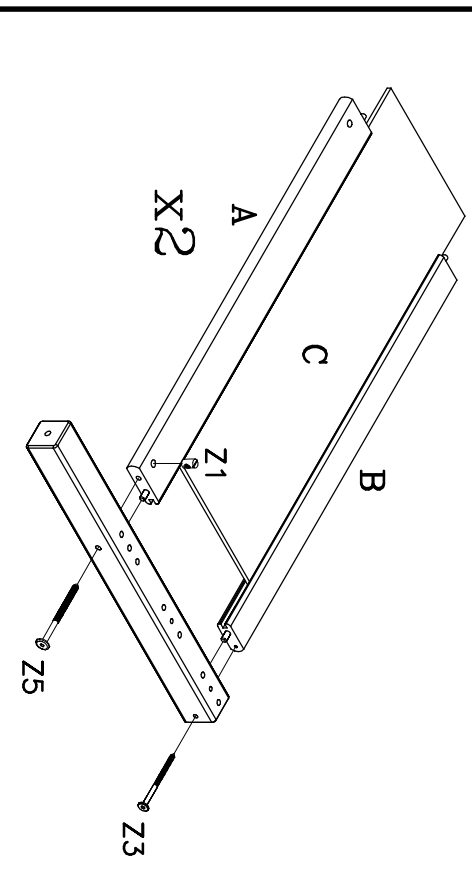
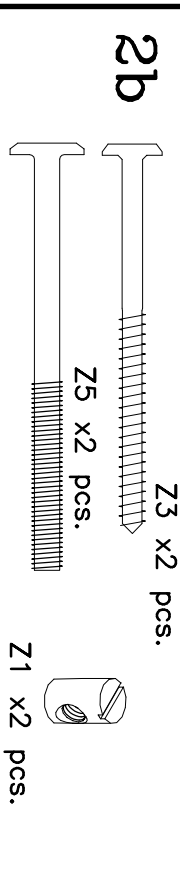
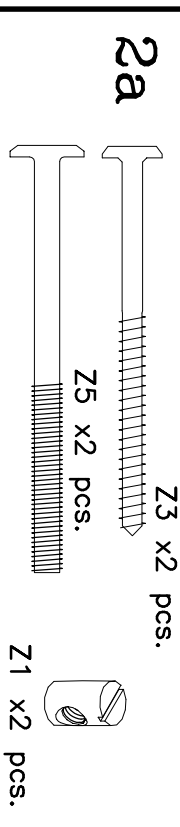

80-20902-40

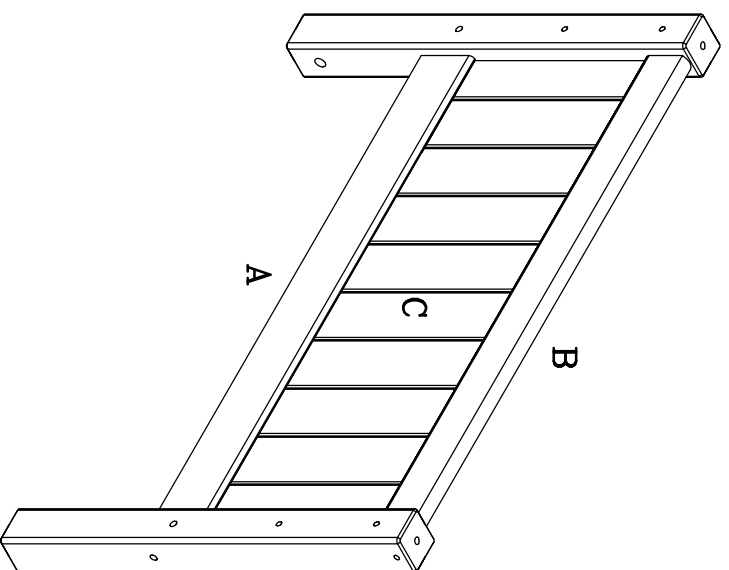

	12-02608636-40	12-02608635-40	4301-0808632-40	
				Ware-nr. Part no. Réf No
	2 stck./pcs.	2 stck./pcs.		Stock. Qty. Qté.
				Mass Dim. Dim.
	2 stck./pcs.	2 stck./pcs.	2 stck./pcs.	
A	863x89x26	863x65x26	863x299x8	

Fittings in single / bunk bed box.
 Beschläge im Einzel- / Etagenbett Karton.
 Raccords en lit simple / lit superposé.
 Fittings in het enkelspel / stapelbed boxen.

1



Z2 x8 pcs.

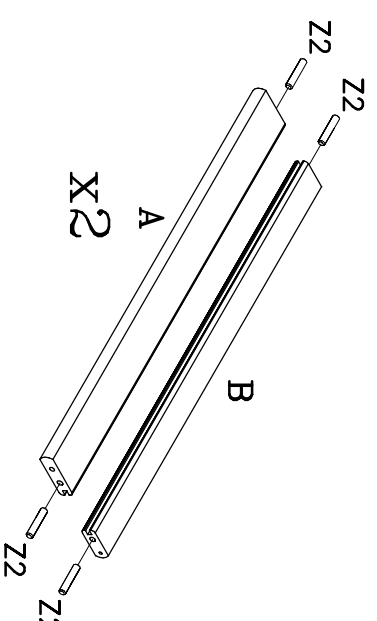

Bunk bed only. Nur Etagen Bett.
 Lits superposés seulement. Alleen stapelbed

2a

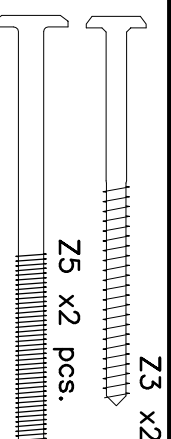

Z3 x2 pcs.

Z5 x2 pcs.

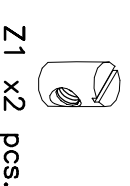

Z1 x2 pcs.

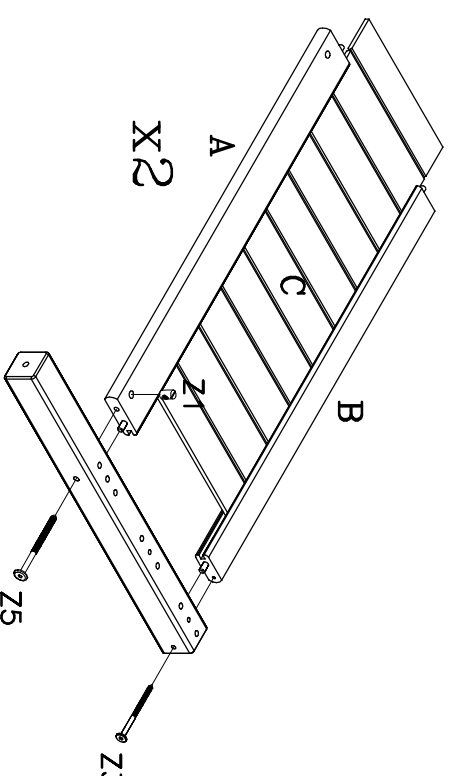

2b

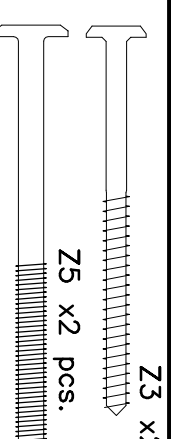

Z3 x2 pcs.

Z5 x2 pcs.

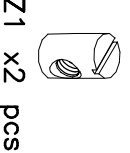

Z1 x2 pcs.

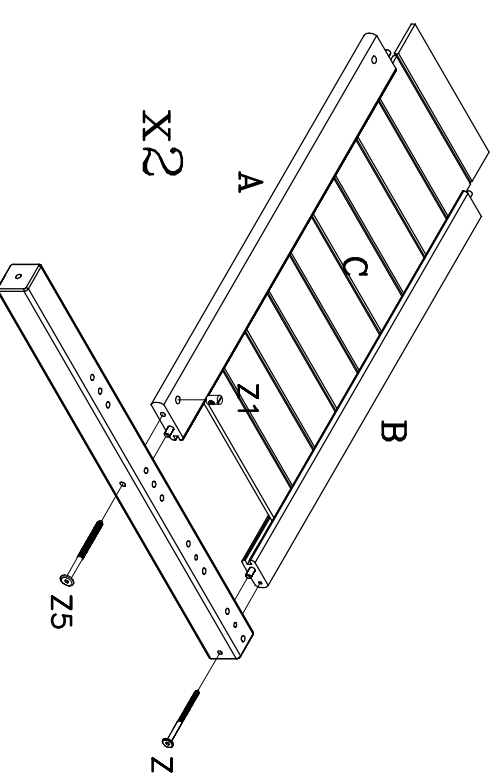

3a

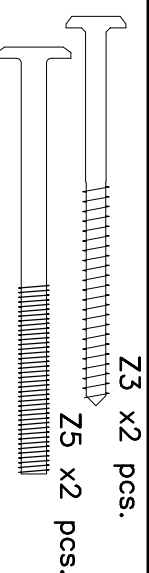

Z3 x2 pcs.

Z5 x2 pcs.

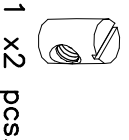

Z1 x2 pcs.

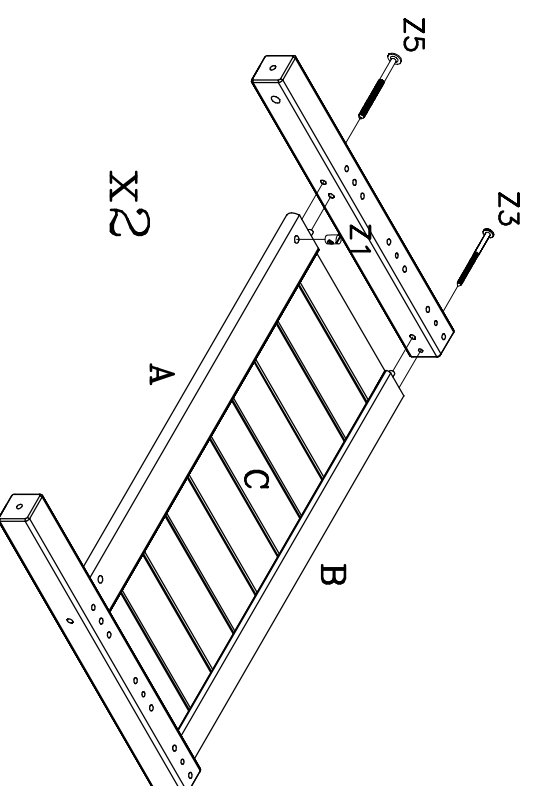

3b

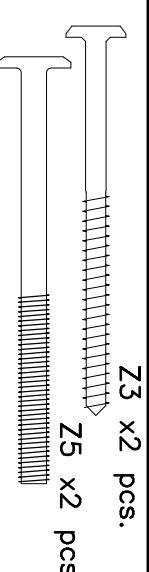

Z3 x2 pcs.

Z5 x2 pcs.

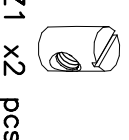

Z1 x2 pcs.

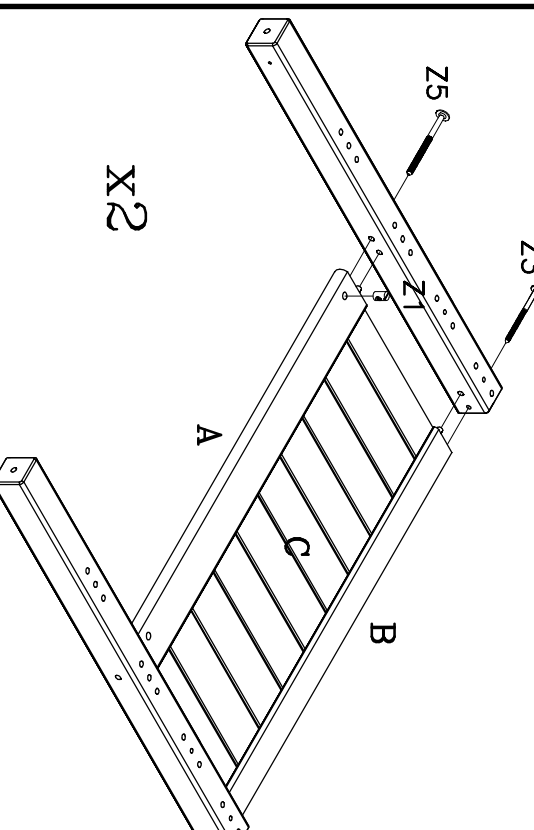

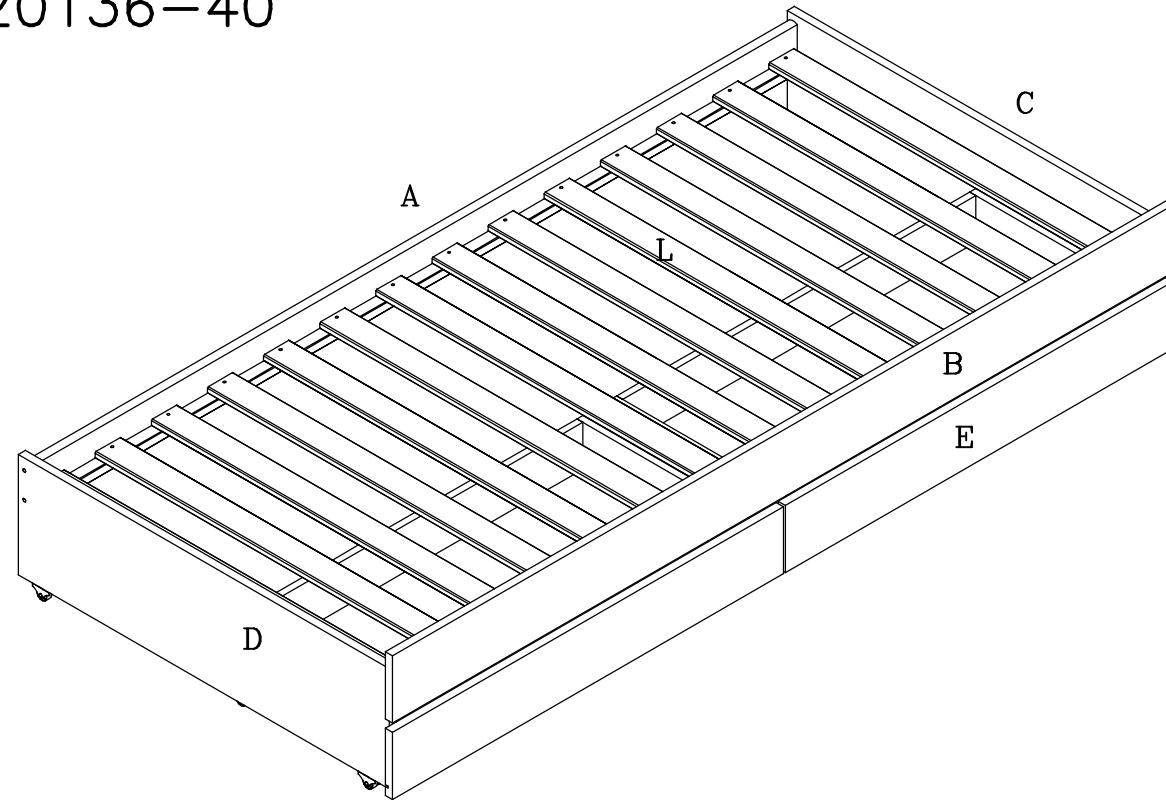

(GB): MAINTENANCE INSTRUCTIONS:
Screws and bolts should from time to time be retightened.
CLEANING:
LACQUERED: Wooden, lacquered and painted as well as laminated surfaces should be wiped over with a cloth and a mild soap.
OIL: Oiled surfaces can be cleaned with soapy water, e.g. brown soap. Wipe with a clean cloth.
To maintain the natural life in the furniture which is provided by the oil treatment, we recommend an oil aftercare of the furniture 1-2 times a year. The colourless natural oil for maintenance of oil-treated furniture is available at your local furniture store.

(D): PFLEGEHINWEIS:
Schrauben und Bolzen sollten regelmässig nachgezogen werden.
REINIGUNG:
LACKIERTE MÖBEL: Lackierte Holzoberflächen können mit einem sauberen Lappen und mildes Seifenwasser gereinigt werden.
GEÖLTE MÖBEL: Geölte Holzoberflächen können mit einem sauberen Lappen und Seifenwasser, z.B. Schmierseife, gereinigt werden. Um das natürliche Aussehen des Holzes zu bewahren, ist eine Öl-Nachbehandlung vom Möbelstück 1 bis 2 Mal pro Jahr empfehlenswert. Das farblose Öl, für die Nachbehandlung der Möbel, kann in Ihrem Möbelgeschäft gekauft werden.

(F): CONSEILS D'ENTRETIEN:
Votre lit doit être vérifié périodiquement afin de reserrer les vis.
NETTOYAGE:
LAQUÉ: Les surfaces bois, laqués, peintes et laminés peuvent être essuyées avec un chiffon et un savon doux.
HUILE: Des surfaces huilées peuvent être nettoyées avec l'eau savonneuse, par ex. savon de Marseille, et essuyées avec un chiffon propre. Pour maintenir l'aspect naturel du bois, nous vous recommandons de traiter avec une huile d'ameublement 1-2 fois par an. L'huile naturelle sans colorant peut être achetée dans votre magasin de meuble.

<p>Before assembling this product, please ensure that all the components supplied comply with the list on this page. All Screw-type fittings can be tightened with this tool.</p>	<p>Avant de commencer l'assemblage, veuillez contrôler si tous les objets indiqués sont présents. Tous les vis peuvent être serrés par cet outil.</p>	<p>Bevor Sie mit dem Aufbau beginnen, kontrollieren Sie ob alle auf der Zeichnung angegebenen Teile vorhanden sind. Bitte verwenden Sie zur Montage einen Kreuzschraubzieher und den beiliegenden Innensechskantschlüssel.</p>		<p>Ware-nr. Part no. Réf No</p>	<p>Stck. Qty. Qté.</p>
<p>Siehe Bild-nr. See picture no. Image no</p>				<p>Mass Dim. Dim.</p>	

<p>1331-19005 1 stck/pcs.</p> <p>A 1900x89x20</p>	<p>1331-19554-40 1 stck/pcs.</p> <p>B 1955x145x18</p>	<p>15-01809251-40 1 stck/pcs.</p> <p>C 925x260x18</p>	<p>15-01809252-40 1 stck/pcs.</p> <p>D 925x260x18</p>	<p>15-01809751-40 2 stck/pcs.</p> <p>E 975x145x18</p>	<p>12-01508811 2 stck/pcs.</p> <p>F 881x115x15</p>	<p>12-01504501 2 stck/pcs.</p> <p>G 450x115x15</p>	<p>12-01504502 2 stck/pcs.</p> <p>H 450x115x15</p>		
<p>3908-70050 4 stck/pcs.</p> <p>Z1 ø7x50 mm.</p>	<p>3902-35012 24 stck/pcs.</p> <p>Z2 3.5x12 mm.</p>	<p>3901-40030 28 stck/pcs.</p> <p>Z3 4x30 mm.</p>	<p>3901-40060 4 stck/pcs.</p> <p>Z4 4x60 mm.</p>	<p>3933-15010 12 stck/pcs.</p> <p>Z9 ø15x9.5 mm.</p>	<p>4309-0308921 2 stck/pcs.</p> <p>I 892x446/223x3</p>	<p>12-02600701-40 1 stck/pcs.</p> <p>J 70x65x26</p>	<p>12-06301401-40 4 stck/pcs.</p> <p>K 140x63x63</p>	<p>12-01508971 14 stck/pcs.</p> <p>L 897x65x14,7</p>	
<p>3901-35040 8 stck/pcs.</p> <p>Z5 3.5x40 mm.</p>	<p>3917-10012 4 stck/pcs.</p> <p>Z6 M10x12 mm.</p>	<p>3922-10028 4 stck/pcs.</p> <p>Z7 M10/ø15x28 mm.</p>	<p>3930-08030 6 stck/pcs.</p> <p>Z8 ø8x30 mm.</p>	<p>3933-15028 4 stck/pcs.</p> <p>Z10 ø15x28 mm.</p>	<p>4033-004 1 stck/pcs.</p> <p>Z11 ø4 mm.</p>	<p>4003-002 12 stck/pcs.</p> <p>Z12</p>	<p>3934-10115 4 stck/pcs.</p> <p>Z13 M10/ø10x115 mm.</p>	<p>3938-00016-2 4 stck/pcs.</p> <p>Z14 ø16x5.8 mm.</p>	<p>3940-000201 2 stck/pcs.</p> <p>Z15 ø18/ø4.5x20 mm.</p>
			<p>4005-039 2 stck/pcs.</p> <p>Z16 50x10x4 mm.</p>	<p>4020-005 12 stck/pcs.</p> <p>Z17 ø7x34 mm.</p>					

1

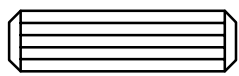

Z8x6 pcs.

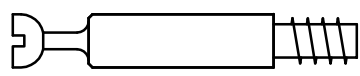

Z17x12 pcs.

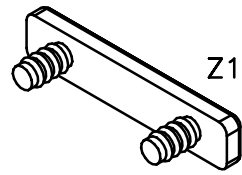

Z16x2 pcs.

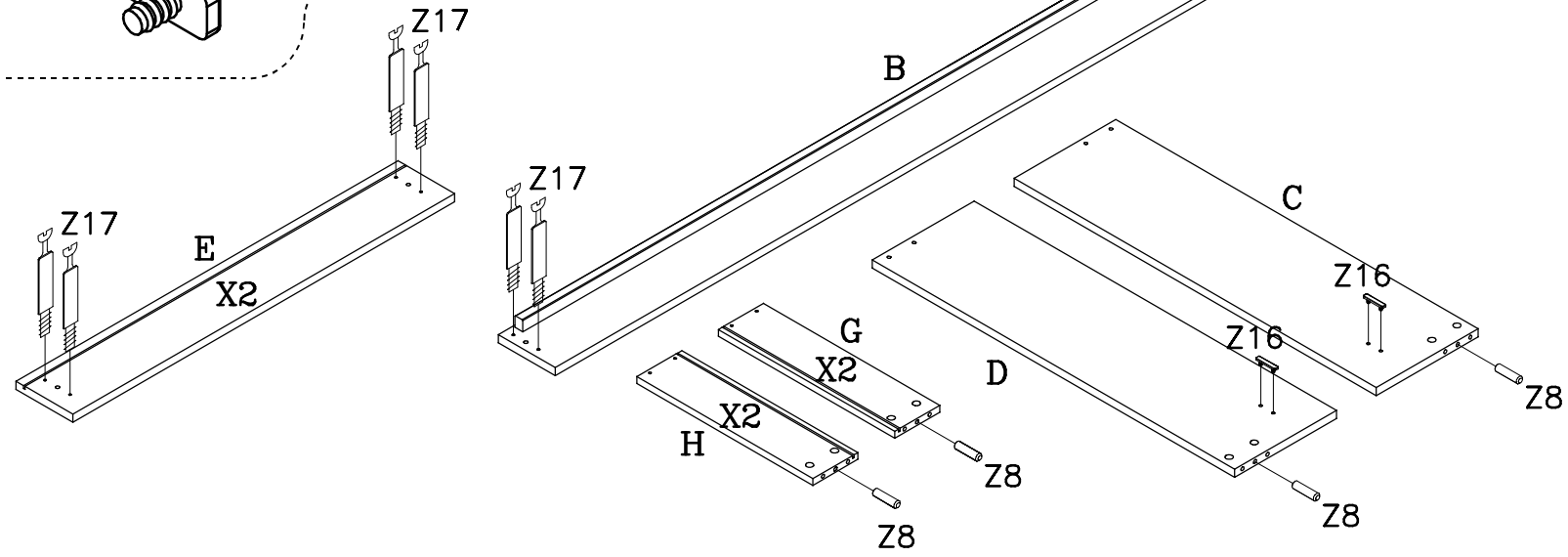

2

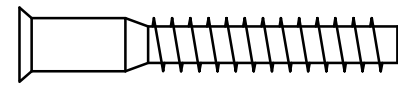

Z1x4 pcs.

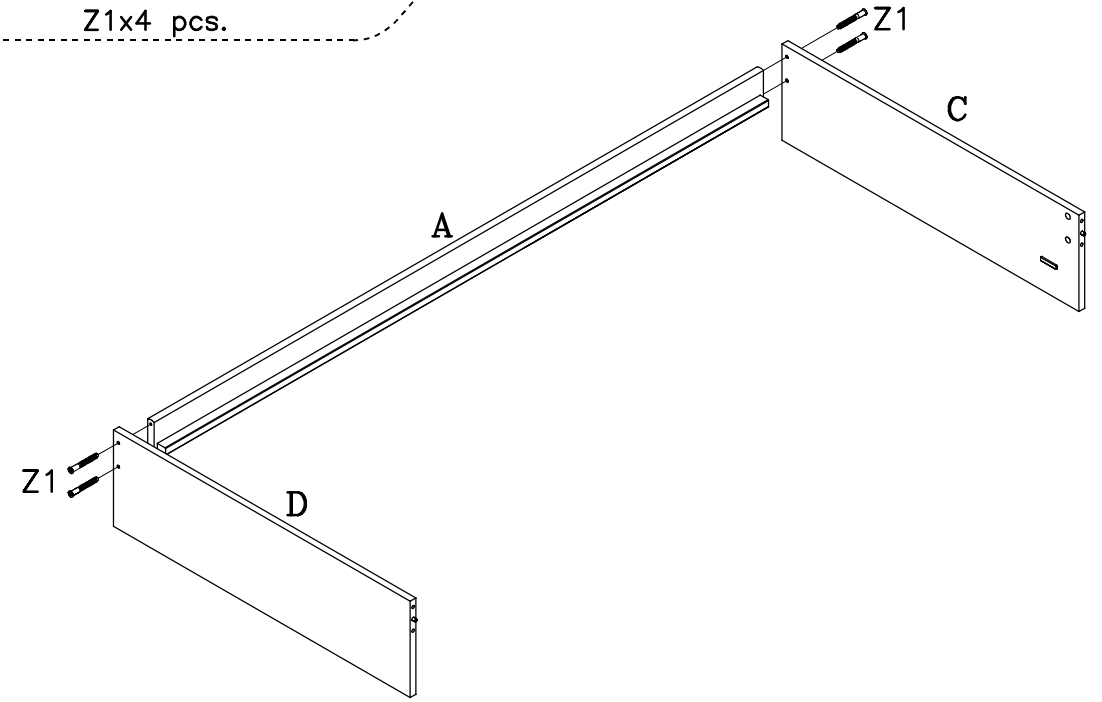

3



Z9x4 pcs.

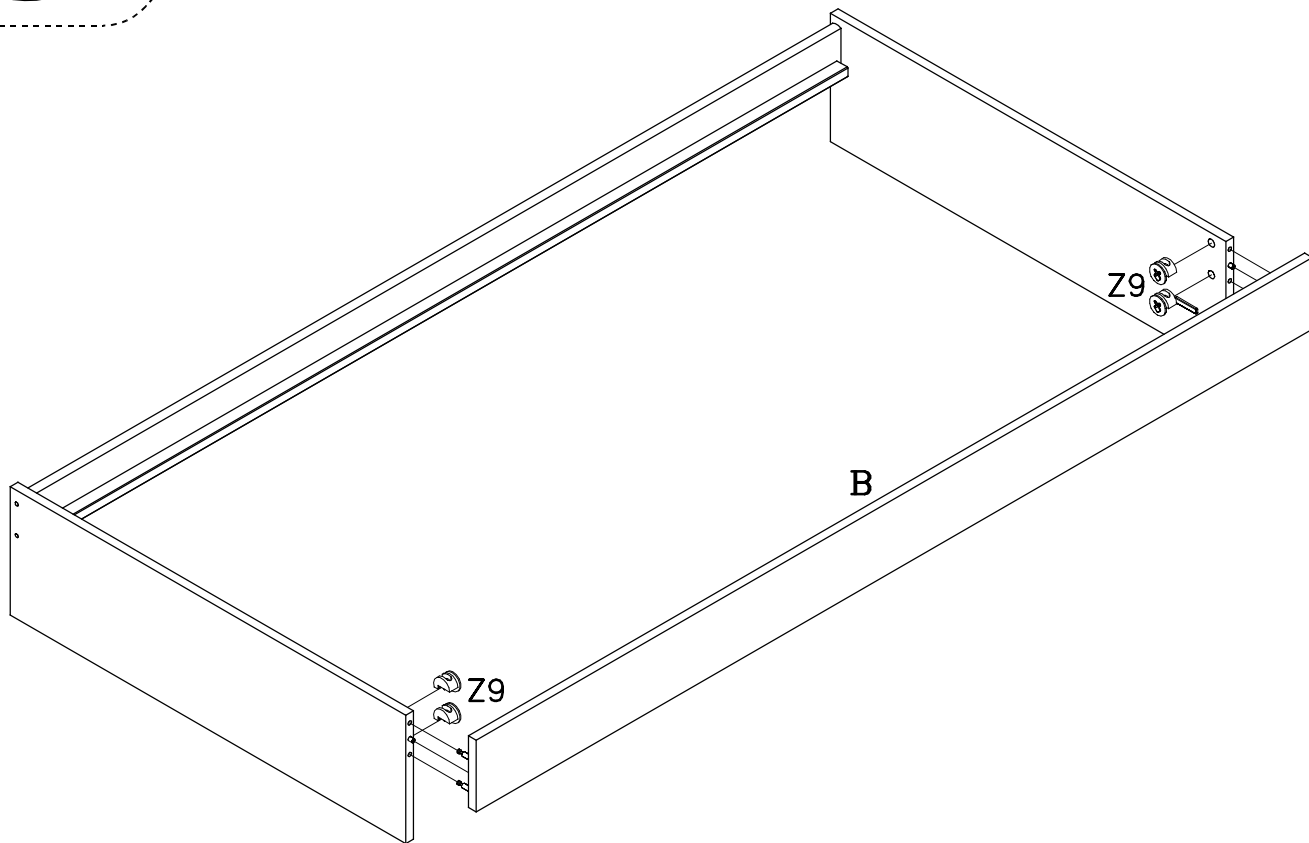

4

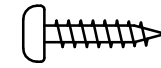

Z2x8 pcs.



Z4x2 pcs.

