

ASSEMBLY INSTRUCTIONS

1
9

MODEL : CK 6232

PRODUCT SIZE : 1186mm(L) x 424mm(W) x 700mm(H)

Thank you for purchasing this product. Before starting assembly we suggest you spend a short time reading through this leaflet, then follow the simple step by step guide.
Two persons are needed to assemble this product.



* Approximately 1 Hours



* 2 People Required

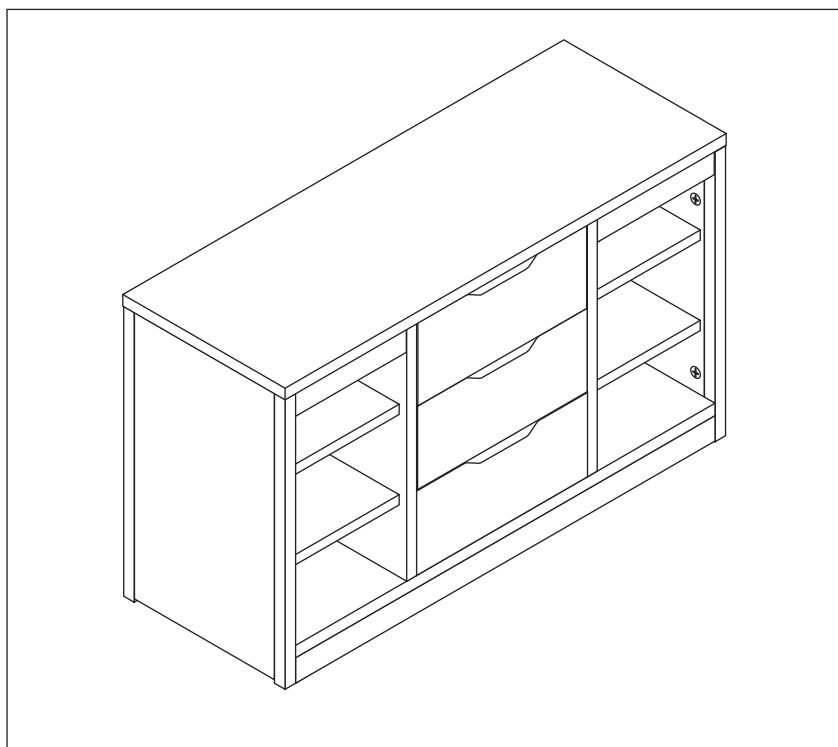

Ensure that you check regularly that all bolt are securely fastened and all components are in place.

If spare parts are required, contact your dealer. Do not use substitute part.

This instructions should be kept in a safe place for future reference.

Tools Required For Assembly



Philips Screw Driver

Tools Not Use

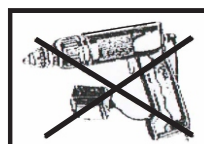

DO NOT USE POWER TOOLS TO ASSEMBLE THIS PRODUCT. USE OF POWER TOOLS WILL INVALIDATE ANY CLAIM AND MAY DAMAGE THIS PRODUCT MAKING IT UNSAFE.











DO NOT USE HAMMER

PARTS LIST

2	9
---	---

Model: CK 6232

Carton 1 of 1			Hardware		
No.	Part Name	Pcs	No.	Part Name	Pcs
①	PLINTH PANEL (CABINET)	1	Ⓐ	Cam 	46
②	BOTTOM PANEL (CABINET)	1	Ⓑ	Cam Stud (5137) 	36
③	CENTER PANEL (CABINET)	1	Ⓒ	M8 x 25mm Wood Dowel 	67
④	CENTER PANEL (CABINET)	1	Ⓓ	15mm Chipboard Screw 	30
⑤	SUPPORT PANEL (CABINET)	4	Ⓔ	38mm Chipboard Screw 	12
⑥	FRONT PANEL (CABINET)	2	Ⓕ	45mm Chipboard Screw 	4
⑦	LEFT PANEL (CABINET)	1	Ⓖ	14" Drawer Slide 	3set
⑧	LEFT POST BACK (CABINET)	1	Ⓗ	Cam Stud (05961) 	10
⑨	LEFT POST FRONT (CABINET)	1			
⑩	RIGHT PANEL (CABINET)	1			
⑪	RIGHT POST BACK (CABINET)	1			
⑫	RIGHT POST FRONT (CABINET)	1			
⑬	BACK PANEL (CABINET)	1			
⑭	TOP PANEL (CABINET)	1			
⑮	BACK PANEL (DRAWER)	3			
⑯	LEFT PANEL (DRAWER)	3			
⑰	RIGHT PANEL (DRAWER)	3			
⑱	BOTTOM PANEL (DRAWER)	3			
⑲	FRONT PANEL (DRAWER)	3			

CAUTION

There are many small components used in the construction of this unit. These loose items should be kept away from young children whilst assembling your unit. As an extra precaution, screw cover caps should be permanently fixed in position. (Where applicable)

USEFUL HINTS & TIPS

Two people will be required to assemble this unit

Please keep this assembly instruction for future reference

PARTS LIST

3
9

Model: CK 6232

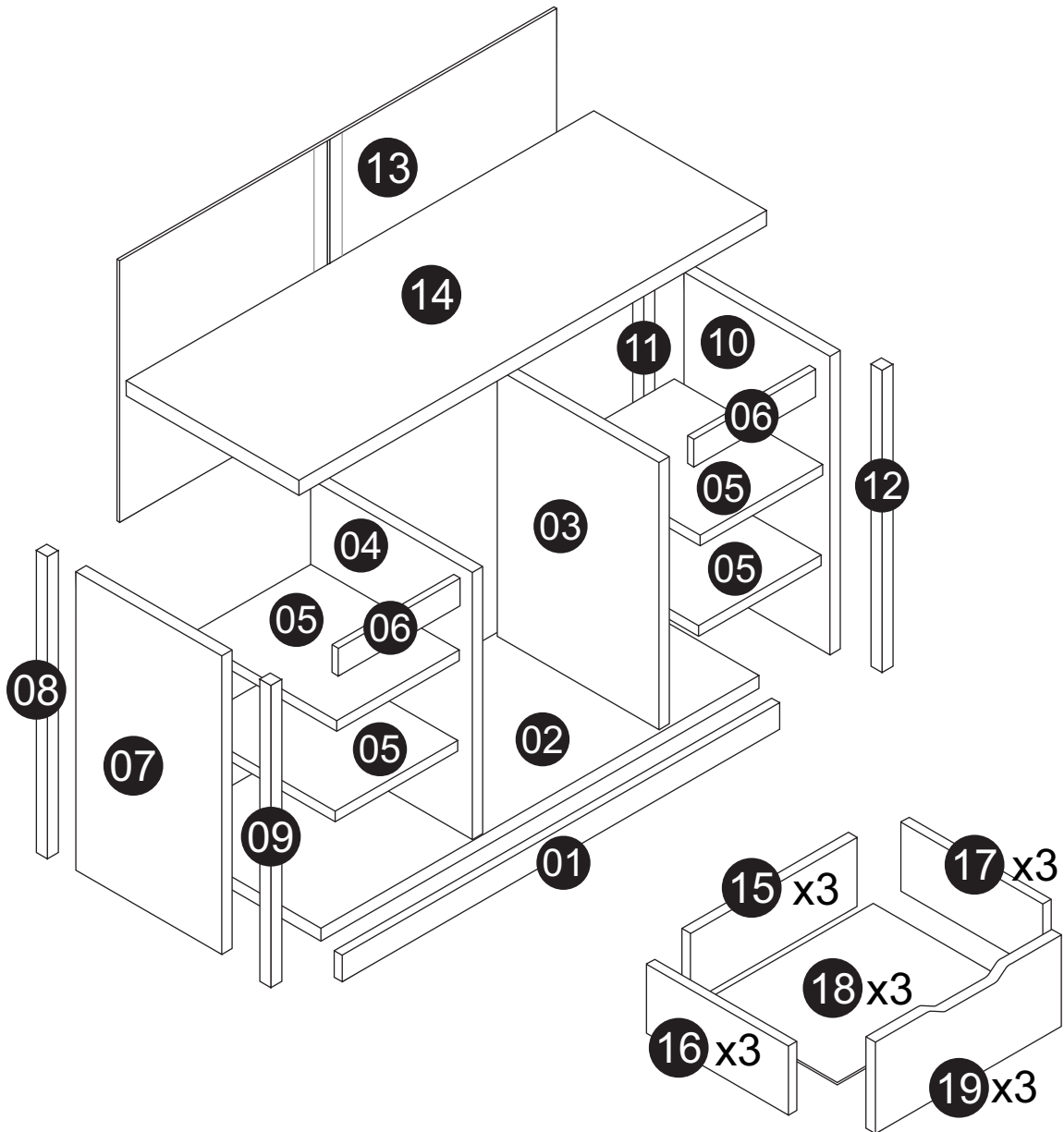

GUIDE TO ASSEMBLY

Model: CK 6232

STEP 1

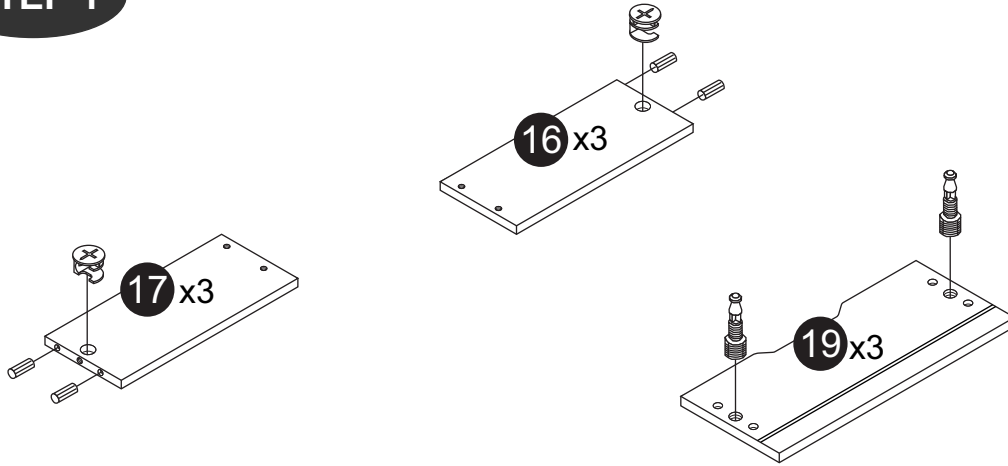

A x 6



B x 6



C x 12

STEP 2

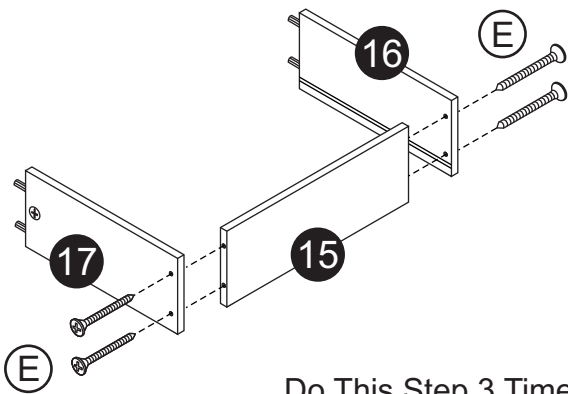

E x 12

Do This Step 3 Times

STEP 3

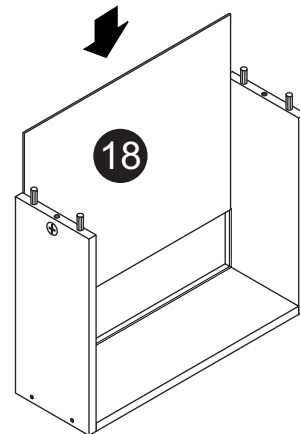

Do This Step 3 Times

STEP 4

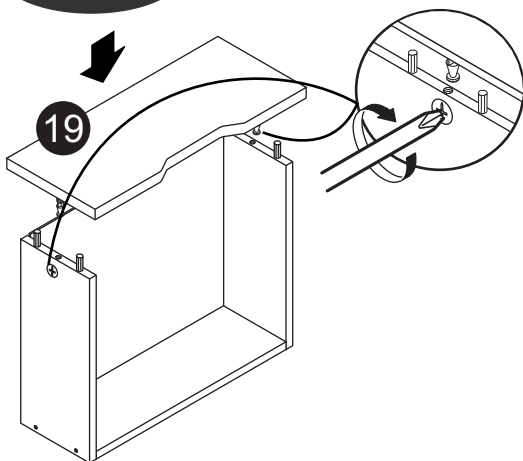

Do This Step 3 Times

STEP 5

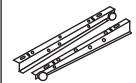
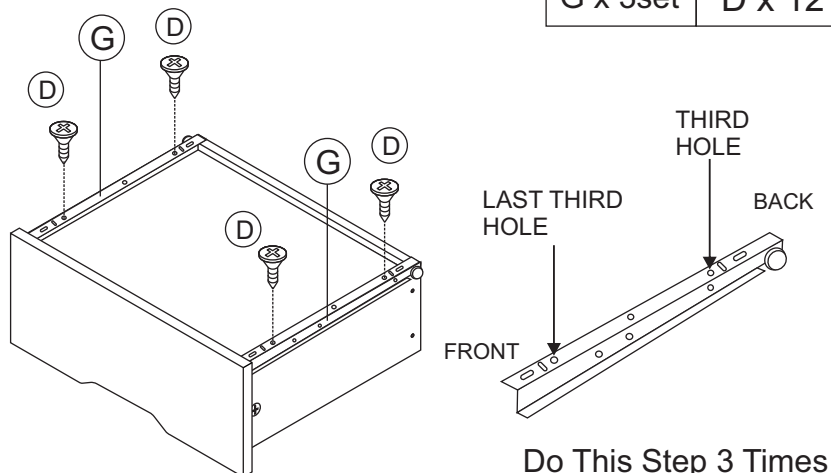

G x 3set



D x 12

Do This Step 3 Times

GUIDE TO ASSEMBLY

5
9

Model: CK 6232

STEP 6

To Assembly the Drawer Slide, Please Follow Step as Below

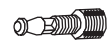
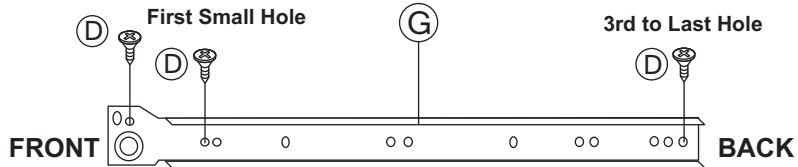

B x 10



A x 28



D x 18



C x 39





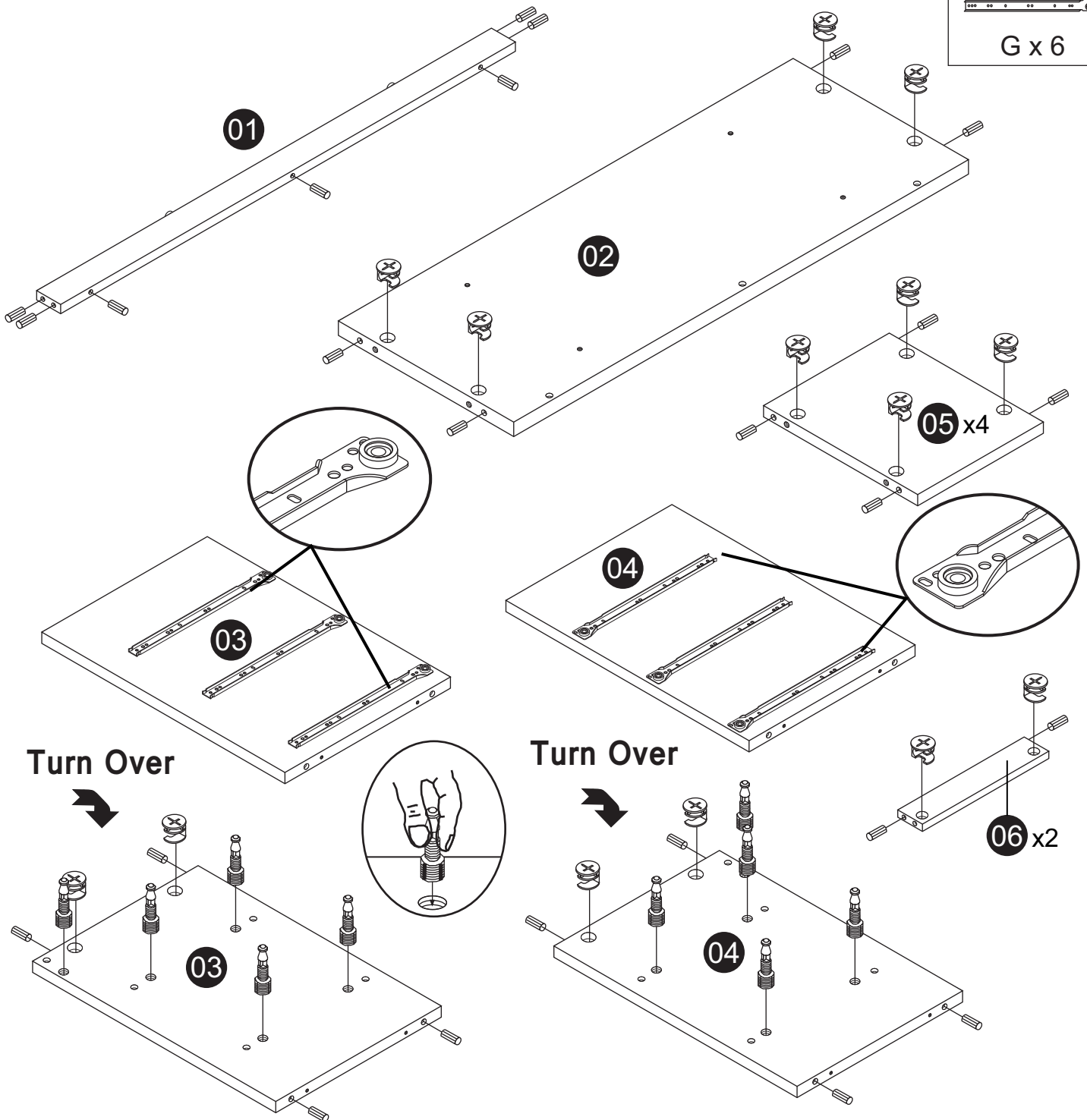

G x 6



GUIDE TO ASSEMBLY

Model: CK 6232

STEP 7

	
A x 12	B x 20
	
H x 10	C x 16

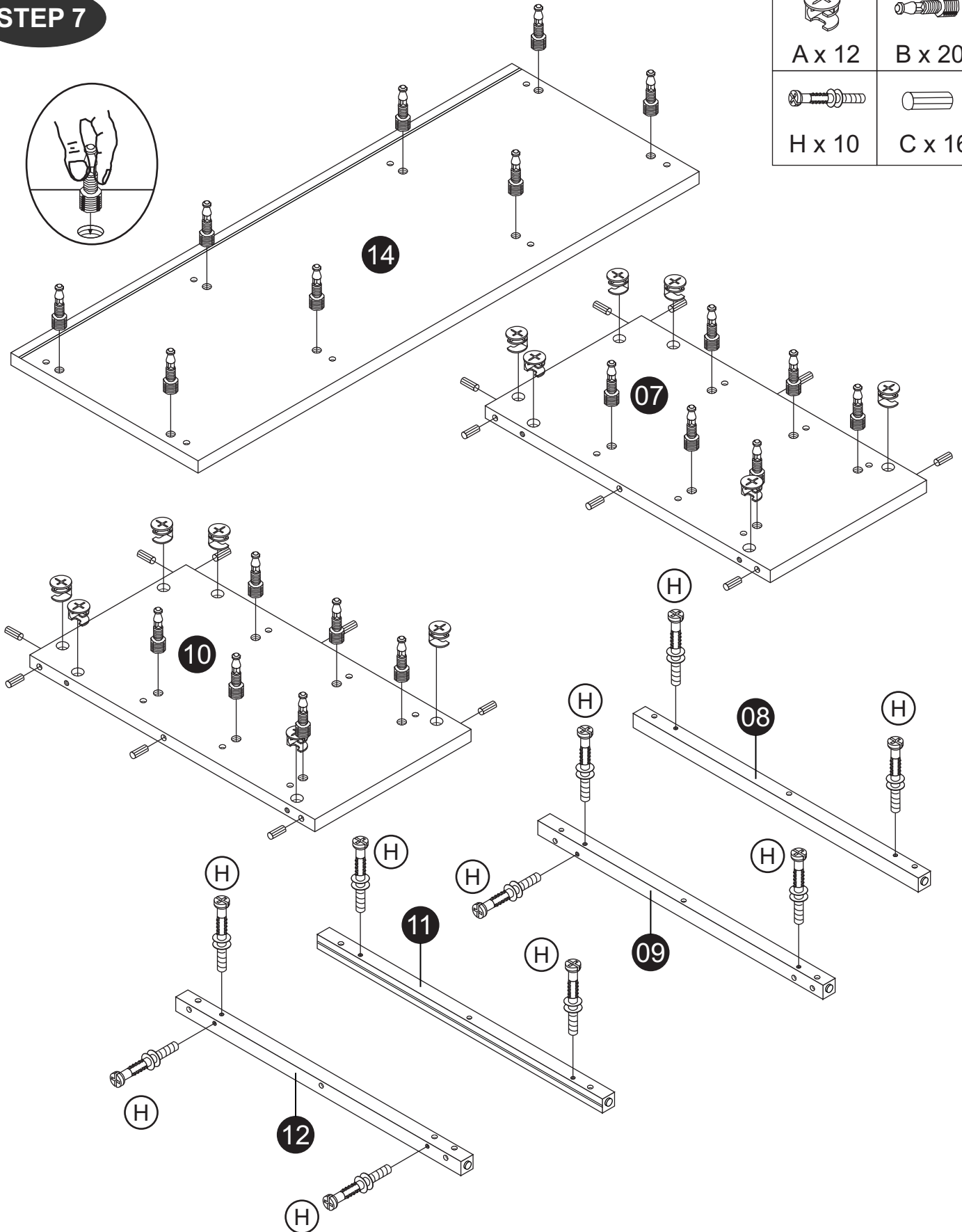

GUIDE TO ASSEMBLY

Model: CK 6232

STEP 8

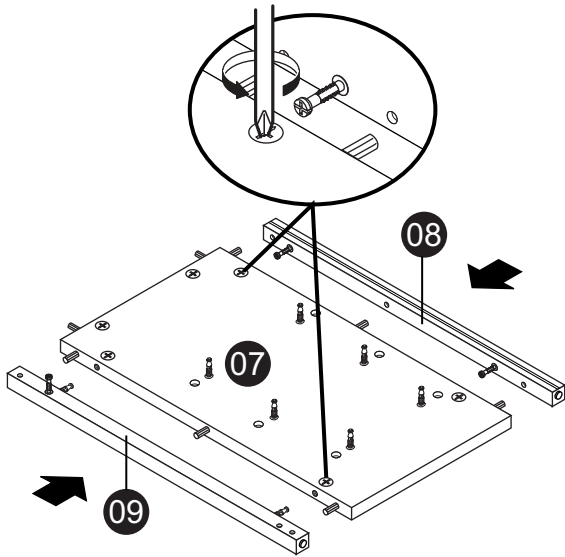

STEP 9

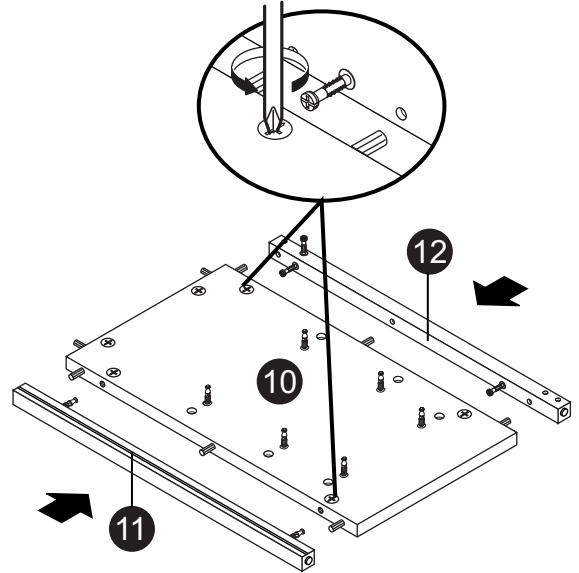

STEP 10

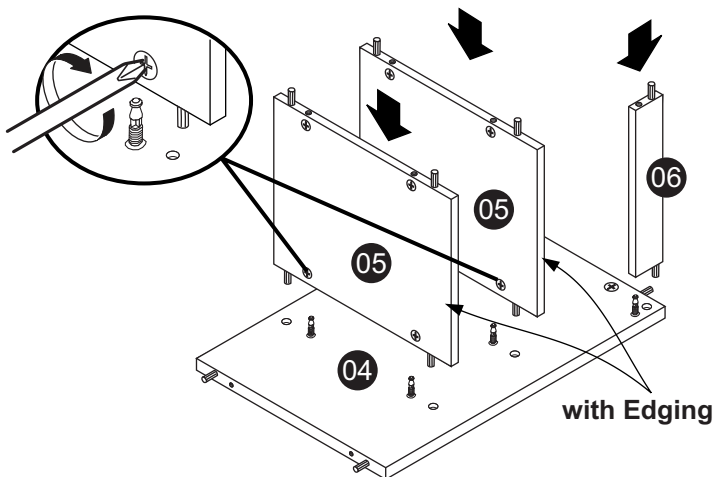

STEP 11

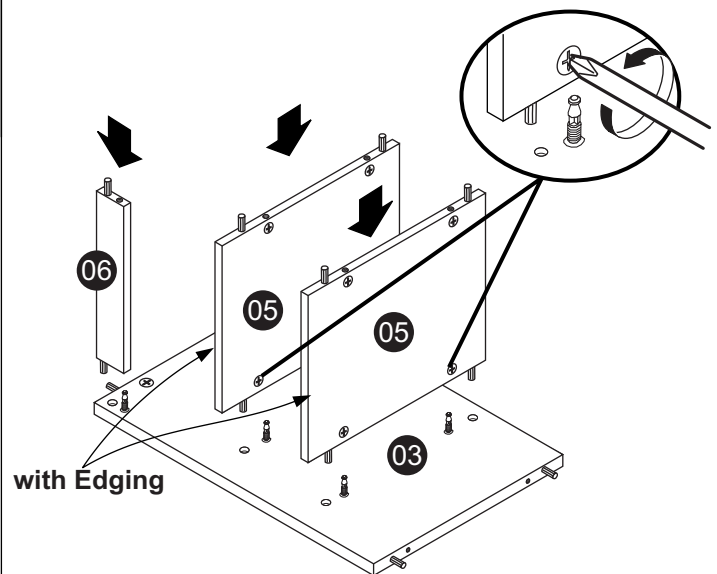

GUIDE TO ASSEMBLY

8
9

Model: CK 6232

STEP 12

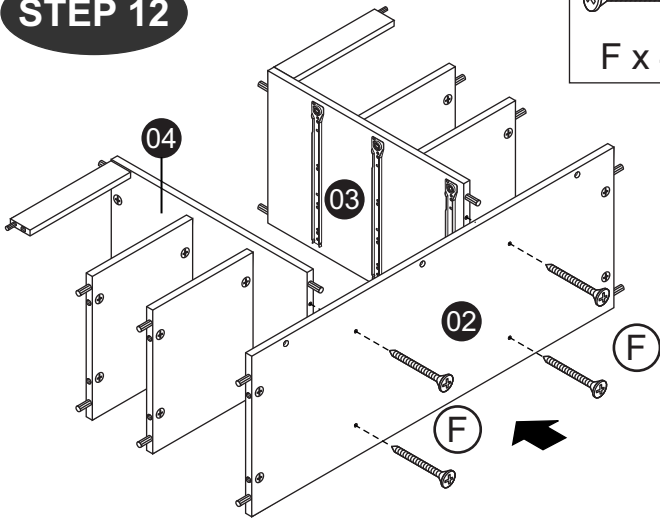
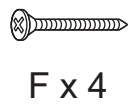

STEP 13

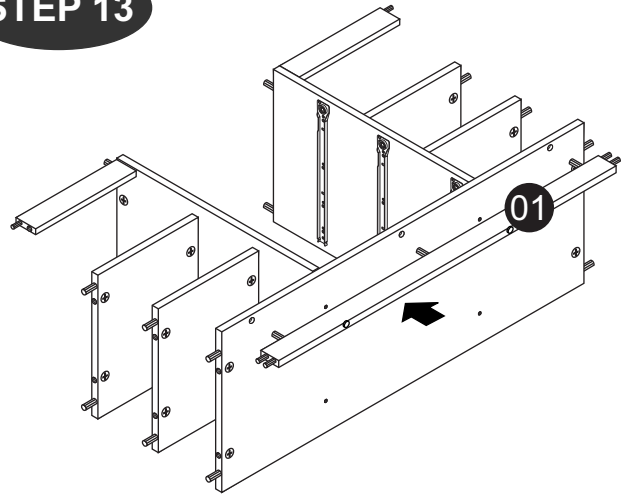

STEP 14

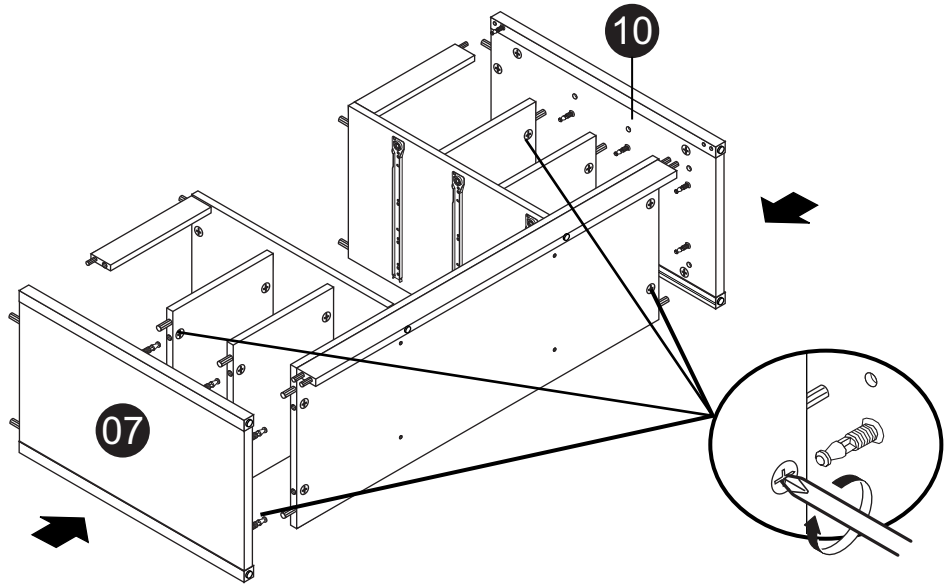

STEP 15

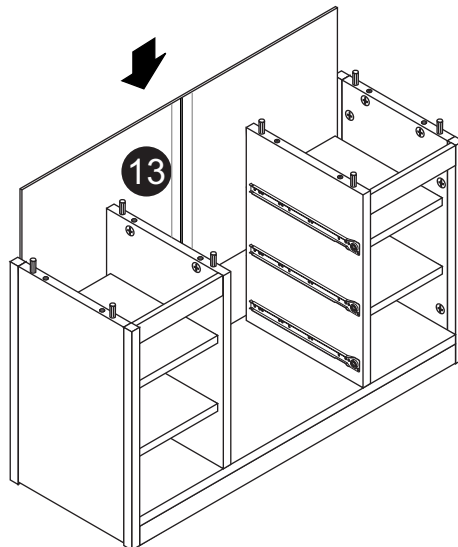

GUIDE TO ASSEMBLY

Model: CK 6232

STEP 16

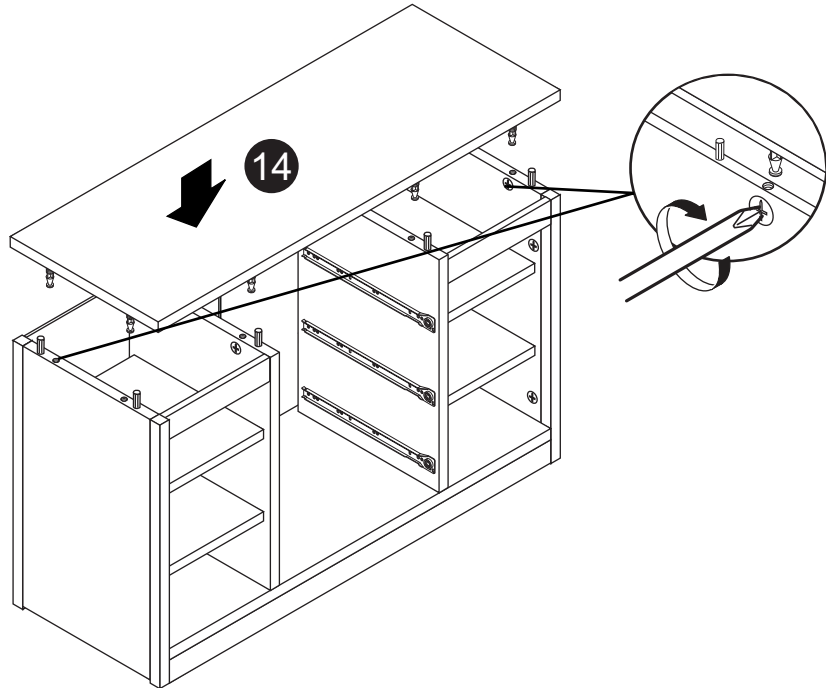

STEP 17

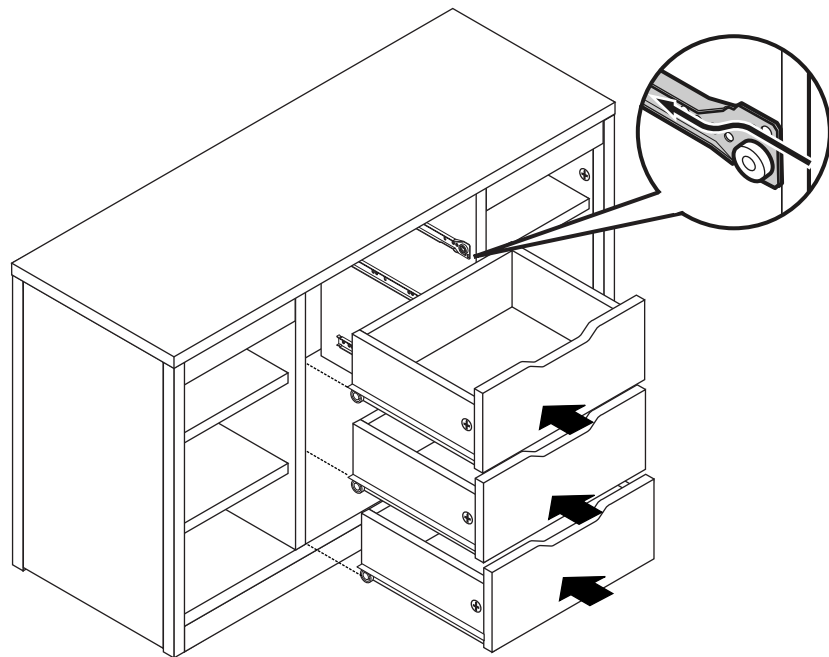

ASSEMBLY INSTRUCTIONS

1
14

MODEL : CK 6216
PRODUCT SIZE : 920mm x 1900mm

Thank you for purchasing this product. Before starting assembly we suggest you spend a short time reading through this leaflet, then follow the simple step by step guide.
Two persons are needed to assemble this product.



* Approximately 1 Hours



* 2 People Required

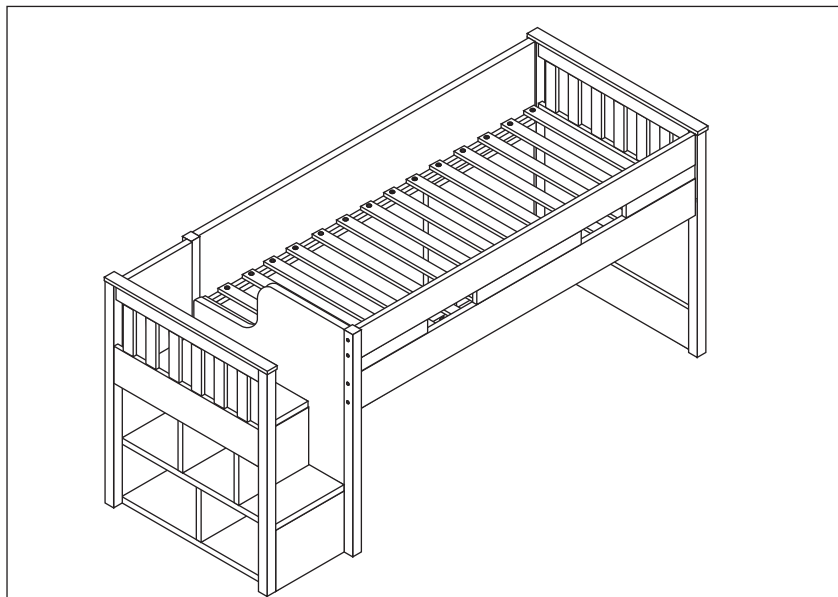

IMPORTANT - READ CAREFULLY - RETAIN FOR FUTURE REFERENCE

- A) WARNING "High beds and the upper bed of bunk beds are not suitable for children under six years due to the risk of injury from falls";
- B) WARNING "Bunk beds and high beds can present a serious risk of injury from strangulation if not used correctly. Never attach or hang items to any part of the bunk bed that are not designed to be used with the bed, for example, but not limited ropes, strings, cords, hooks, belts and bags"
- C) WARNING "Children can become trapped between the bed and the wall, a roof pitch, the ceiling, adjoining pieces of furniture (e.g. cupboards) and the like. To avoid risk of serious injury the distance between the top safety barrier and the adjoining structure shall not exceed 75 mm or shall be more than 230 mm";
- D) WARNING "Do not use the bunk bed/high bed if any structural part is broken or missing;
- E) always follow the manufacturer's instructions;
- F) the recommended size of the mattress(es); This bunk bed is suitable for a single mattress or foam bed 920mm x 1870mm. Thickness of mattress should not exceed 200mm.
- G) ventilation of the room is necessary in order to keep the humidity low and to prevent mould in and around the bed;
- H) all bunk beds and high beds intended to be assembled by other than the manufacturer or his/her representative shall include assembly instructions including a list of the parts supplied and details of any tools required to assemble the bed;
- I) This Bunk Bed Conforms to BS EN 747-1:2012+A1:2015

Tools Required For Assembly



Tools Not Use

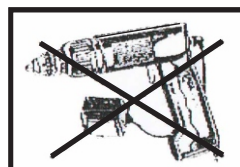

DO NOT USE POWER TOOLS TO ASSEMBLE THIS PRODUCT. USE OF POWER TOOLS WILL INVALIDATE ANY CLAIM AND MAY DAMAGE THIS PRODUCT MAKING IT UNSAFE.



DO NOT USE HAMMER

PARTS LIST

Model: CK 6216

Carton 1 of 3			Carton 3 of 3		
No.	Part Name	Pcs			
			(34)	BOTTOM PANEL (LADDER)	1
(35)	CENTER PANEL (LADDER)	1	(37)	1 ST LADDER STEP	1
(36)	FRONT PANEL LADDER	1	(39)	END LADDER STEP	1
(38)	SUPPORT PANEL (FRONT LADDER)	2	(40)	BACK PANEL (LADDER)	1
(45)	BACK SIDE PANEL	1	(42)	LEFT END PANEL (CENTER)	1
(46)	FRONT SIDE PANEL	1	(50)	RIGHT END PANEL (CENTER LOWER)	1
(54)	RIGHT PANEL (TOP)	1	(51)	RIGHT END PANEL (CENTER UPPER)	1
(58)	LEFT PANEL TOP)	1	(55)	LEFT END PANEL (CENTER UPPER)	1
(59)	SIDE RAIL	2			
	Carton 2 of 3				
(41)	LEFT END PANEL (BACK)	1			
(44)	LEFT END PANEL (FRONT)	1			
(52)	RIGHT END PANEL (BACK)	1			
(53)	RIGHT END PANEL (FRONT)	1			
(56)	LADDER SIDE BACK	1			
(57)	LADDER SIDE FRONT	1			
(60)	LVL BASE	16			
	FITTING LIST				

PARTS LIST



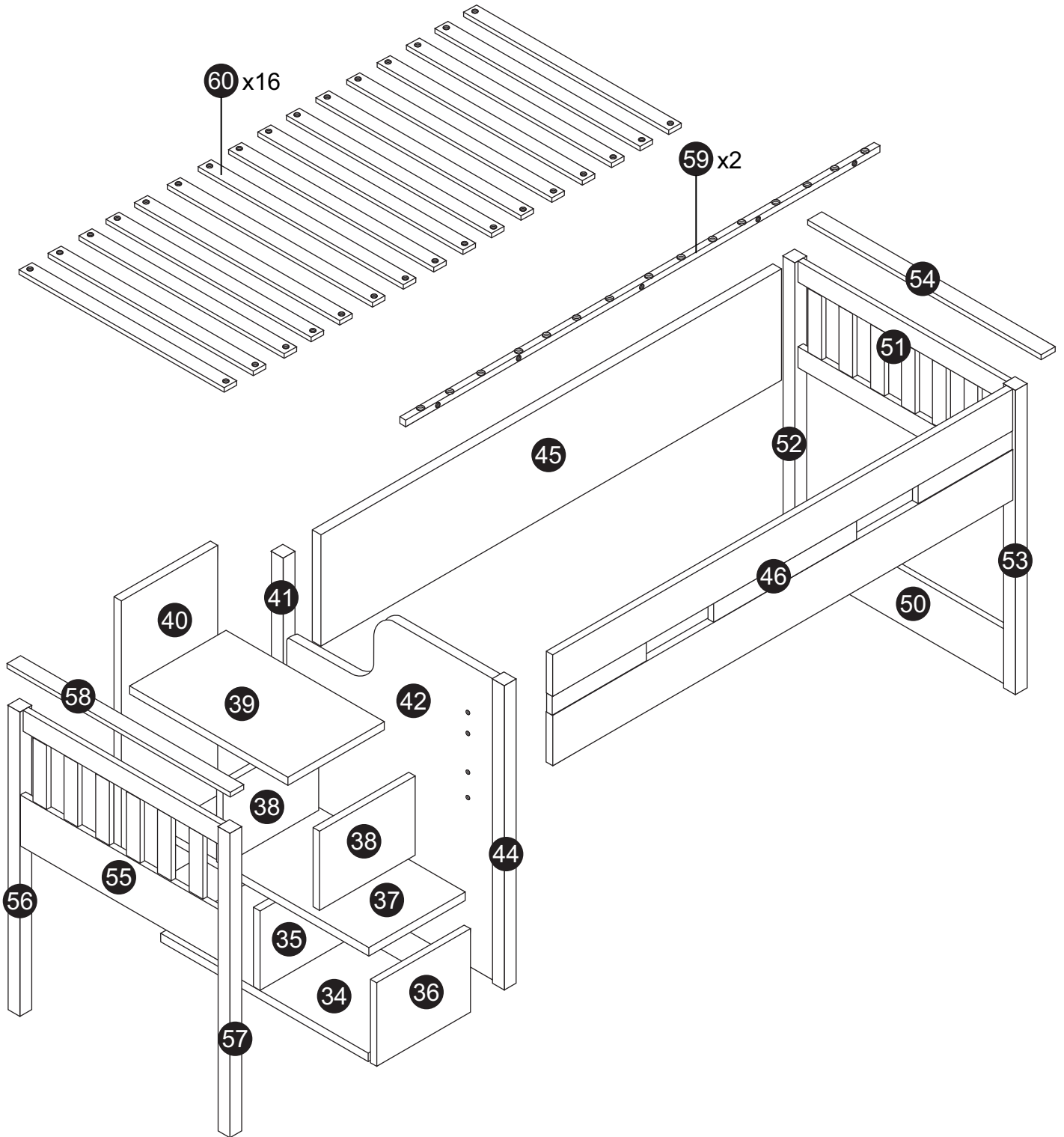







Model: CK 6216

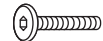

FITTING LIST

Model: CK 6216

Fitting List

No.	Part Name	Pcs
(A)	Cam 	46
(B)	Cam Stud (5137) 	46
(C)	M8 x 25mm Wood Dowel 	71
(E)	45mm Chipboard Screw 	10
(F)	M6 x 30mm Allen Bolt 	32
(G)	M6 x 35mm Allen Bolt 	10
(J)	M6 x 90mm Allen Bolt 	12
(K)	M6 x 13mm Baller 	13
(L)	M6 JCN Nut 	6
(M)	5/8 PVC Feet Nail 	2
(P)	M6 Allen Wrench 	2
(Q)	M6 x 50mm Allen Bolt 	1

CAUTION

There are many small components used in the construction of this unit. These loose items should be kept away from young children whilst assembling your unit. As an extra precaution, screw cover caps should be permanently fixed in position. (Where applicable)

USEFUL HINTS & TIPS

Two people will be required to assemble this unit

Please keep this assembly instruction for future reference

GUIDE TO ASSEMBLY





Model: CK 6216

STEP 1

WHEN FITTING CAMS
ENSURE STARTING POSITION IS CORRECT
BEFORE YOU INSERT CONNECTING BOLT
TURN CLOCKWISE UNTIL SECURE

↑
CORRECT

WRONG

 C x 42	 B x 10	 A x 25
	 K x 1	 M x 2

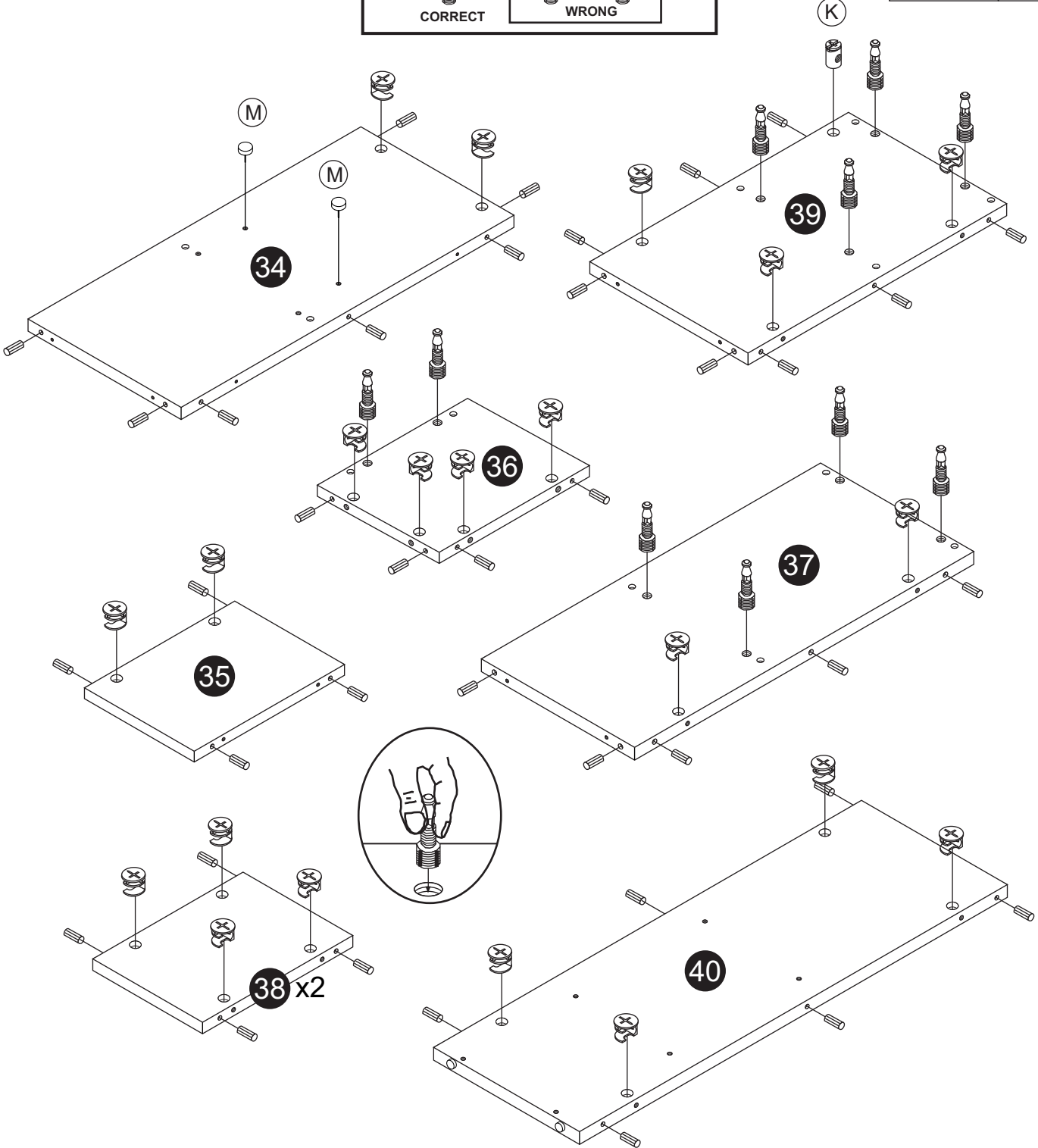

GUIDE TO ASSEMBLY

Model: CK 6216

STEP 2

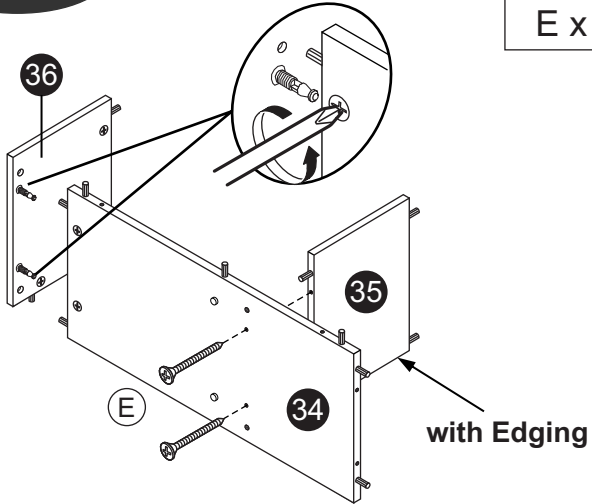

STEP 3

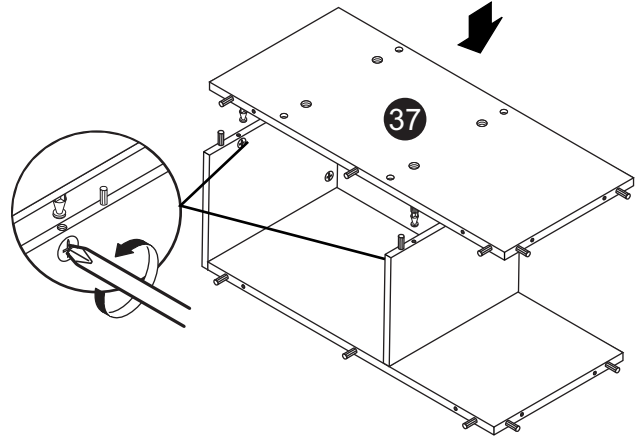

STEP 4

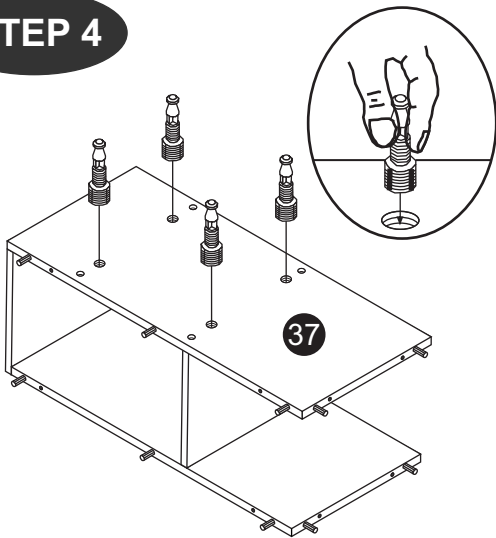

STEP 5

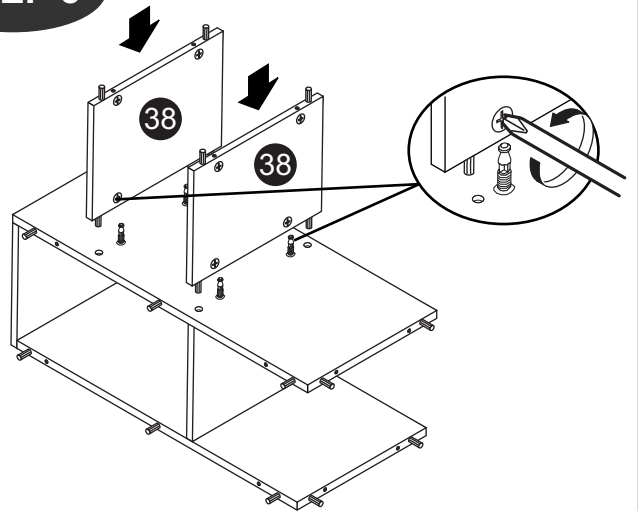

STEP 6

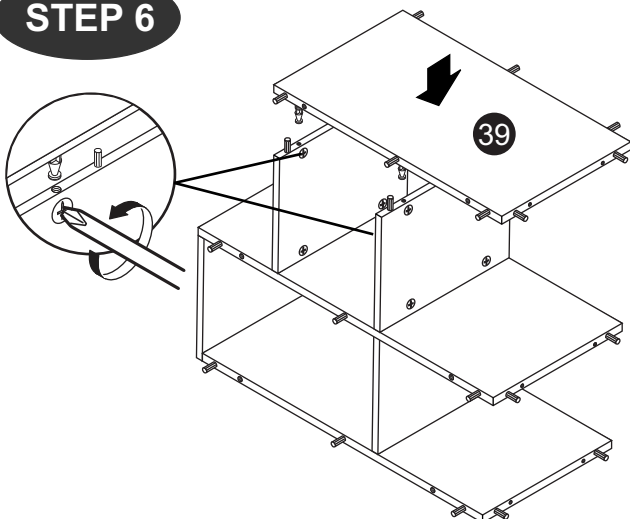

STEP 7

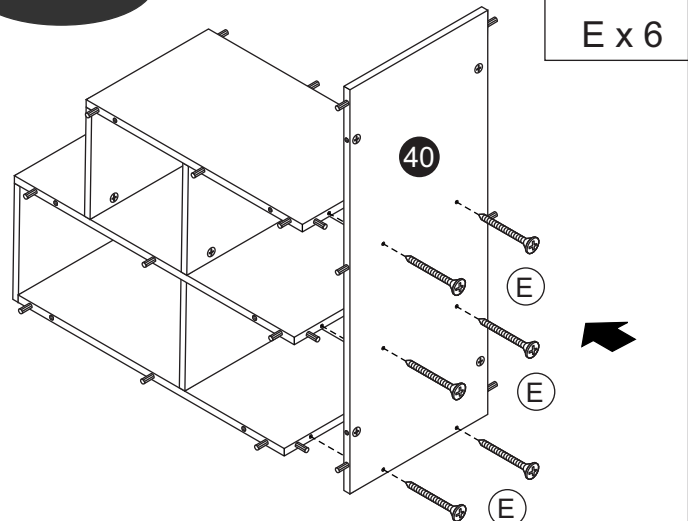

GUIDE TO ASSEMBLY

Model: CK 6216

STEP 8

B x 19

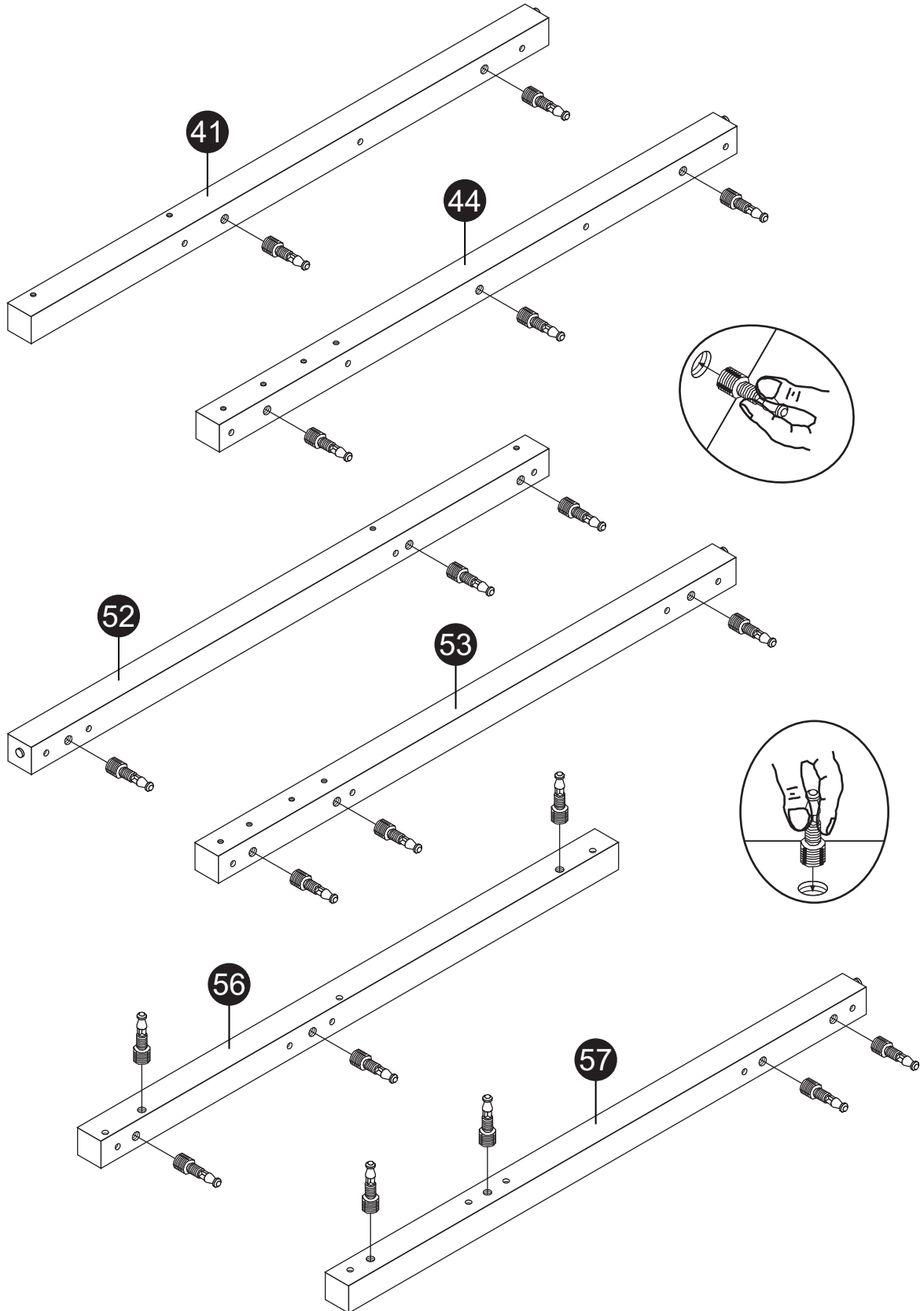



GUIDE TO ASSEMBLY

Model: CK 6216

STEP 9

WHEN FITTING CAMS
ENSURE STARTING POSITION IS CORRECT
BEFORE YOU INSERT CONNECTING BOLT
TURN CLOCKWISE UNTIL SECURE

✓ CORRECT ✗ WRONG

 A x 19	 B x 1
	 C x 25

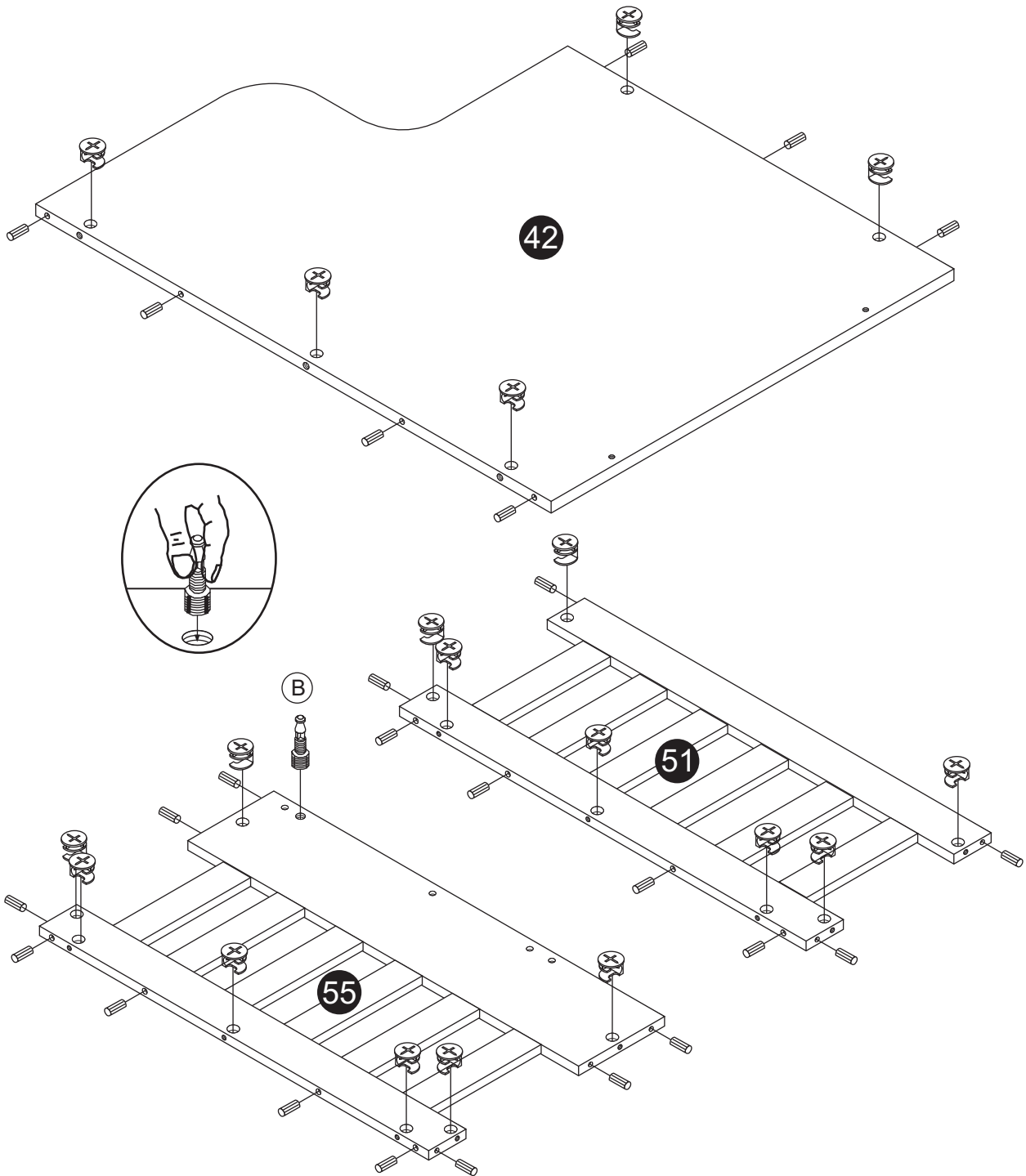

GUIDE TO ASSEMBLY

Model: CK 6216

STEP 10

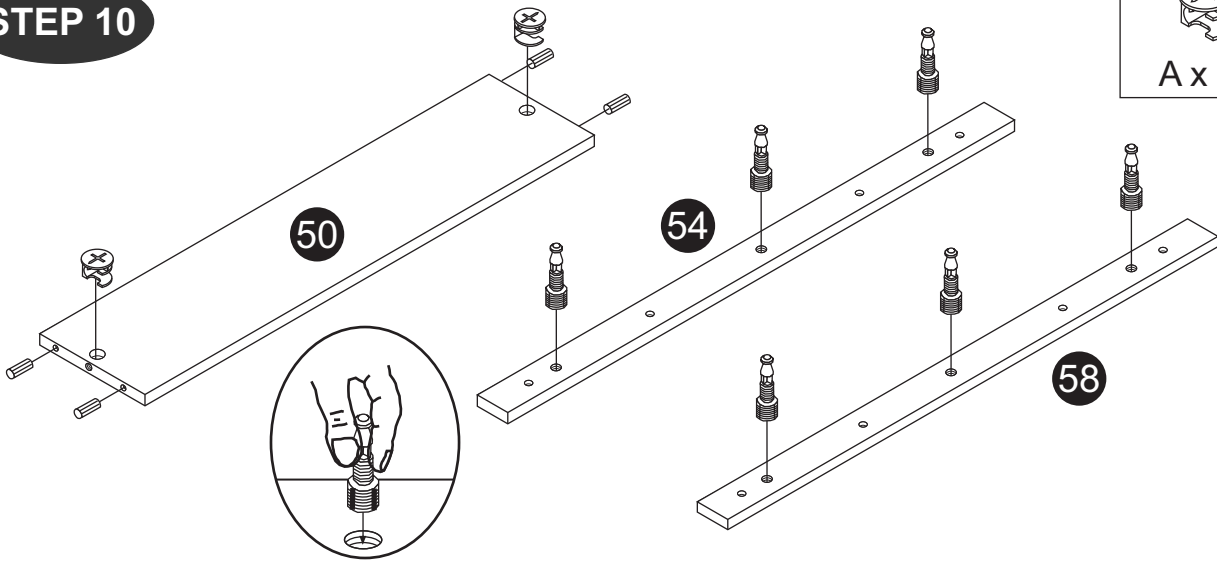

STEP 11

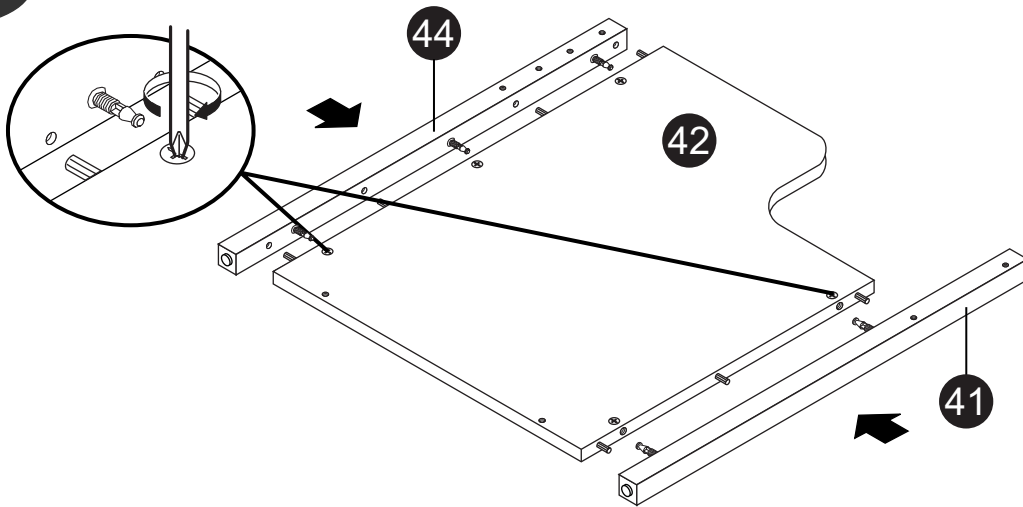

STEP 12

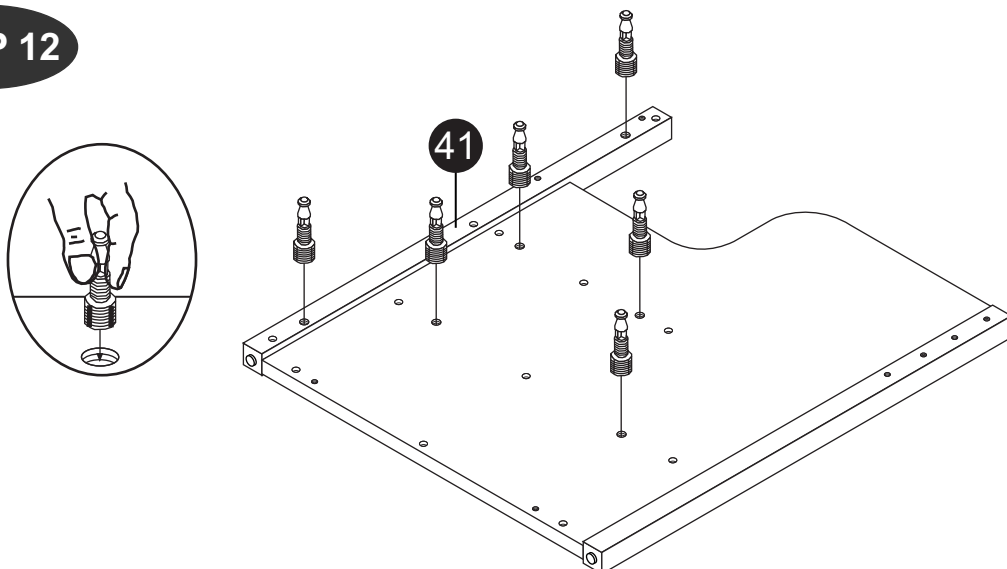

B x 6

GUIDE TO ASSEMBLY

10
14

Model:

CK 6216

STEP 13

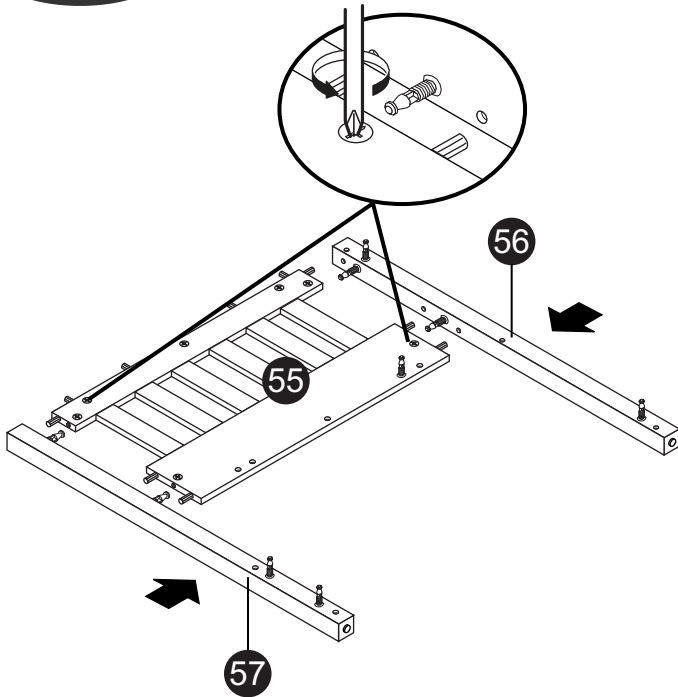

STEP 14

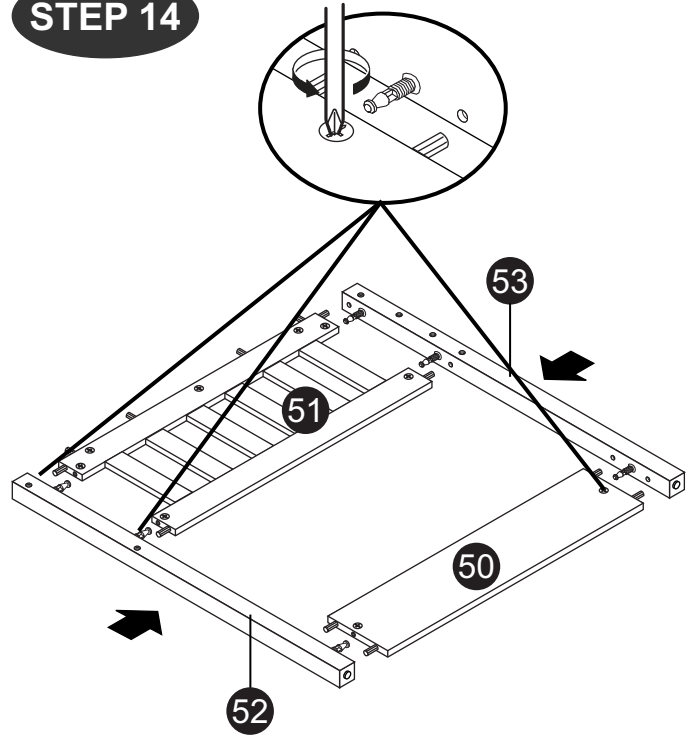

STEP 15

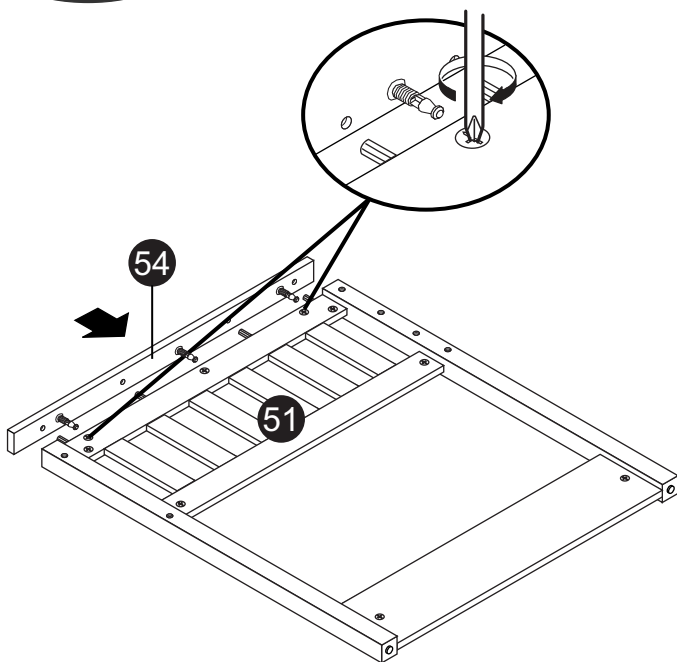

STEP 16

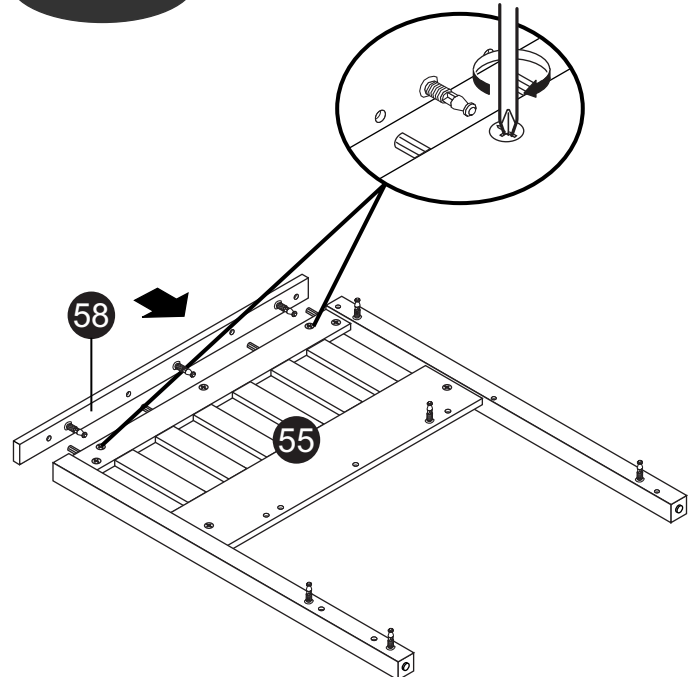

GUIDE TO ASSEMBLY

11
14

Model: CK 6216

STEP 17

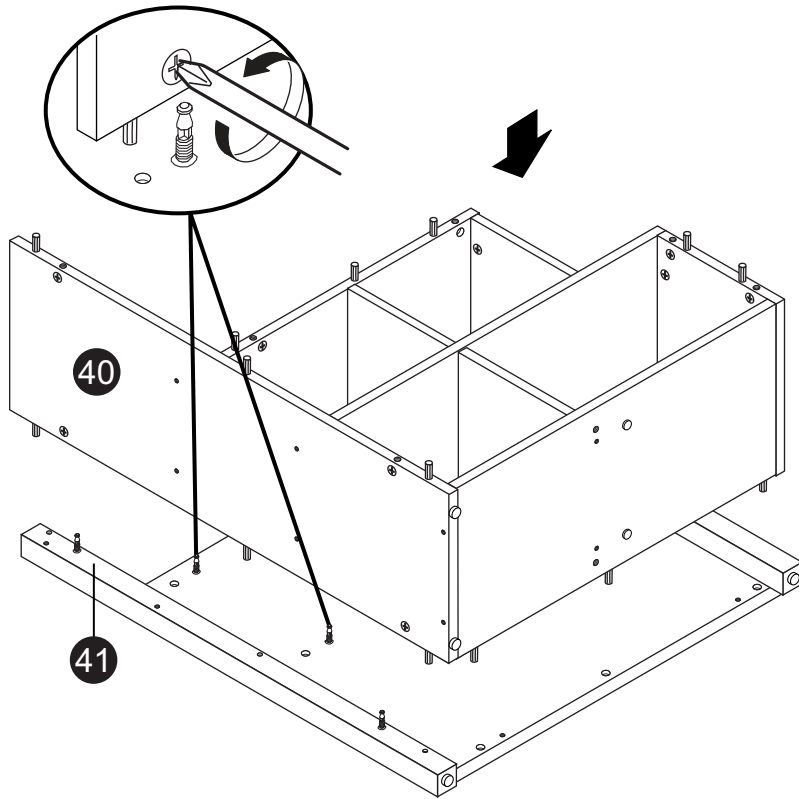

STEP 18

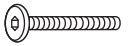
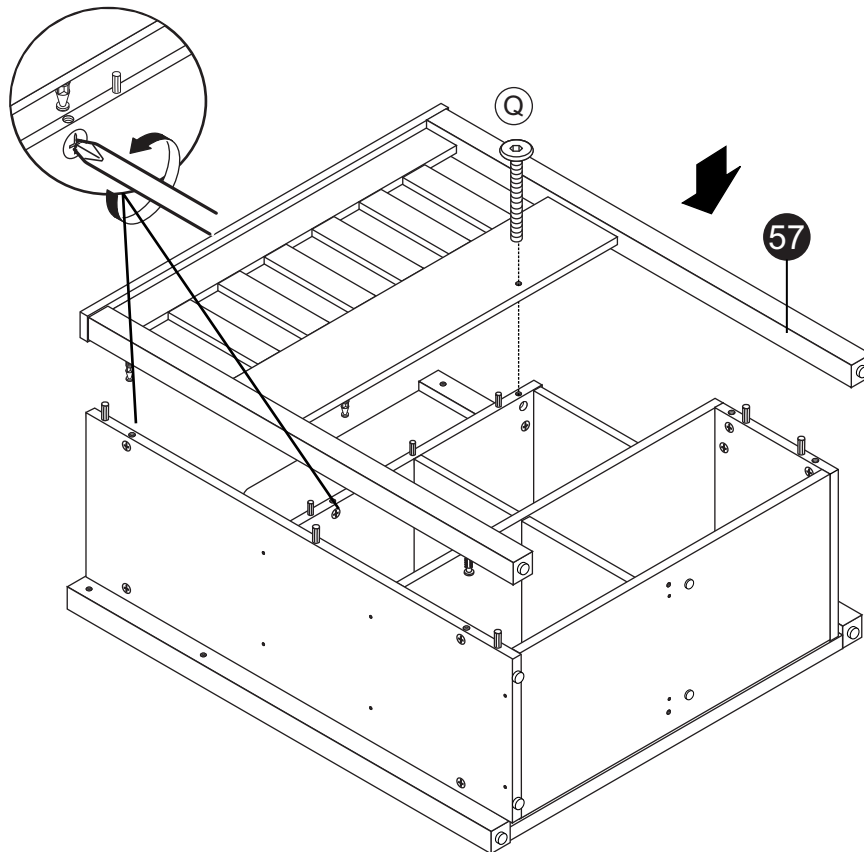

Q x 1

GUIDE TO ASSEMBLY

12
14

Model: CK 6216

STEP 19

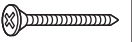

E x 2

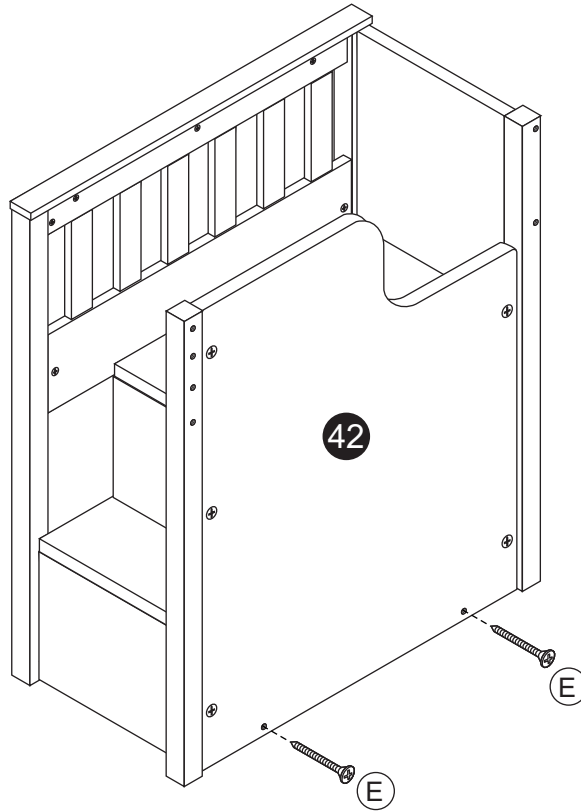

STEP 20



K x 12

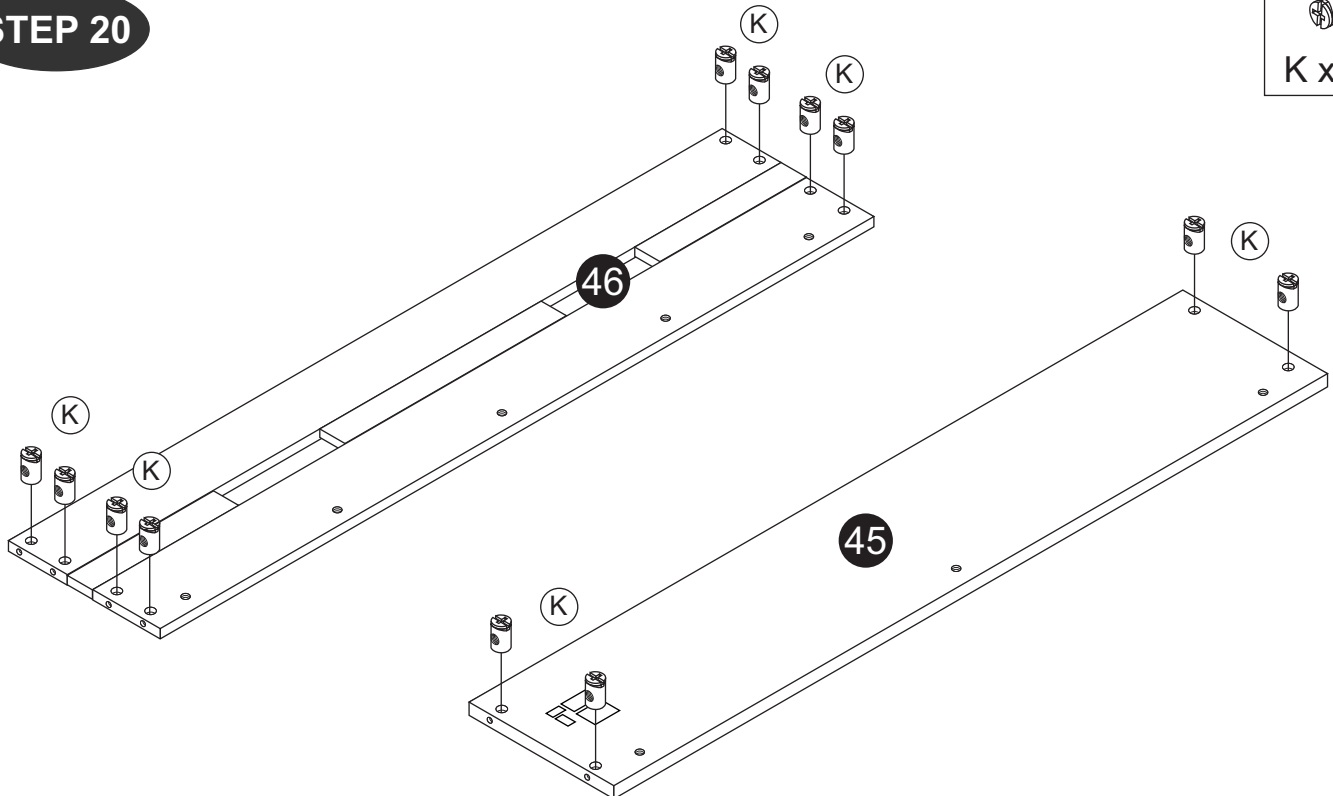

GUIDE TO ASSEMBLY

13
14

Model: CK 6216

STEP 21

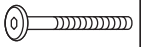
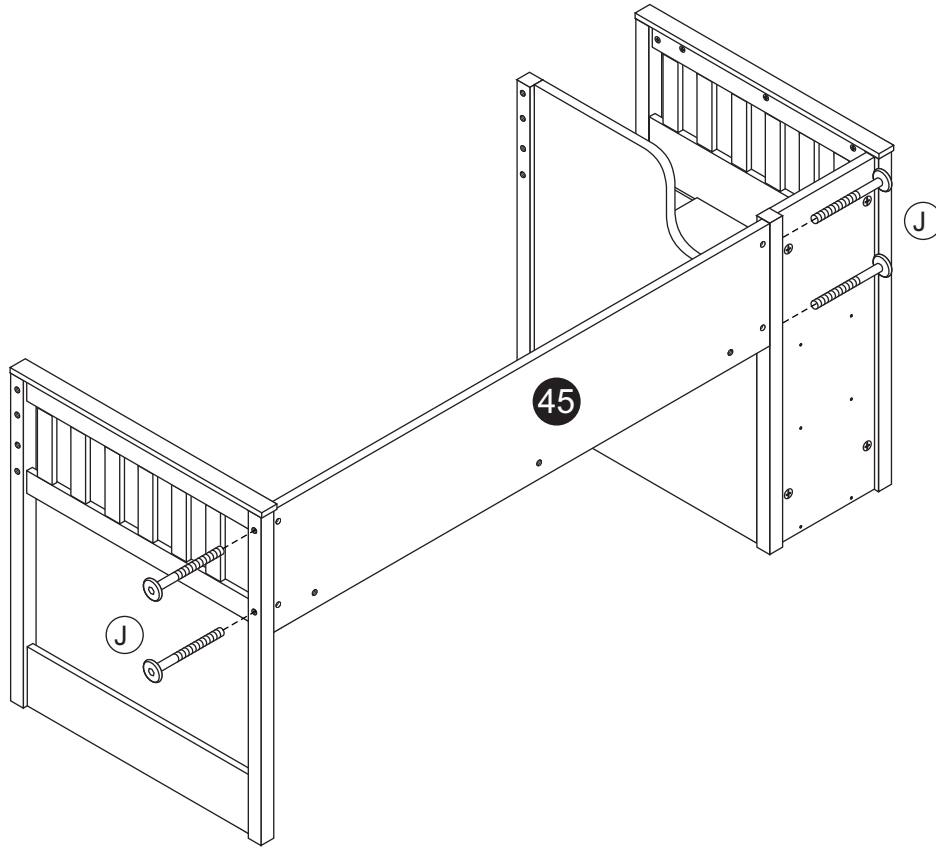

J x 4

STEP 22

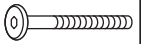
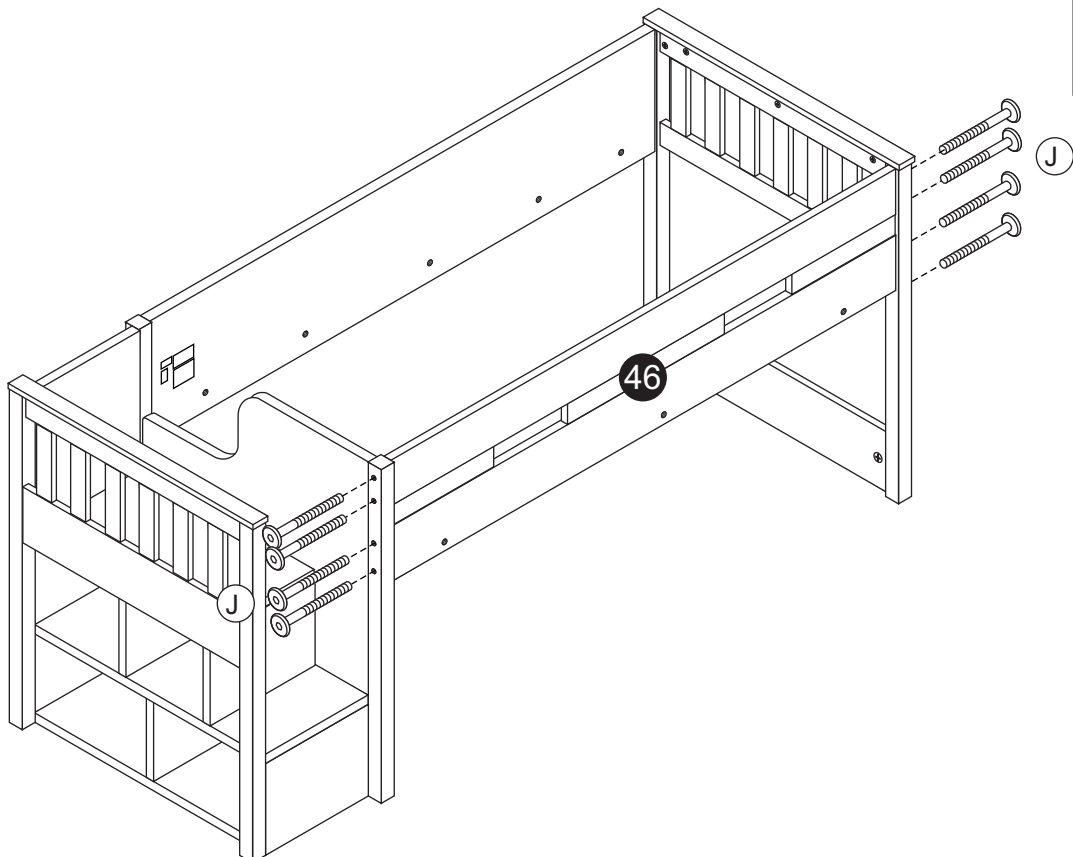

J x 8

GUIDE TO ASSEMBLY

14
14

Model: CK 6216

STEP 23

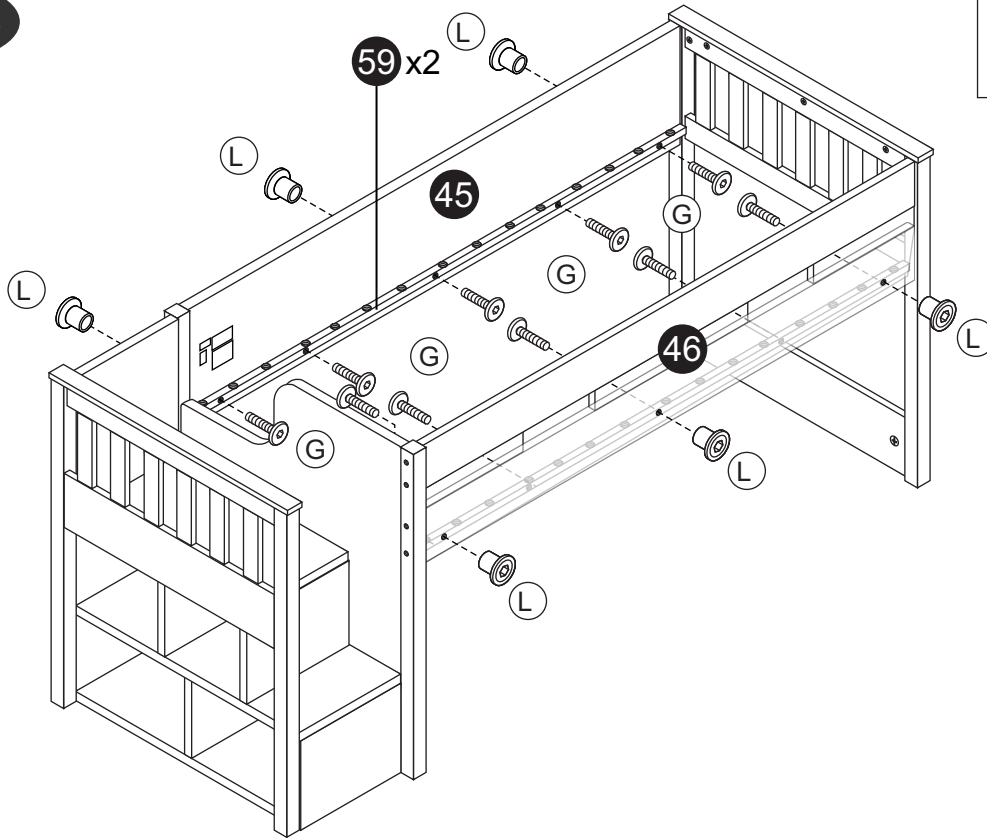

L x 6



G x 10

STEP 24

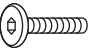
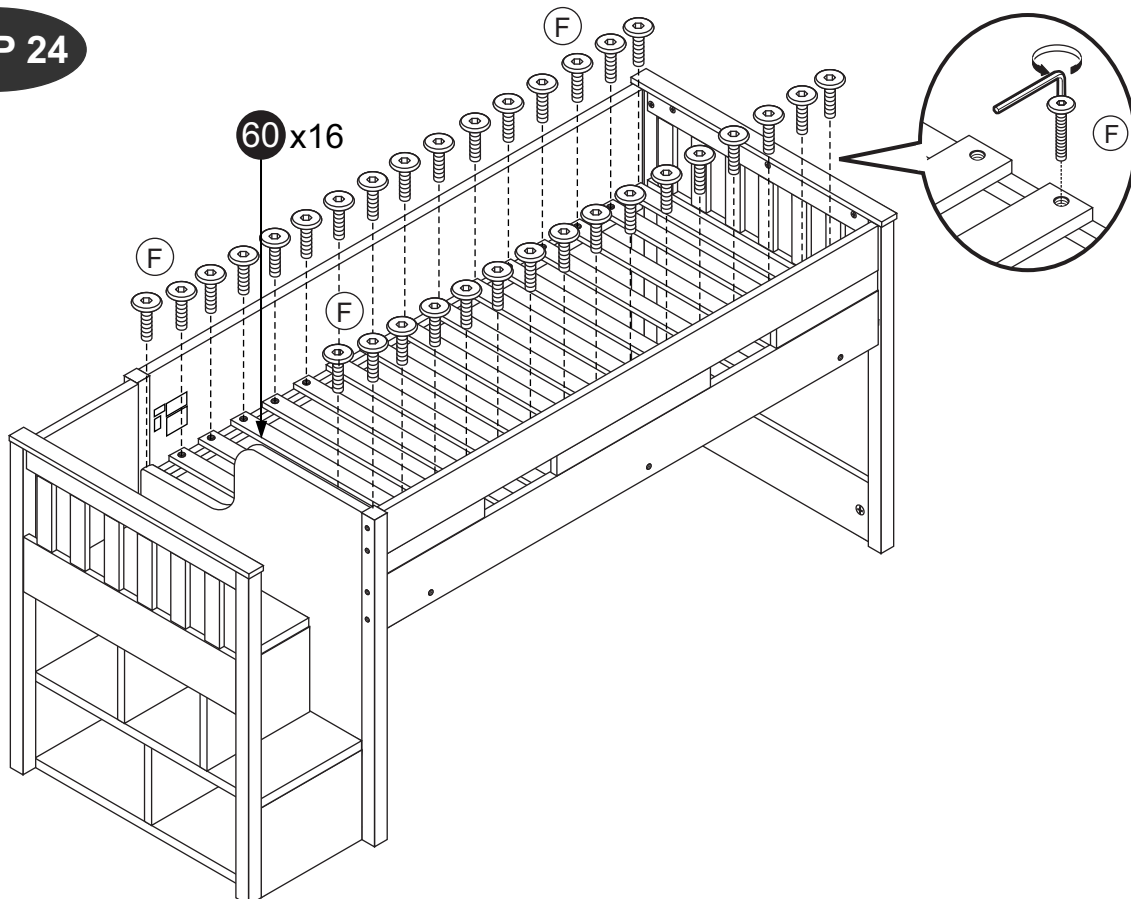

F x 32

ASSEMBLY INSTRUCTIONS

1
6

MODEL : CK 6233

PRODUCT SIZE : 900mm(L) x 596mm(W) x 700mm(H)

Thank you for purchasing this product. Before starting assembly we suggest you spend a short time reading through this leaflet, then follow the simple step by step guide.
Two persons are needed to assemble this product.



* Approximately 1 Hours



* 2 People Required

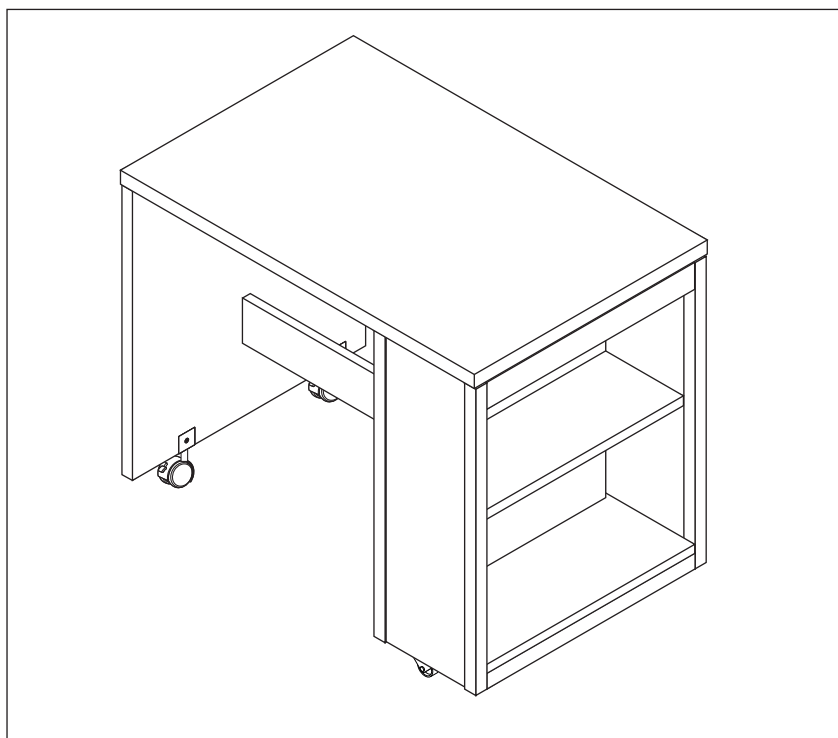

Ensure that you check regularly that all bolt are securely fastened and all components are in place.

If spare parts are required, contact your dealer. Do not use substitute part.

This instructions should be kept in a safe place for future reference.

Tools Required For Assembly



Tools Not Use

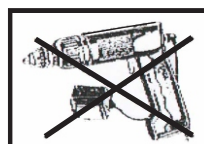

DO NOT USE POWER TOOLS TO ASSEMBLE THIS PRODUCT. USE OF POWER TOOLS WILL INVALIDATE ANY CLAIM AND MAY DAMAGE THIS PRODUCT MAKING IT UNSAFE.



DO NOT USE HAMMER

PARTS LIST

2 6

Model: CK 6233

Carton 1 of 1			Hardware		
No.	Part Name	Pcs	No.	Part Name	Pcs
⑳	PLINTH PANEL (DESK)	1	Ⓐ	Cam	28
㉑	BOTTOM PANEL (DESK)	1	Ⓑ	Cam Stud (5137)	28
㉒	CENTER PANEL (DESK)	1	Ⓒ	M8 x 25mm Wood Dowel	48
㉓	RIGHT PANEL (DESK)	1	Ⓓ	15mm Chipboard Screw	4
㉔	RIGHT POST BACK (DESK)	1	Ⓔ	M6 x 25mm Allen Bolt	2
㉕	RIGHT POST FRONT (DESK)	1	Ⓕ	40mm Plate Nylon Caster	2
㉖	BACK PANEL (DESK)	1	Ⓖ	16.5mm U Shape PP Caster	2
㉗	FRONT PANEL (DESK)	1	Ⓗ	M6 Cap Nut	2
㉘	LEFT PANEL (DESK)	1	Ⓙ	Spanar	1
㉙	LEFT POST BACK (DESK)	1	Ⓚ	M6 Allen Wrench	1
㉚	LEFT POST FRONT (DESK)	1			
㉛	CENTER SUPPORT PANEL (DESK)	1			
㉜	BACK PANEL (DESK)	1			
㉝	TOP PANEL (DESK)	1			
FITTING LIST					

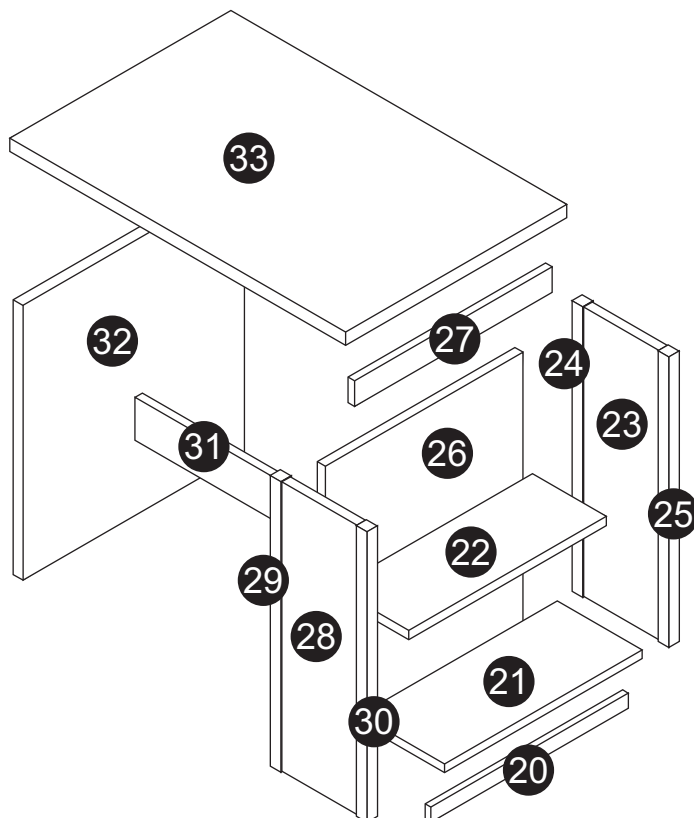

CAUTION
 There are many small components used in the construction of this unit. These loose items should be kept away from young children whilst assembling your unit. As an extra precaution, screw cover caps should be permanently fixed in position. (Where applicable)

USEFUL HINTS & TIPS
 Two people will be required to assemble this unit
 Please keep this assembly instruction for future reference

GUIDE TO ASSEMBLY

3
6

Model: CK 6233

STEP 1

WHEN FITTING CAMS

ENSURE STARTING POSITION IS CORRECT
BEFORE YOU INSERT CONNECTING BOLT
TURN CLOCKWISE UNTIL SECURE

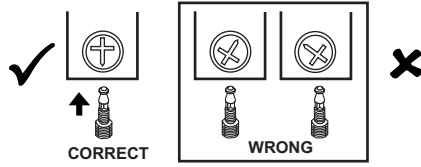

B x 5



A x 26



C x 45

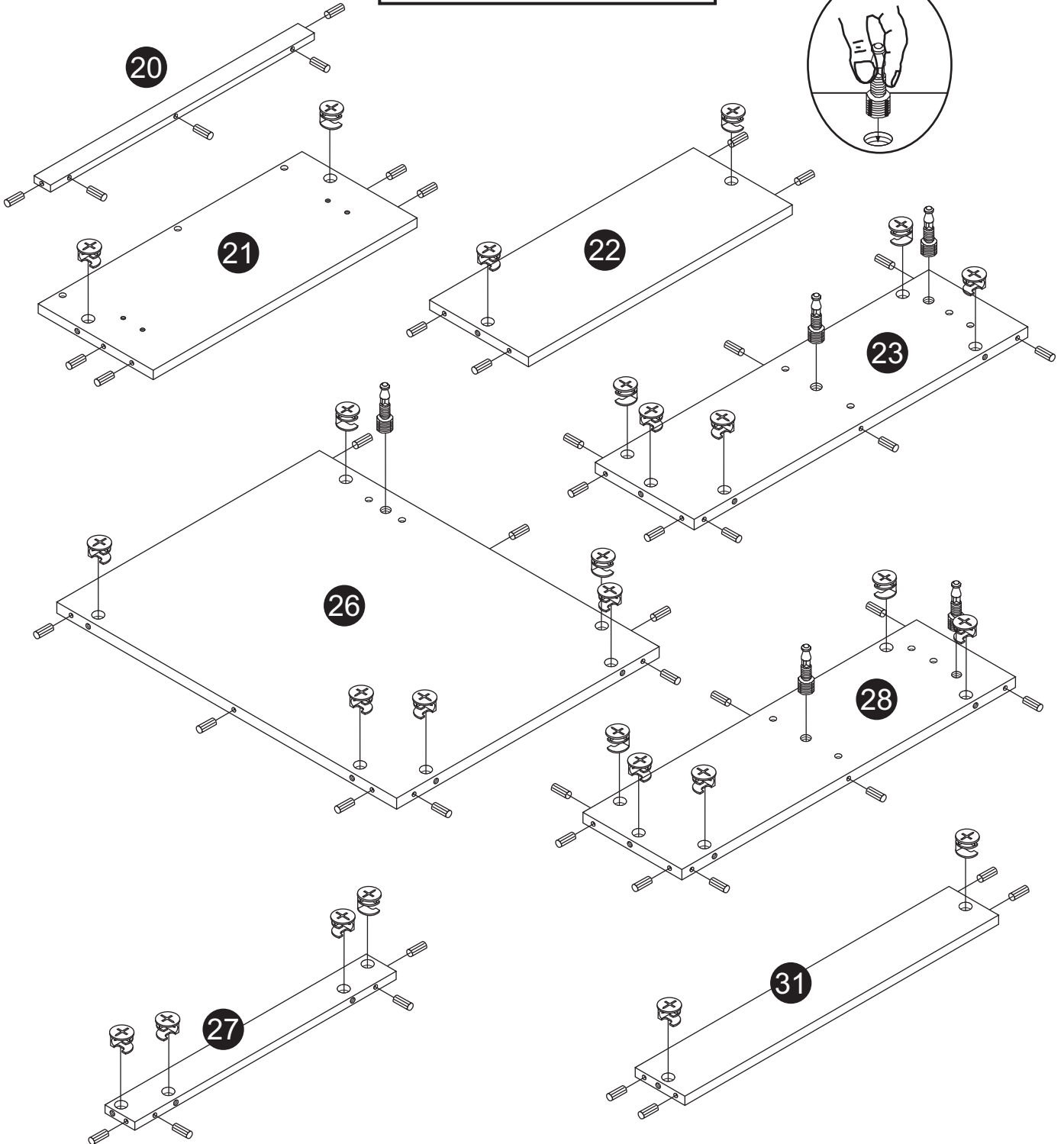
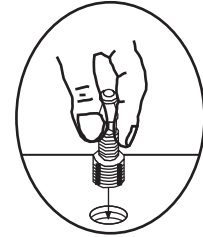

GUIDE TO ASSEMBLY

4
6

Model: CK 6233

STEP 2

WHEN FITTING CAMS

ENSURE STARTING POSITION IS CORRECT
BEFORE YOU INSERT CONNECTING BOLT
TURN CLOCKWISE UNTIL SECURE

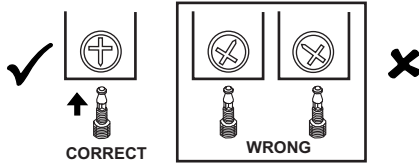

B x 23



A x 2



C x 3

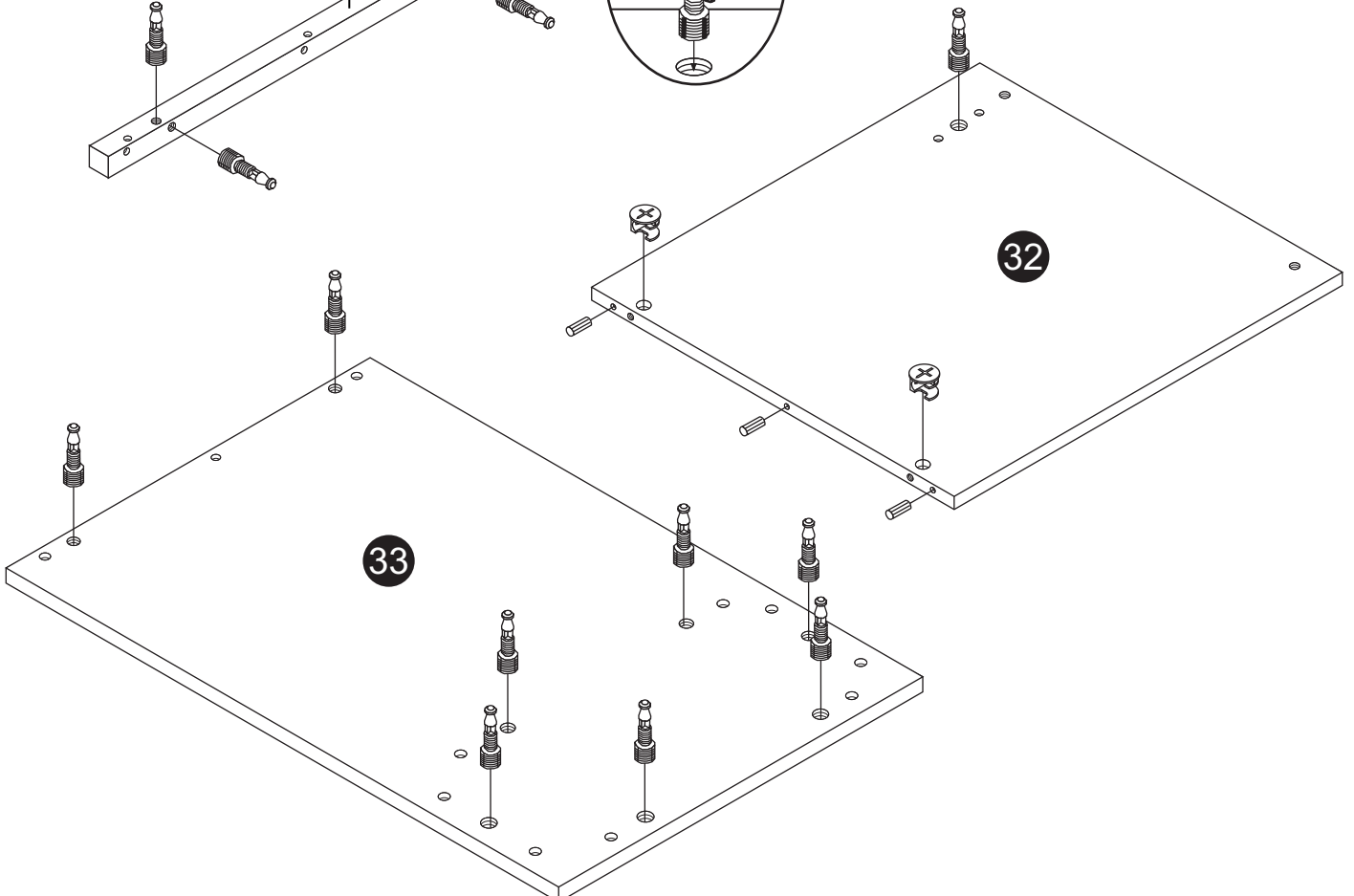
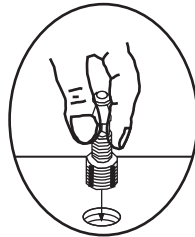
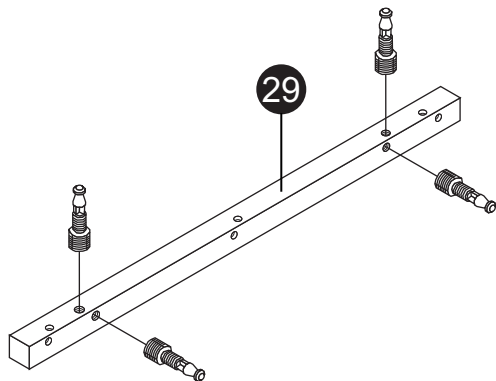
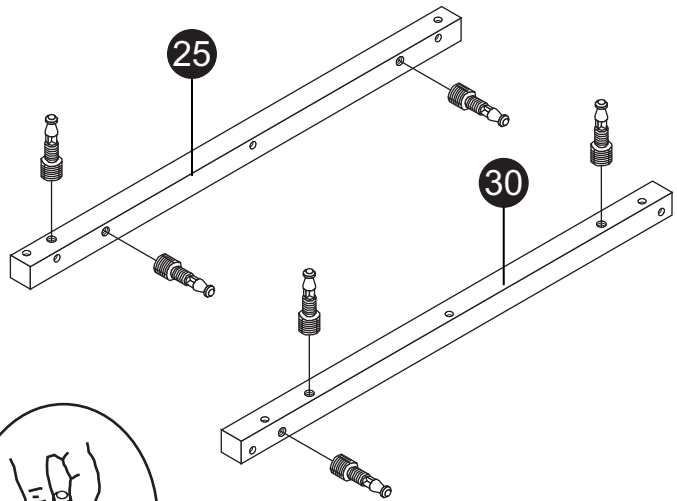
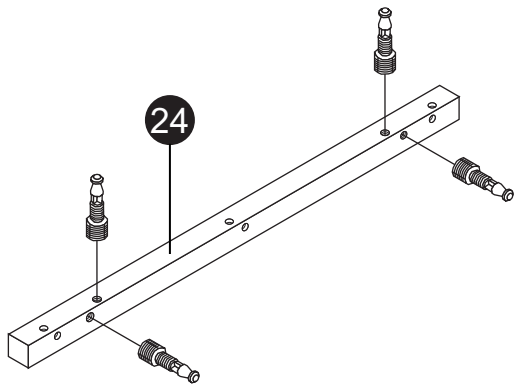

GUIDE TO ASSEMBLY

5
6

Model:

CK 6233

STEP 3



D x 4



F x 2

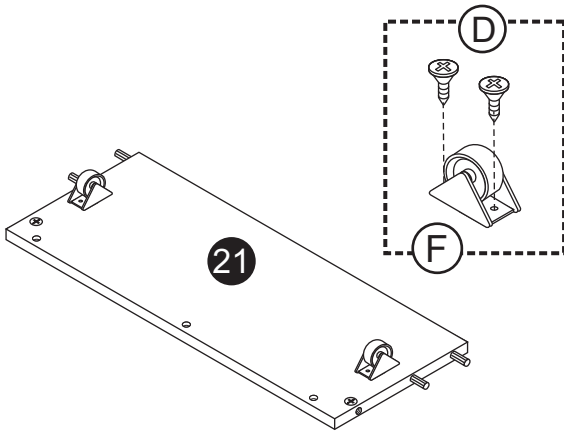

STEP 4

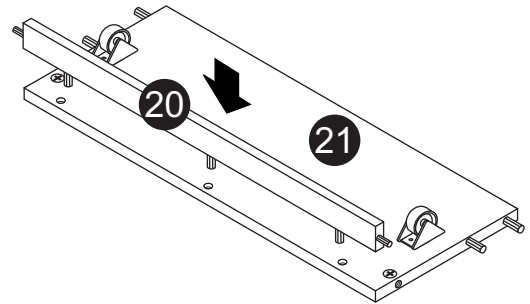

STEP 5

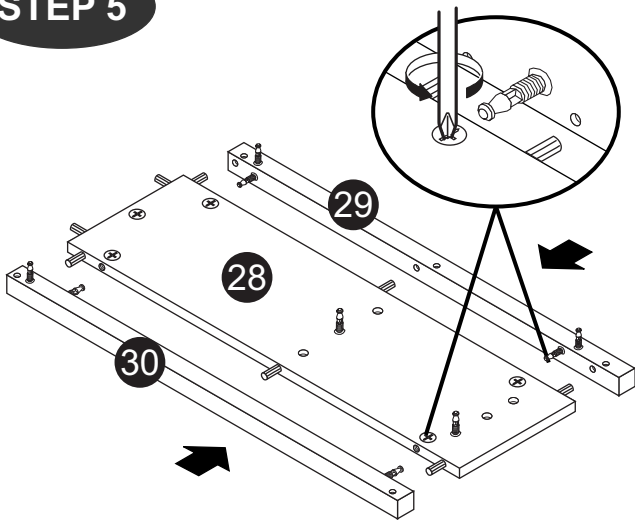

STEP 6

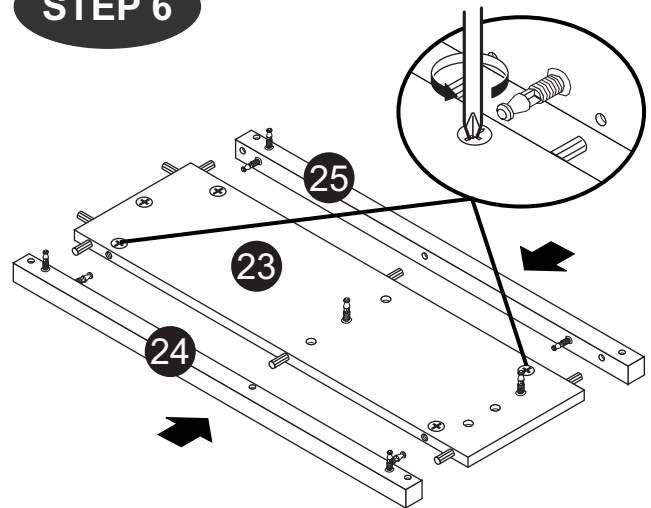

STEP 7

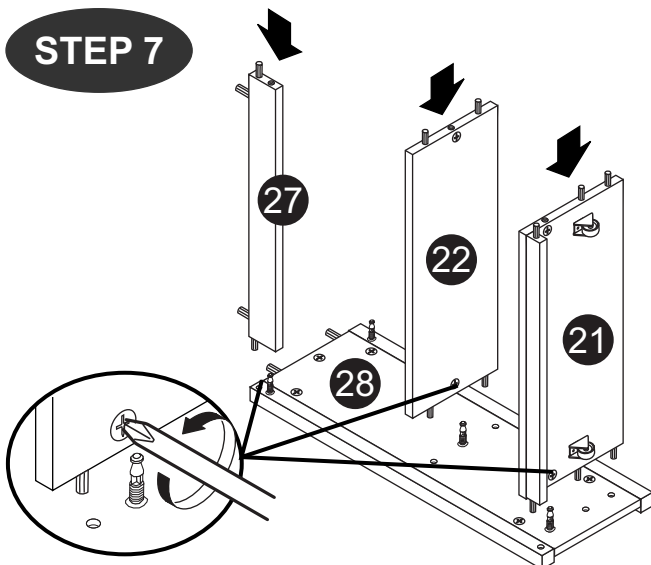

STEP 8

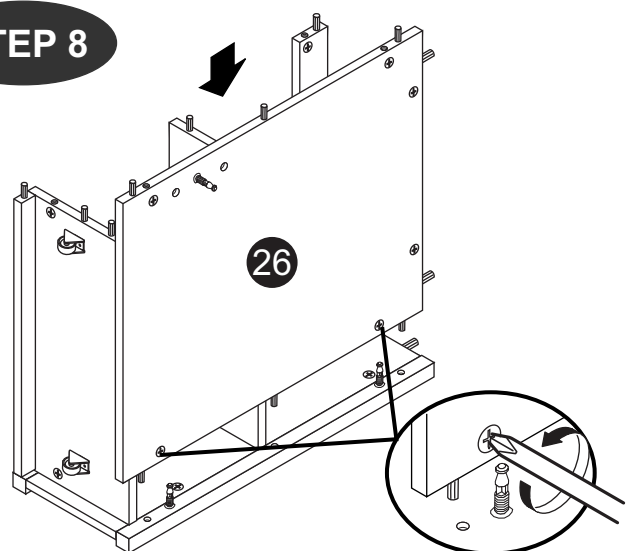

GUIDE TO ASSEMBLY

Model:

CK 6233

STEP 9

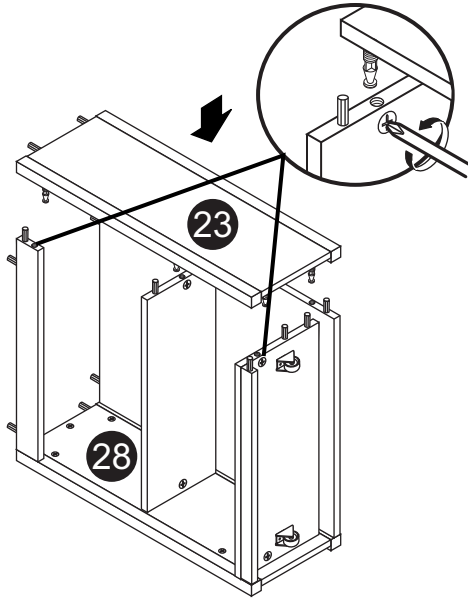

STEP 10

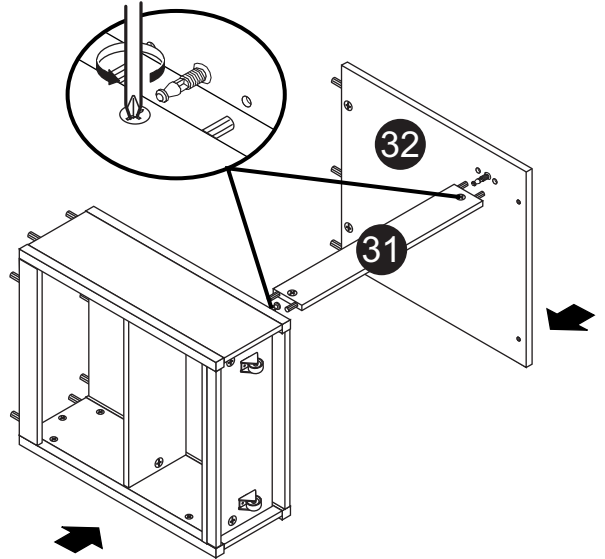

STEP 11



E x 2



G x 2



H x 2

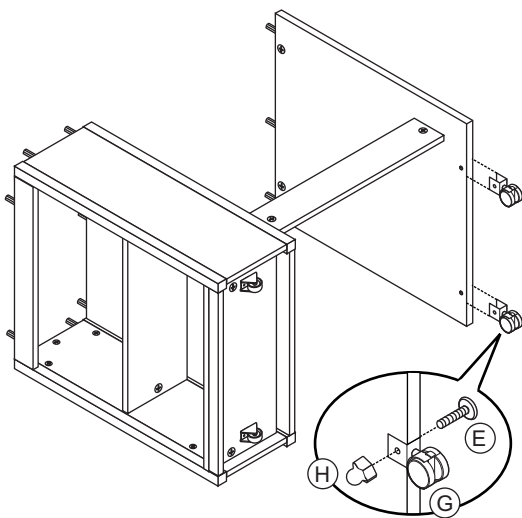

STEP 12

