

SAFETY ADVICE

Please take the time to carefully read through the whole of these instructions before you commence.

Keep these instructions for future reference.

Unpack, inspect and check of all of the contents.

Please dispose of all packing safely.

Small components parts could choke a child is swallowed.

We strongly recommend that you keep children well away from the work area.

It would be sensible to lay a sheet or blanket on the floor where you intend to work to avoid

Scratching this product and protect your floor.

This product is heavy. Take extreme care when lifting to avoid personal injury or damage to the product.

This bed is heavy. Always lift this bed with two people.

Assemble the product as close to its intended final position in the room as possible.

Keep any sharp object away from the bed frame.

HANDY HINT: If you keep the hardware in a bowl during assembly you will be less likely to lose them.

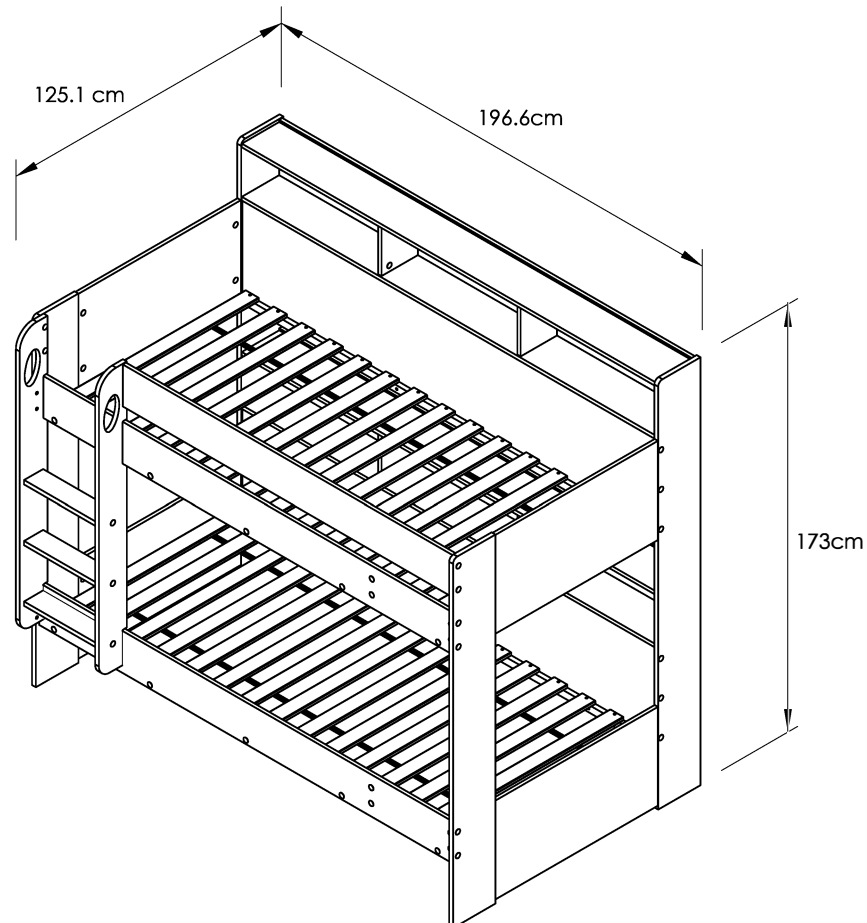

All Dimensions are approximates.

BS EN 747-1:2012+A1:2015 SAFETY WARNINGS AND GENERAL NOTES: IMPORTANT - READ CAREFULLY - RETAIN FOR FUTURE REFERENCE

WARNING - High beds and the upper bed of bunk beds are not suitable for children under six years due to the risk of injury from falls.

WARNING - Bunk beds and high beds can present a serious risk of injury from strangulation if not used correctly. Never attach or hang items to any part of the bunk bed that are not designed to be used with the bed, for example, but not limited to ropes, strings, cords, hooks, belts and bags.

WARNING - Children can become trapped between the bed and the wall, a roof pitch, the ceiling, adjoining pieces of furniture (e.g. cupboards) and the like. To avoid risk of serious injury the distance between the top safety barrier and the adjoining structure shall not exceed 75mm or shall be more than 230mm.

WARNING - Do not use the bunk bed / high bed if any structural part is broken or missing.

- Always follow the manufacturer's instructions.
- Prohibit horseplay on or under the bed. Always prohibit jumping on the bed.
- Prohibit more than one person on high bed and upper bunk.
- Always use the ladder for entering and leaving the high bed and upper bunk.
- Only use a mattress that is 1905mm (75") long and 915mm (36") wide on upper and lower bunk bed.
The top of the mattress shall be at least 160mm (6-1/4") below the edge of the safety barriers.
- Ensure thickness of mattress below the mark that had been made at the entrance of upper bunk.
- Ensure that ventilation of the room is necessary in order to keep the humidity low and to prevent mould in and around the bed.
- All assembly fastenings should always be tightened properly and that care should be taken that no fittings are loose.

WARNING - Do not use any power tools as this may damage the frame and will invalid any claim.

This item conforms the European Safety Standards - BS EN 747-1:2012+A1:2015.

The top of the mattress must
not come above this line

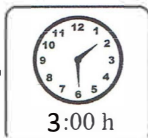
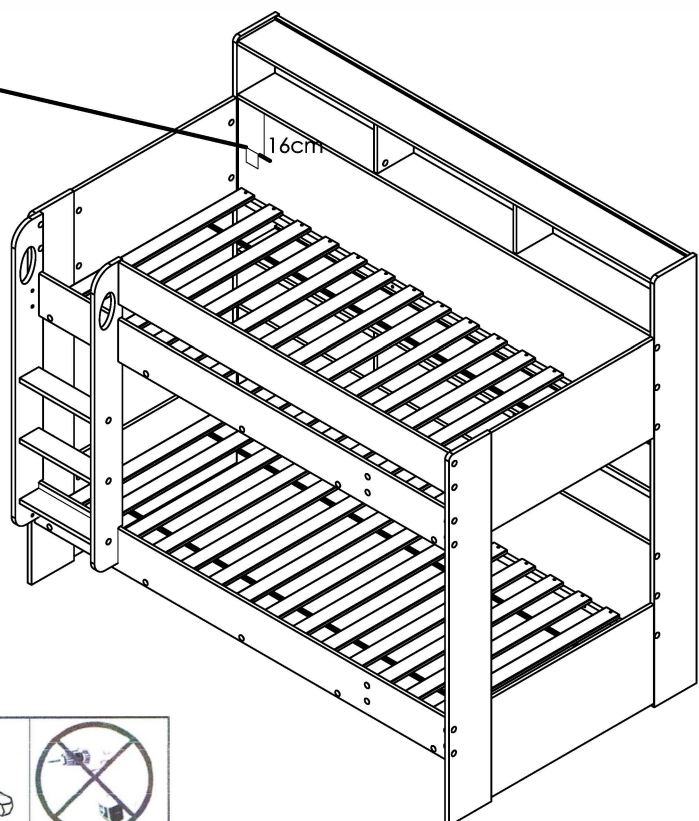

PART LIST

Model : Oliver Bunk Bed

Carton 1 of 4

No.	Part Name	Pcs
①L	HEADBOARD POST (FRONT LEFT)	1
①R	HEADBOARD POST (FRONT RIGHT)	1
②L	HEADBOARD POST (REAR LEFT)	1
②R	HEADBOARD POST (REAR RIGHT)	1
③	HEADBOARD PANEL (TOP)	2
④	HEADBOARD PANEL (BOTTOM)	2

Carton 2 of 4

④A	STOPPER	2
⑤	SIDE RAIL (FRONT)	2
⑥	SLAT SUPPORT	4
⑦	SEMI GUARD RAIL	1
⑧	FULL GUARD RAIL	2

FITTING LIST

Carton 3 of 4

⑨	TOP SHELF	2
⑩	BOTTOM SHELF	2
⑪	DIVIDER	4
⑫	BACK PANEL	2
⑬L	LADDER SIDE (LEFT)	1
⑬R	LADDER SIDE (RIGHT)	1
⑭	LADDER SLAT	3

Carton 4 of 4

⑮	SLAT	30
---	------	----

PART LIST

Model : Oliver Trundle

Carton 1 of 1

No.	Part Name	Pcs
①	FRONT PANEL	1
②	REAR PANEL	1
③	SIDE PANEL	2
④	BASE SUPPORT	2
⑤	BASE PANEL	2
	FITTING LIST	

Parts

ALL PARTS ARE LABELLED WITH NUMBER ACCORDINGLY

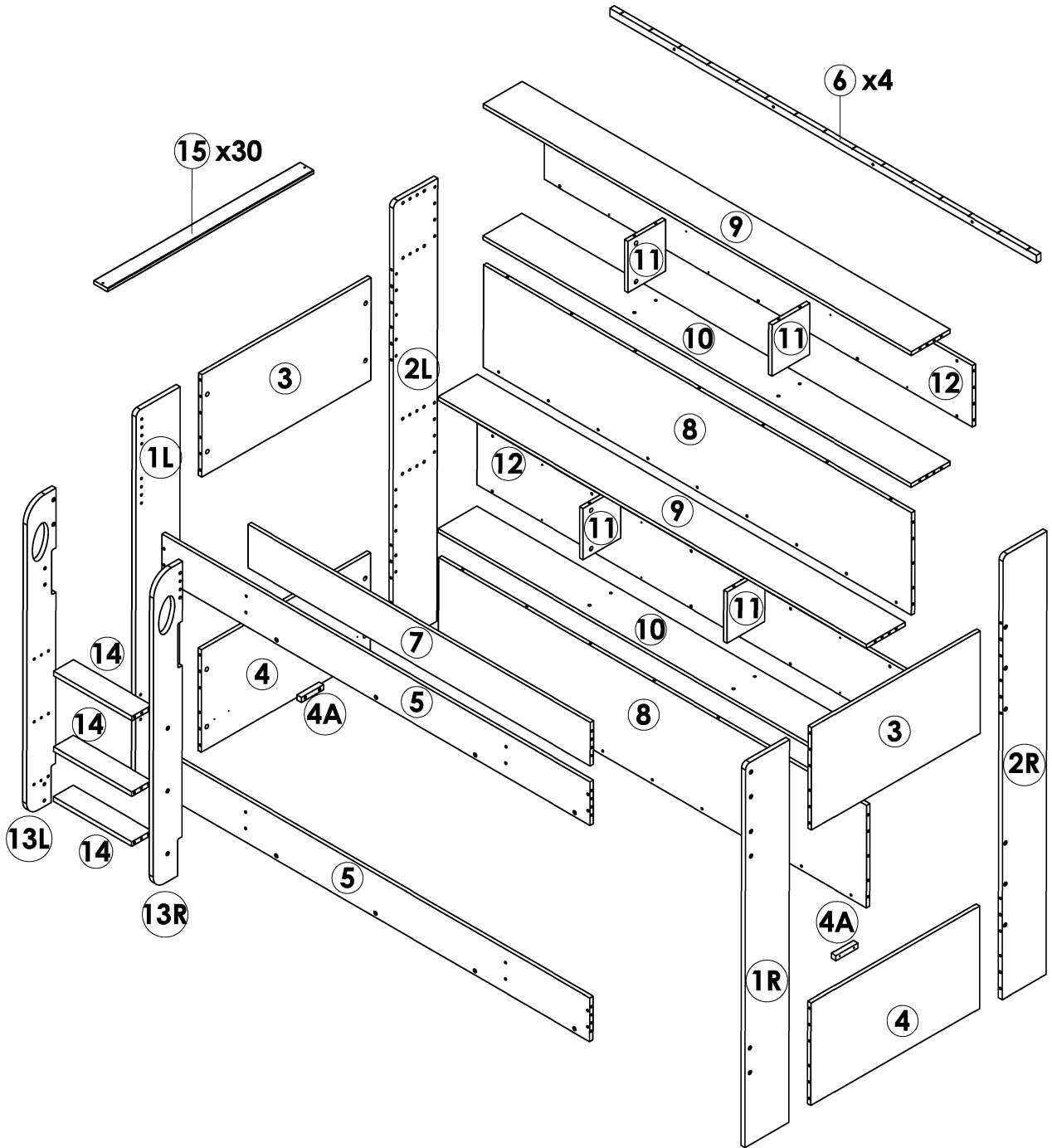

Hardware

A

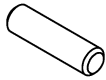

PLASTIC DOWEL (M8 x 30MM)
146 PCS

B

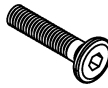

JCBC BOLT (M6 x 25MM)
2 PCS

C

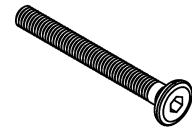

JCBC BOLT (M6 x 55MM)
38 PCS

D



JRN NUT (M6 x 13MM)
38 PCS

E



JCN NUT (M6 x 12MM)
2 PCS

F



JCBC W SCREW (M7 x 32MM)
20 PCS

G

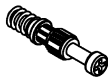

CONNECTING BOLT (24MM)
48 PCS

H



MINIFIX (12MM)
48 PCS

J



CSK C/B SCREW (M4 x 32MM)
60 PCS

K



P/H RATTAN SCREW (#8 x 25MM)
4 PCS

L



P/H RATTAN SCREW (#8 x 32MM)
20 PCS

N



ROUND STICKER (0.5 x 21MM)
76 PCS

P

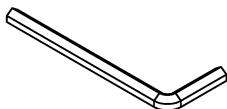

ALLEN KEY (M4 x 60MM)
2 PCS

STEP 1

Insert **(A)** into $\varnothing 8\text{MM}$ holes on **Headboard Panel (Top), Headboard Panel (Bottom), Side Rail (Front), Slat Support, Semi Guard Rail, Full Guard Rail, Top Shelf, Bottom Shelf, Divider, Back Panel and Ladder Slat.**

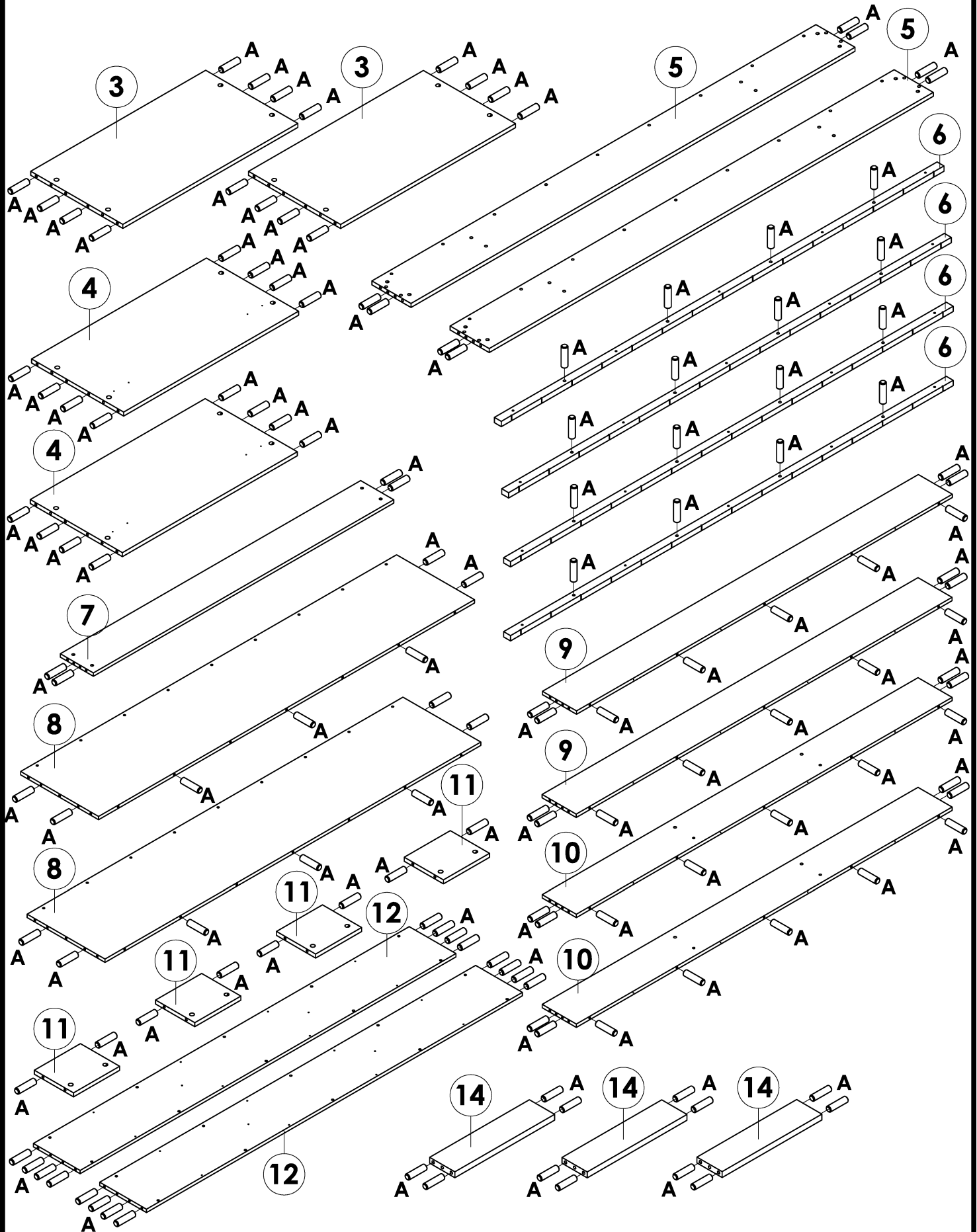

STEP 2

DO NOT use any power tools as this may damage the bed frame and will invalidate any claim.

G



24

Insert **(G)** into $\varnothing 10\text{MM}$ holes on **Headboard Post (Rear Left)**, **Headboard Post (Rear Right)**, **Top Shelf** and **Bottom Shelf**, tighten it up by using crosshead screw driver.

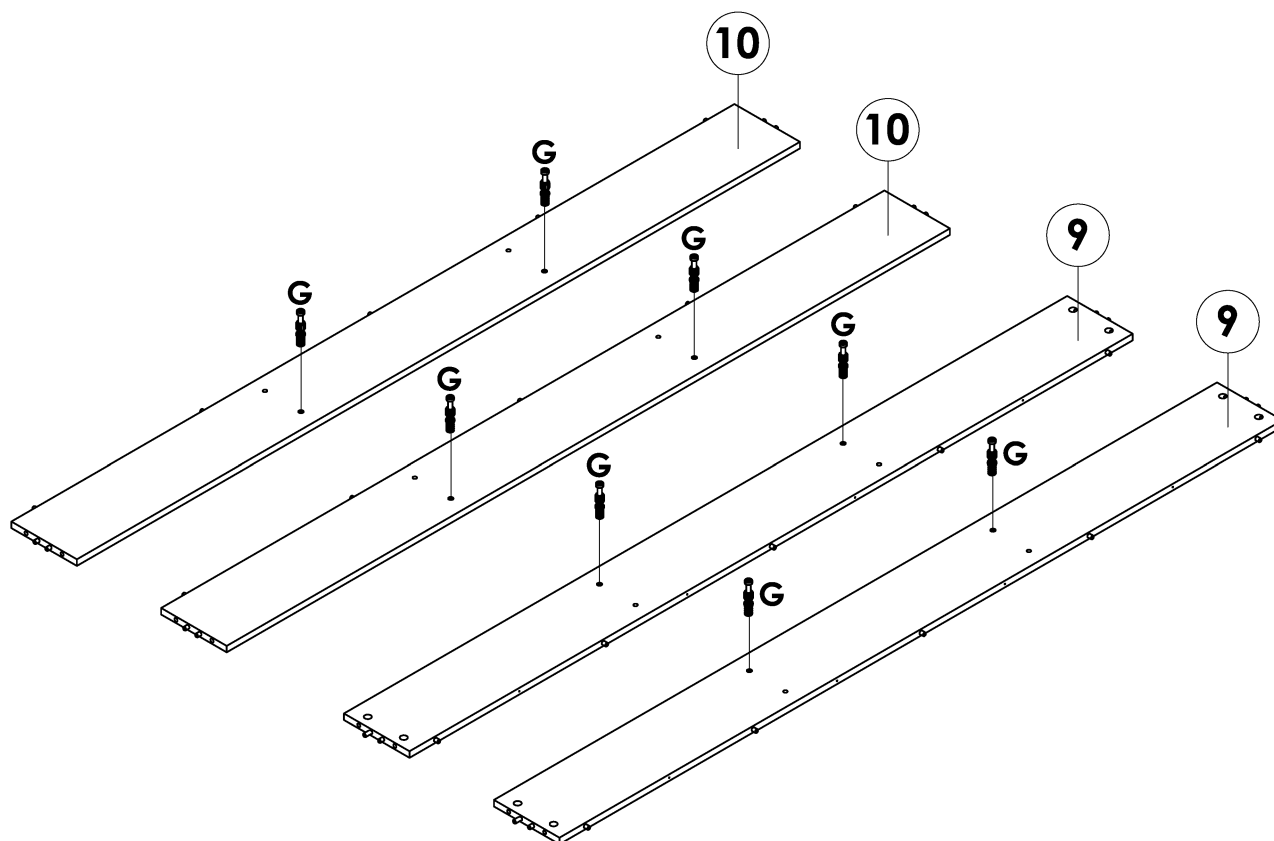
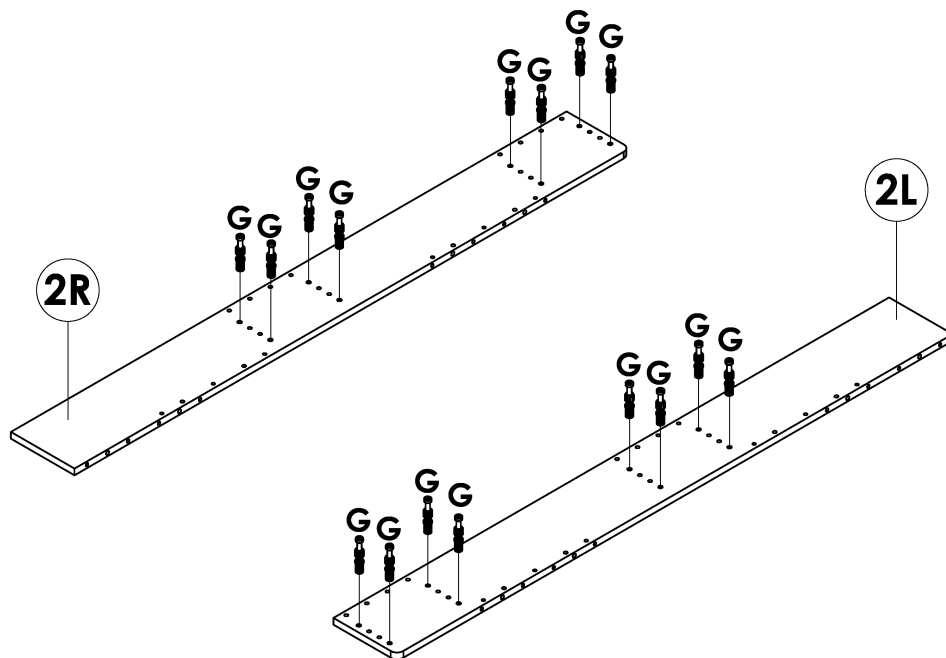

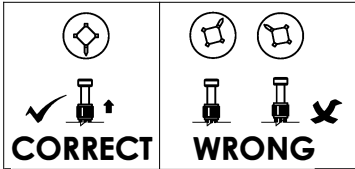

WHEN FITTING CAMS

ENSURE STARTING POSITION IS CORRECT BEFORE YOU INSERT CONNECTING BOLT TURN CLOCKWISE UNTIL SECURE.

H		8
N		8

STEP 3

DO NOT use any power tools as this may damage the bed frame and will invalidate any claim. Attach and secure **Divider** onto **Top Shelf** and **Bottom Shelf** and insert **(H)**, tighten it up by using a Crosshead Screw Driver. Follow it up by attaching **(N)** into screw holes.

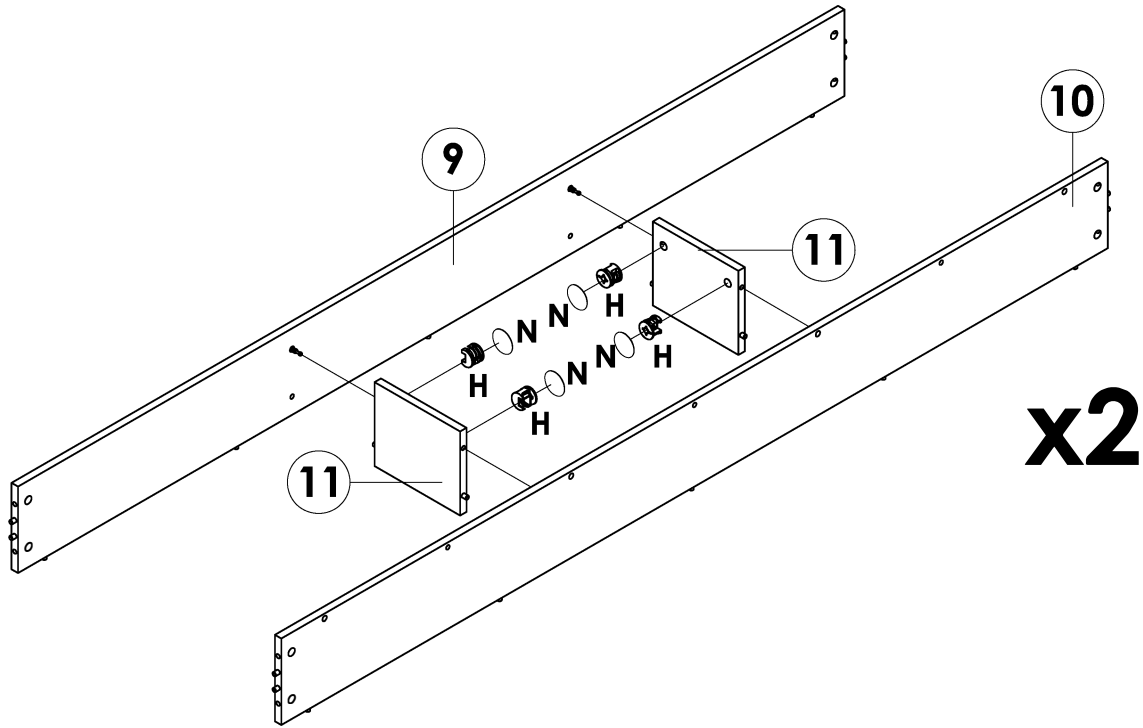

STEP 4

DO NOT use any power tools as this may damage the bed frame and will invalidate any claim.

Attach and secure **Back Panel** onto **Top Shelf**, **Bottom Shelf** and **Divider** by using **(L)**, tighten it up by using Crosshead Screw Driver.

L		20
---	--	----

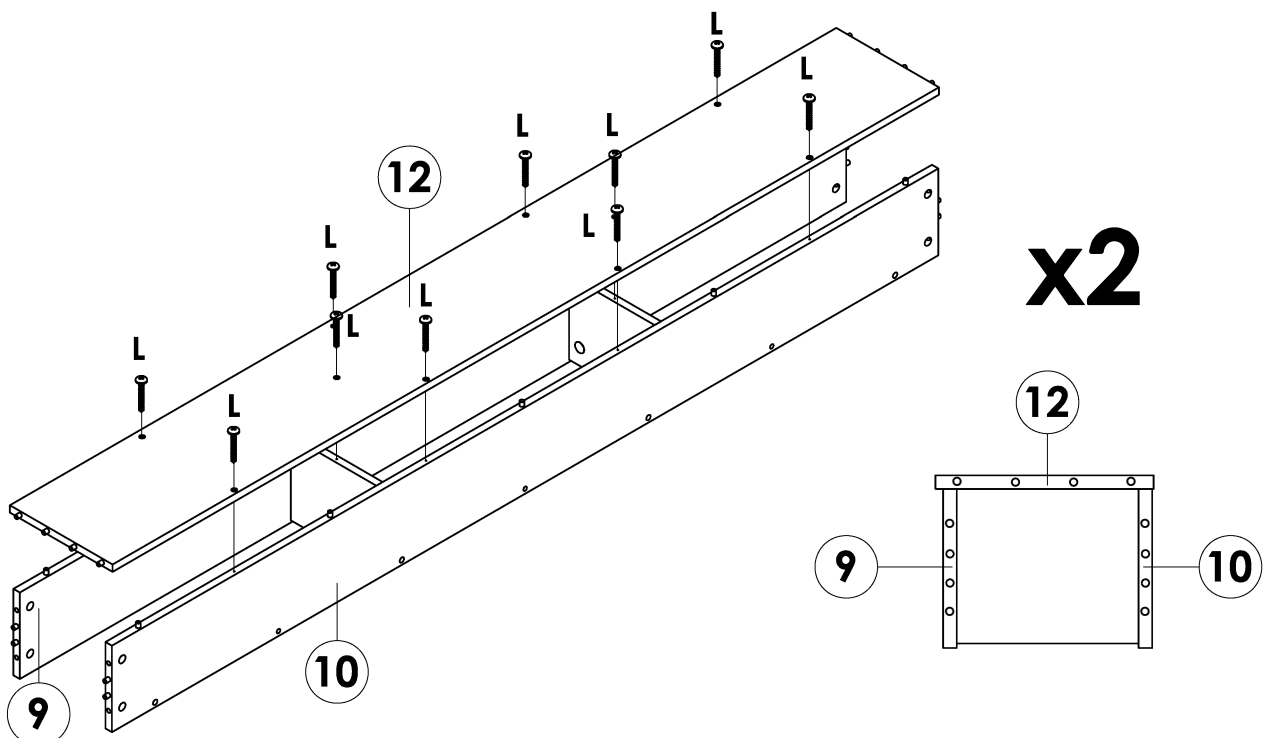

STEP 5

DO NOT use any power tools as this may damage the bed frame and will invalidate any claim.

Insert **(G)** into Ø10MM Holes on **Bottom Shelf**, tighten it up by using crosshead screw driver.

G		8
----------	---	----------

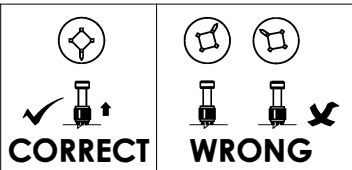
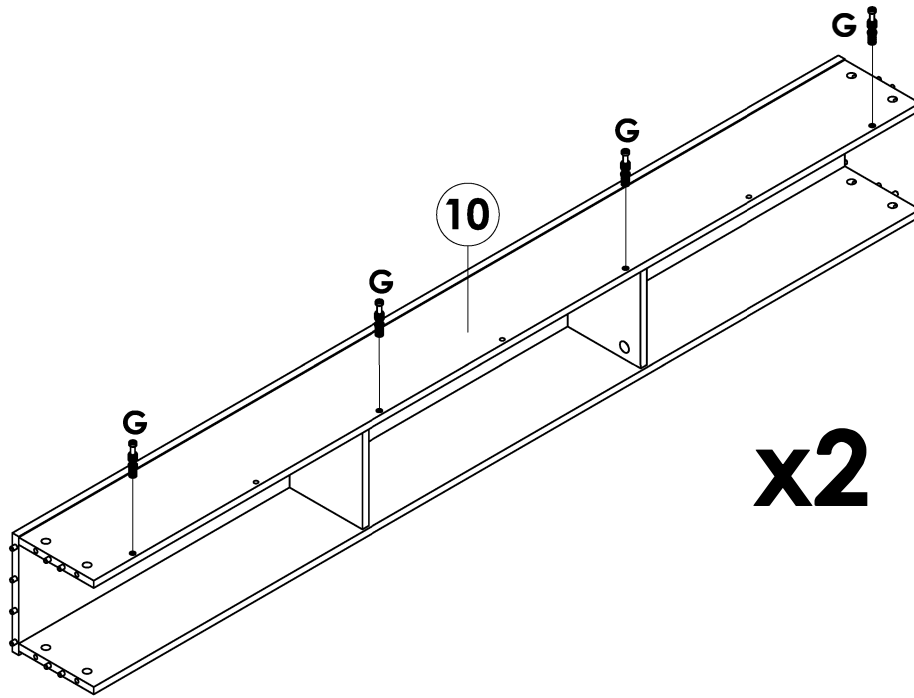

WHEN FITTING CAMS

ENSURE STARTING POSITION IS CORRECT BEFORE YOU INSERT CONNECTING BOLT TURN CLOCKWISE UNTIL SECURE.

H		8
----------	---	----------

STEP 6

DO NOT use any power tools as this may damage the bed frame and will invalidate any claim.

Attach and secure **Full Guard Rail** onto **Bottom Shelf** and insert **(H)**, tighten it up by using a Crosshead Screw Driver.

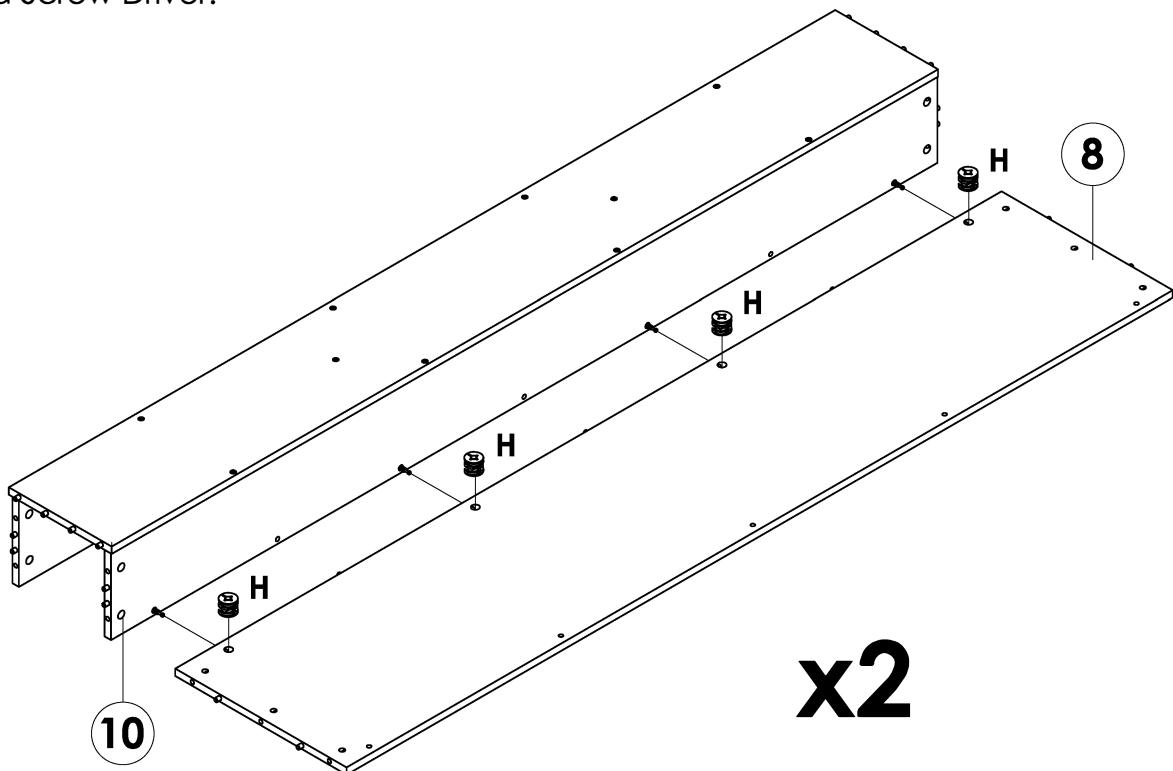

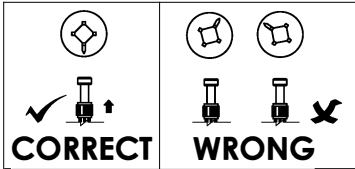

WHEN FITTING CAMS

ENSURE STARTING POSITION IS CORRECT
BEFORE YOU INSERT CONNECTING BOLT
TURN CLOCKWISE UNTIL SECURE.

C		12
D		12
H		8
N		12
P		1

STEP 7

DO NOT use any power tools as this may damage the bed frame and will invalidate any claim.

Attach and secure **Full Guard Rail, Top Shelf, Bottom Shelf** and **Back Panel** onto **Headboard Post (Rear Left)** and **Headboard Post (Rear Right)** by using **(C)** and **(D)**, tighten it up by using **(P)**. Follow it up by attaching **(N)** into screw holes.

Insert **(H)**, tighten it up by using crosshead screw driver.

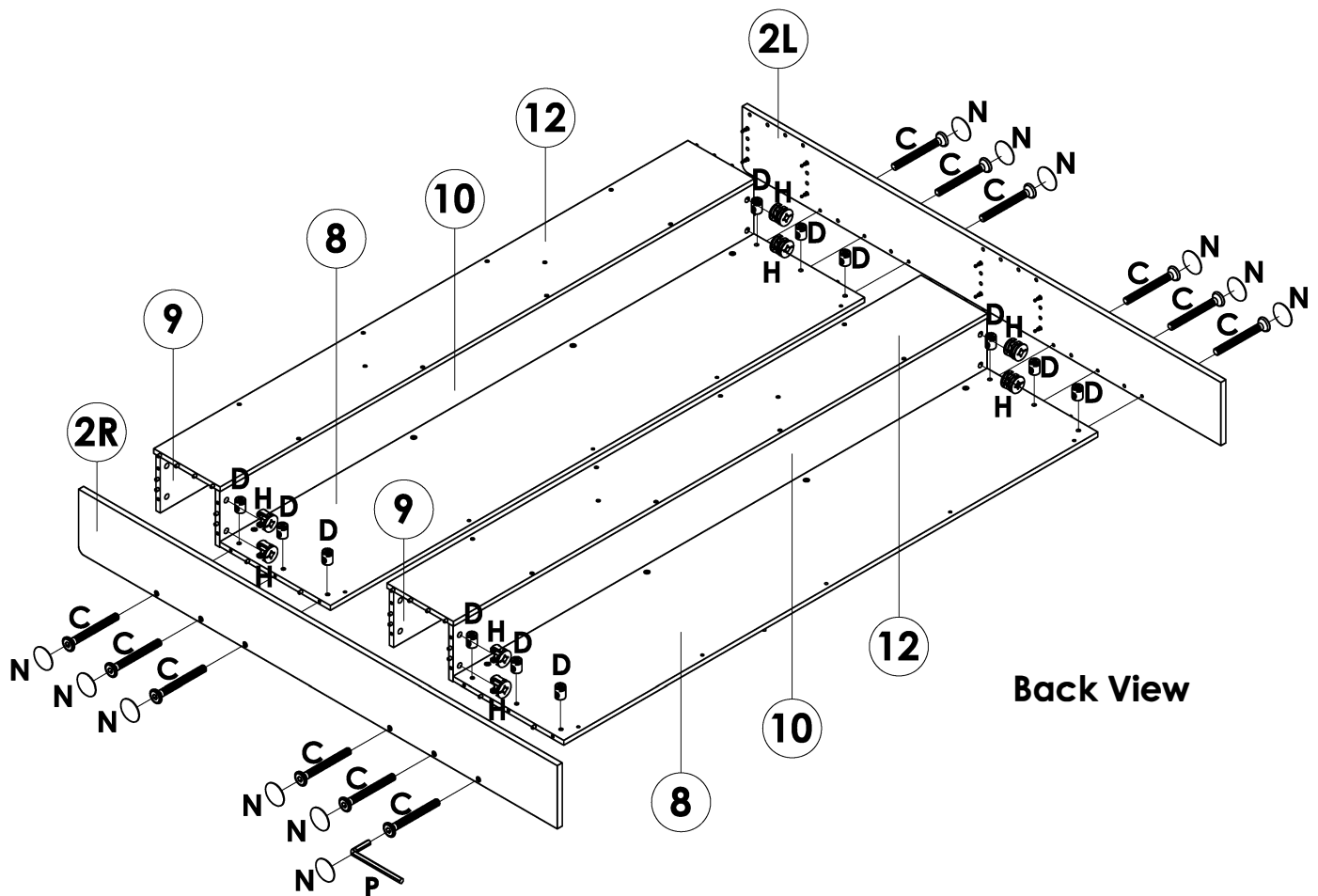

Back View

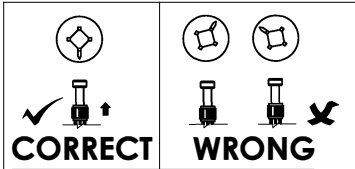

WHEN FITTING CAMS

ENSURE STARTING POSITION IS CORRECT BEFORE YOU INSERT CONNECTING BOLT TURN CLOCKWISE UNTIL SECURE.

H



8

STEP 8

DO NOT use any power tools as this may damage the bed frame and will invalidate any claim. Insert (H) onto **Top Shelf**, tighten it up by using crosshead screw driver.

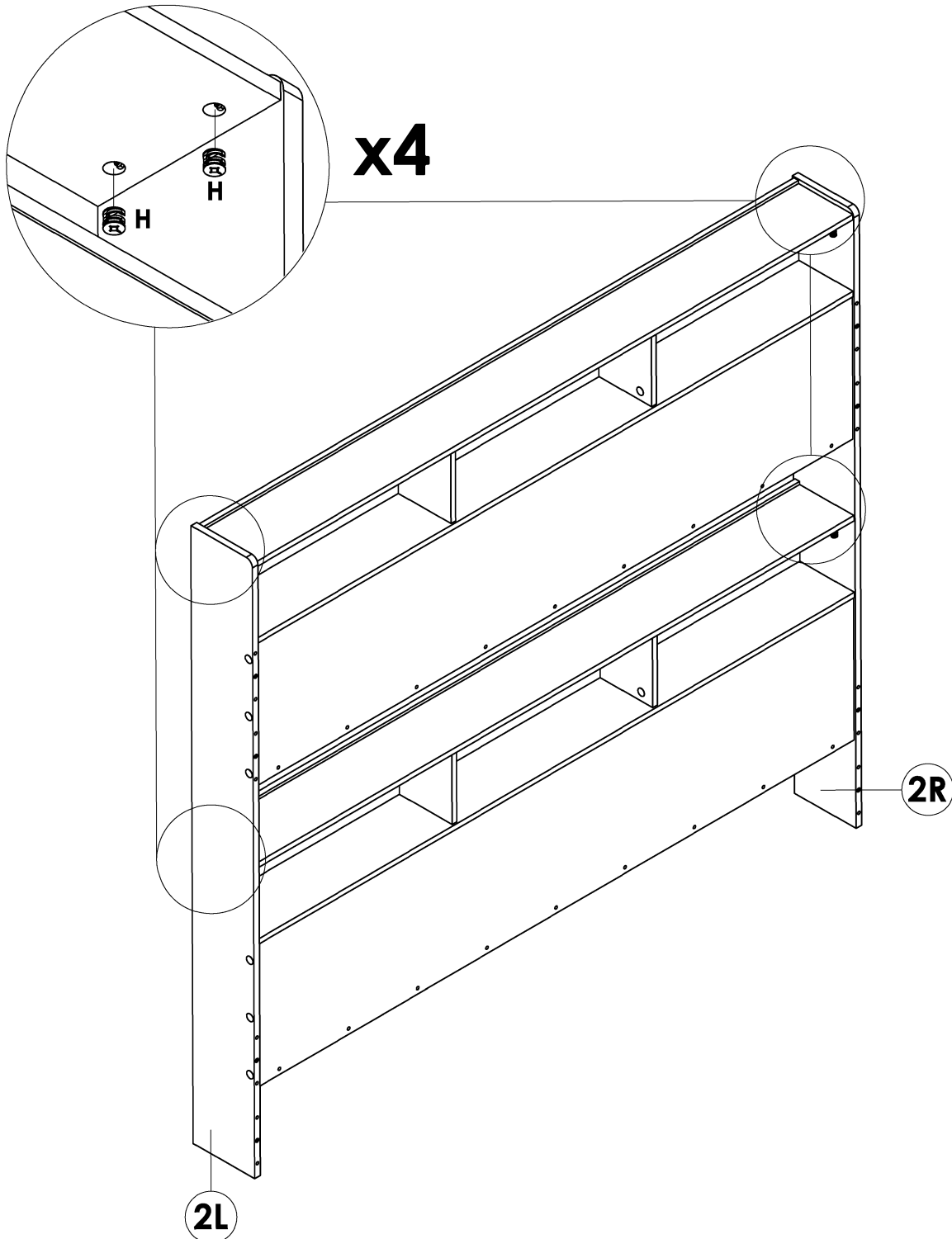

STEP 9

DO NOT use any power tools as this may damage the bed frame and will invalidate any claim.

G



16

Insert **(G)** into $\varnothing 10\text{MM}$ holes on **Headboard Post (Front Left), Headboard Post (Front Right), Headboard Post (Rear Left)** and **Headboard Post (Rear Right)**, tighten it up by using crosshead screw driver.

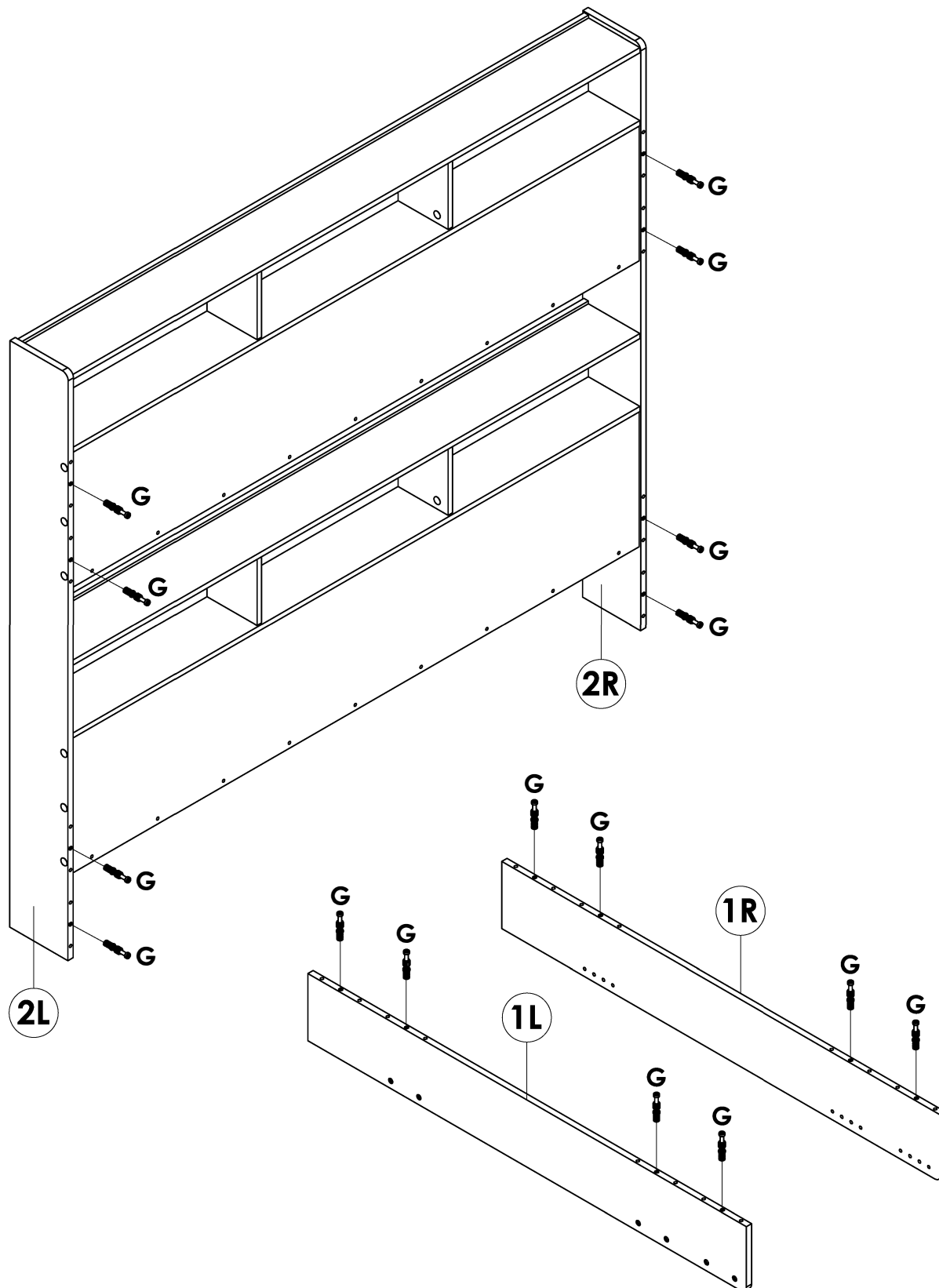

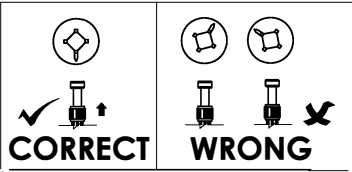

WHEN FITTING CAMS

ENSURE STARTING POSITION IS CORRECT BEFORE YOU INSERT CONNECTING BOLT TURN CLOCKWISE UNTIL SECURE.

H		16
N		16

STEP 10



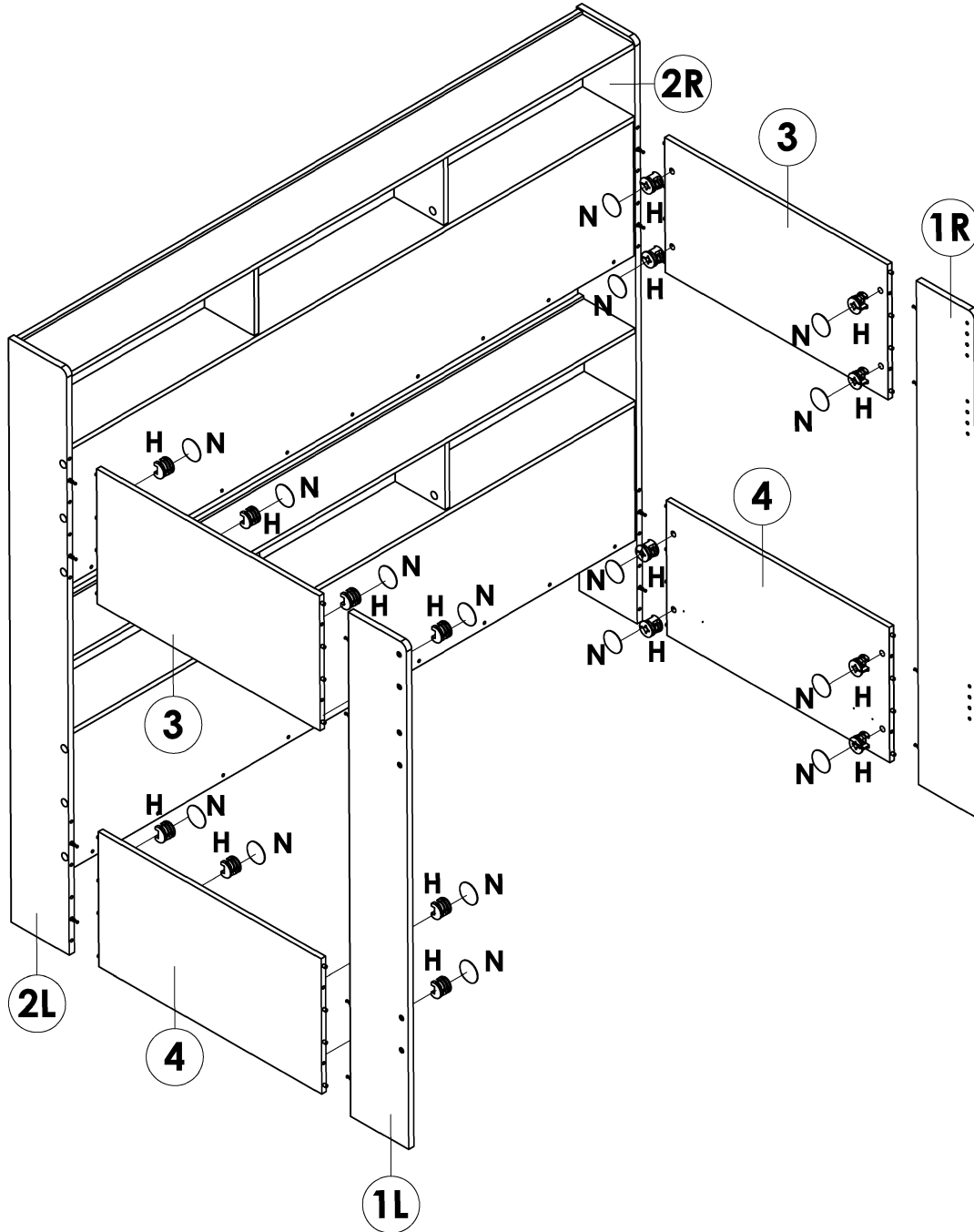

DO NOT use any power tools as this may damage the bed frame and will invalidate any claim. Attach and secure **Headboard Panel (Top)** and **Headboard Panel (Bottom)** onto **Headboard Post (Front Left)**, **Headboard Post (Front Right)**, **Headboard Post (Rear Left)** and **Headboard Post (Rear Right)** and insert (H), tighten it up by using a Crosshead Screw Driver. Follow it up by attaching (N) into screw holes.



STEP 11

DO NOT use any power tools as this may damage the bed frame and will invalidate any claim.

Attach and secure **Side Rail (Front)** onto **Headboard (L/R)** by using **(C)** and **(D)**, tighten it up by using **(P)**. Follow it up by attaching **(N)** into screw holes.

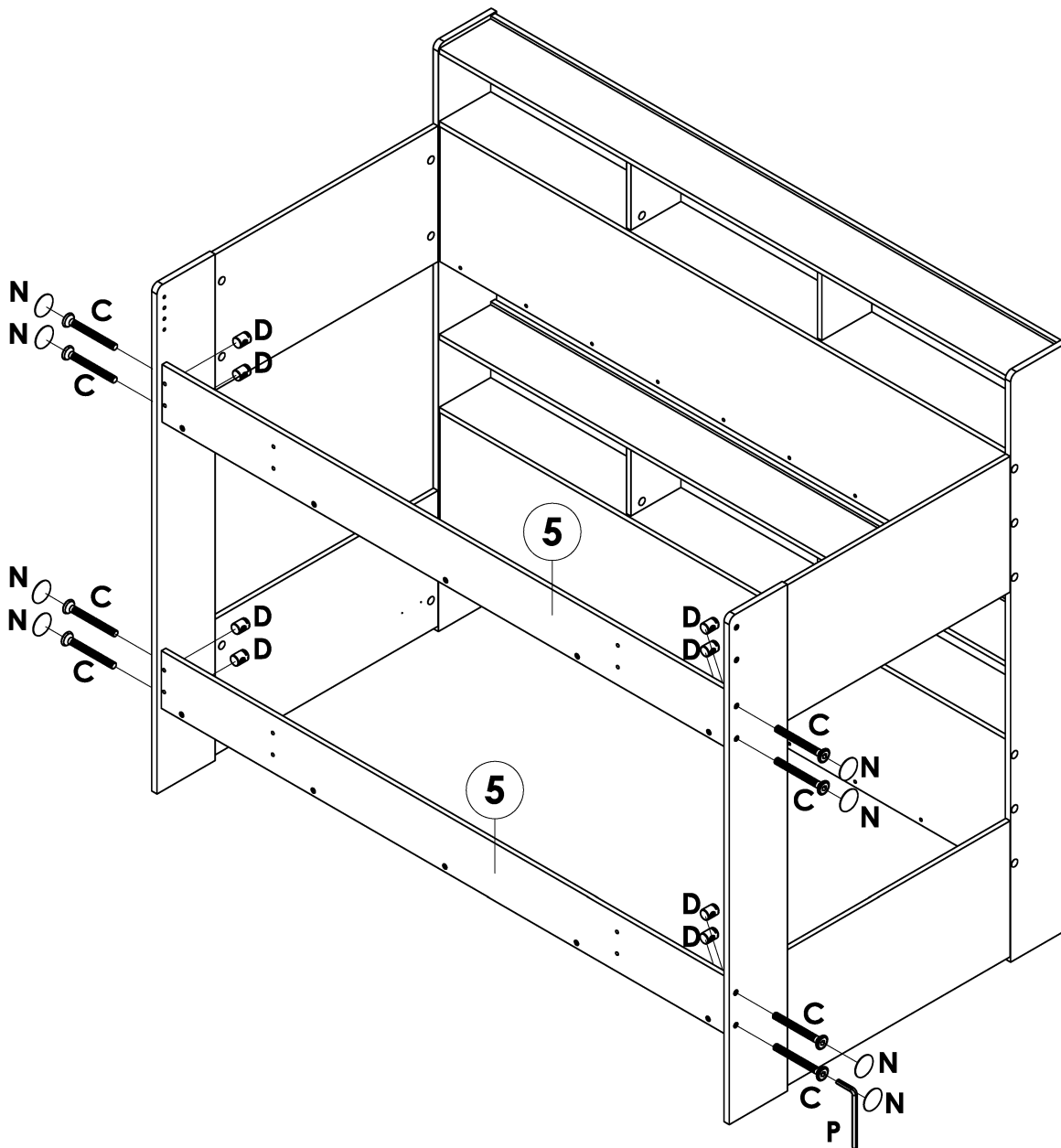

C		8
D		8
N		8
P		1



STEP 12

DO NOT use any power tools as this may damage the bed frame and will invalidate any claim.

Attach and secure **Slat Support** onto **Side Rail (Front)** and **Full Guard Rail** by using **(F)**, tighten it up by using **(P)**. Follow it up by attaching **(N)** into screw holes.

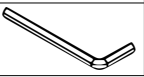
F		20
N		10
P		1

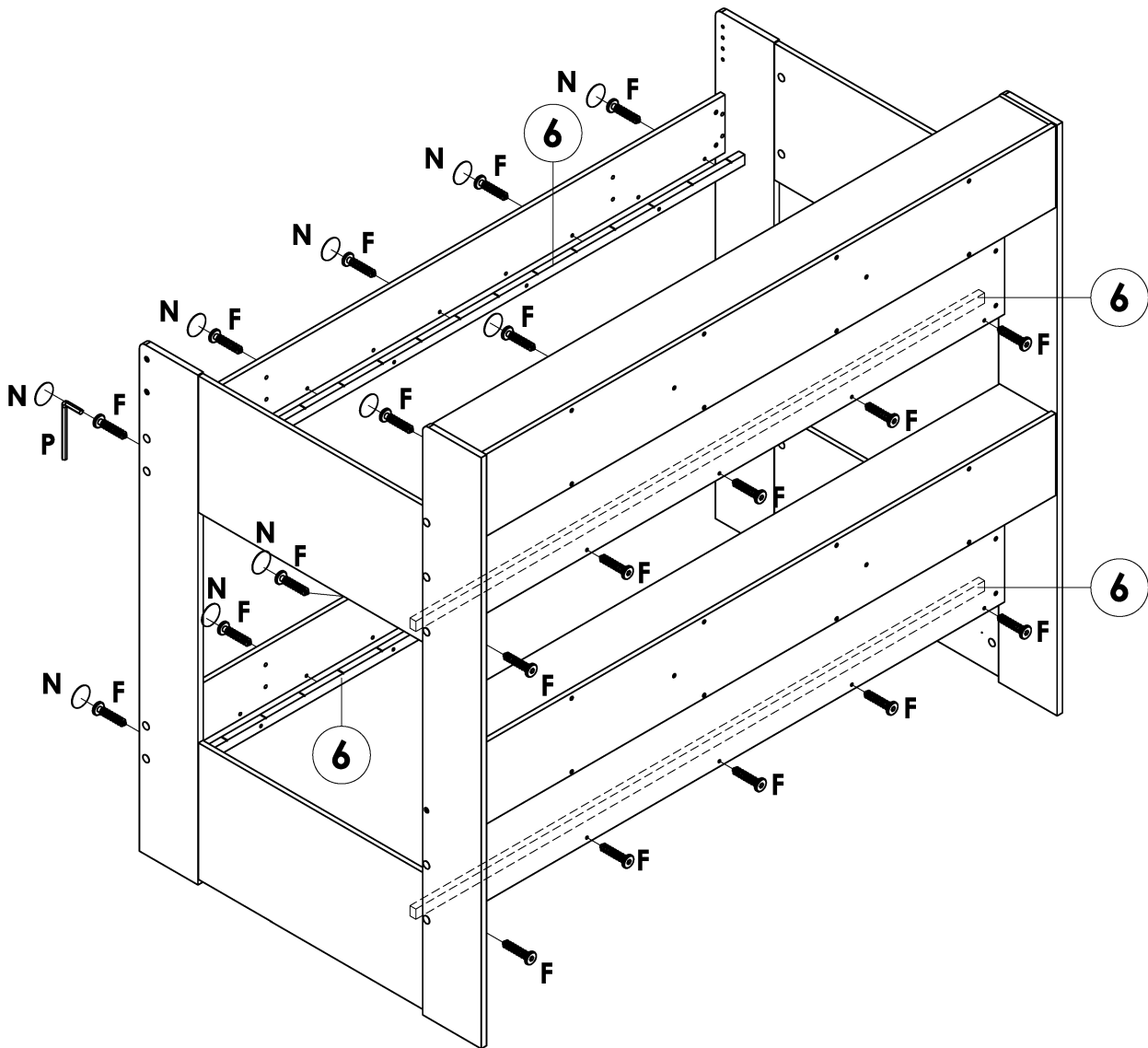

STEP 13

DO NOT use any power tools as this may damage the bed frame and will invalidate any claim.

K



4



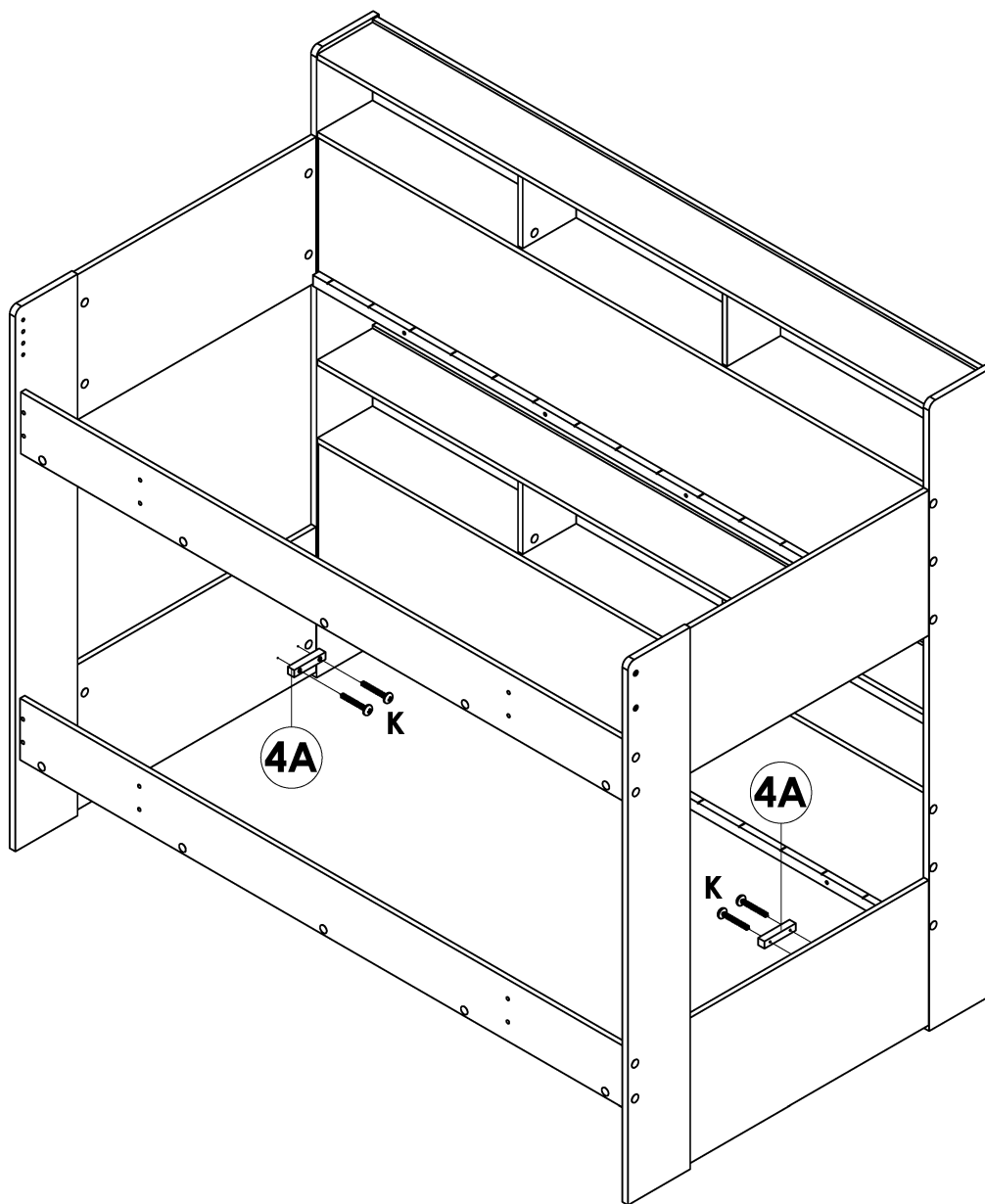

Attach and secure **Stopper** onto **Headboard (L/R)** by using **(K)**, tighten it up by using Crosshead Screw Driver.



STEP 14

DO NOT use any power tools as this may damage the bed frame and will invalidate any claim.

Attach and secure **Ladder Side (Left)** and **Ladder Side (Right)** onto **Ladder Slat** by using **(C)** and **(D)**, tighten it up by using **(P)**. Follow it up by attaching **(N)** into screw holes.

C		6
D		6
N		6
P		1

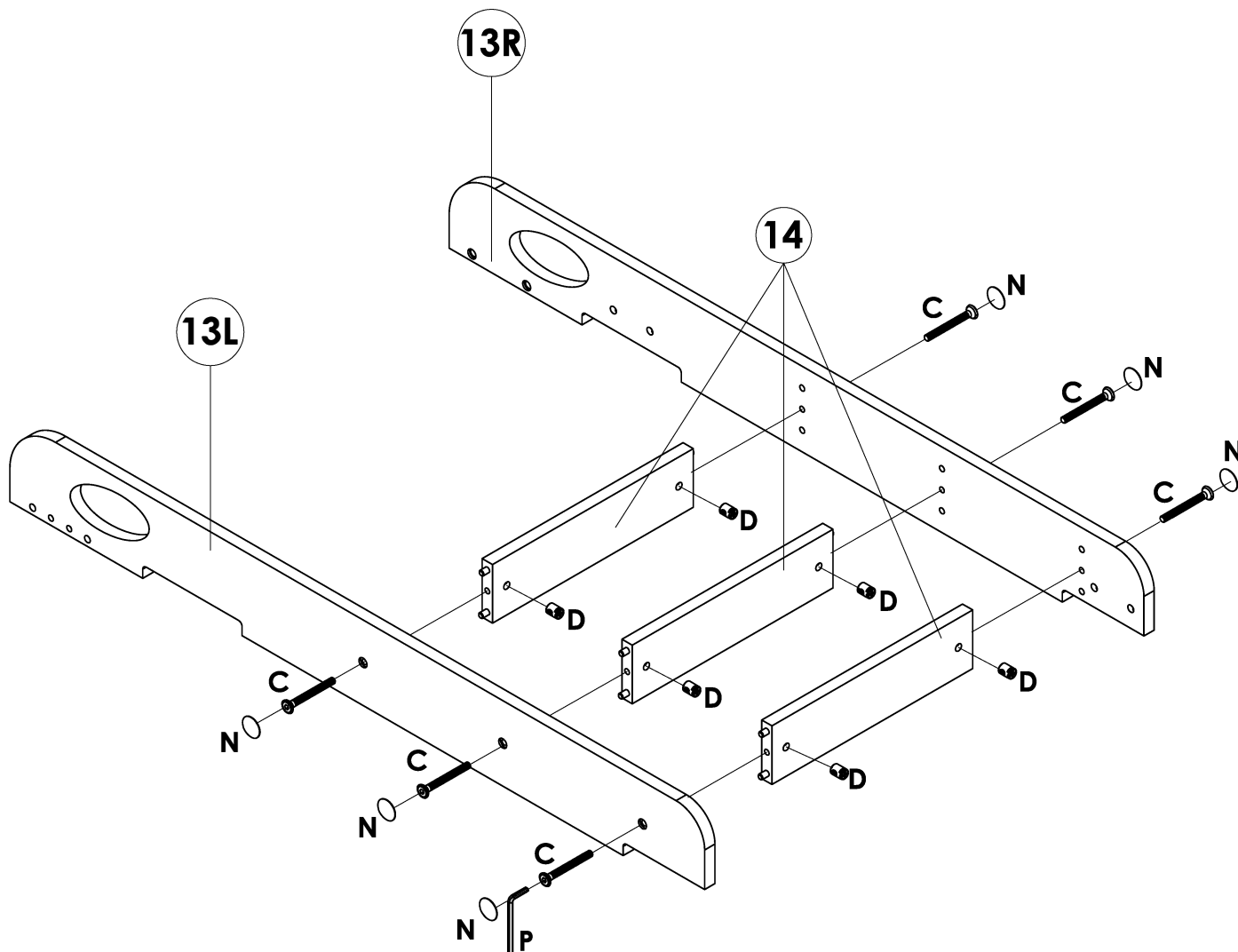



OPTION 1 : LEFT SIDE LADDER

STEP 15

DO NOT use any power tools as this may damage the bed frame and will invalidate any claim.

Attach and secure **Ladder** onto **Side Rail (Front)** by using **(C)** and **(D)**, tighten it up by using **(P)**.



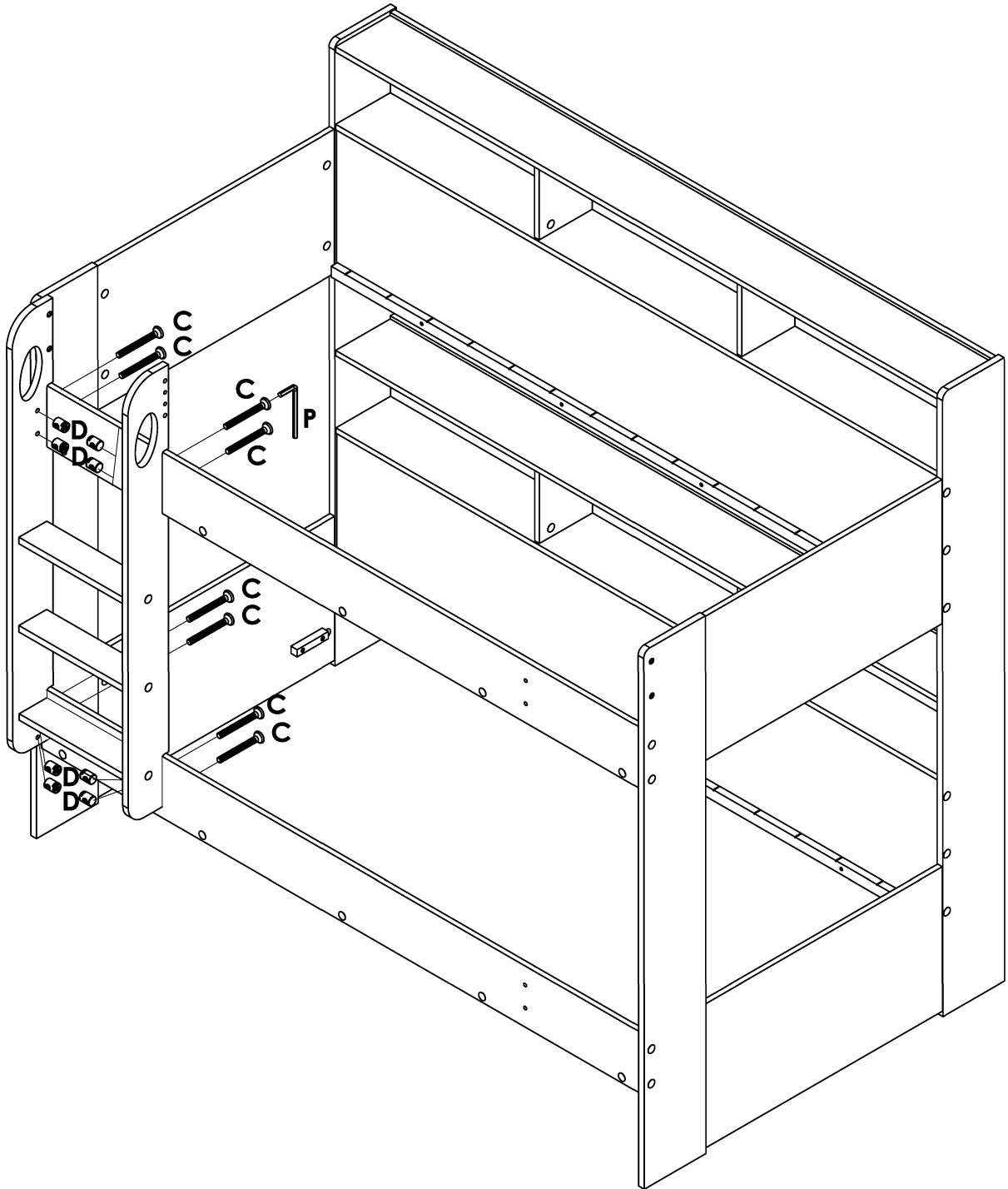

C		8
D		8
P		1



STEP 16

DO NOT use any power tools as this may damage the bed frame and will invalidate any claim.

Attach and secure **Ladder** onto **Headboard (L)** by using **(B)** and **(E)**, tighten it up by using **(P)**. Follow it up by attaching **(N)** into screw holes.

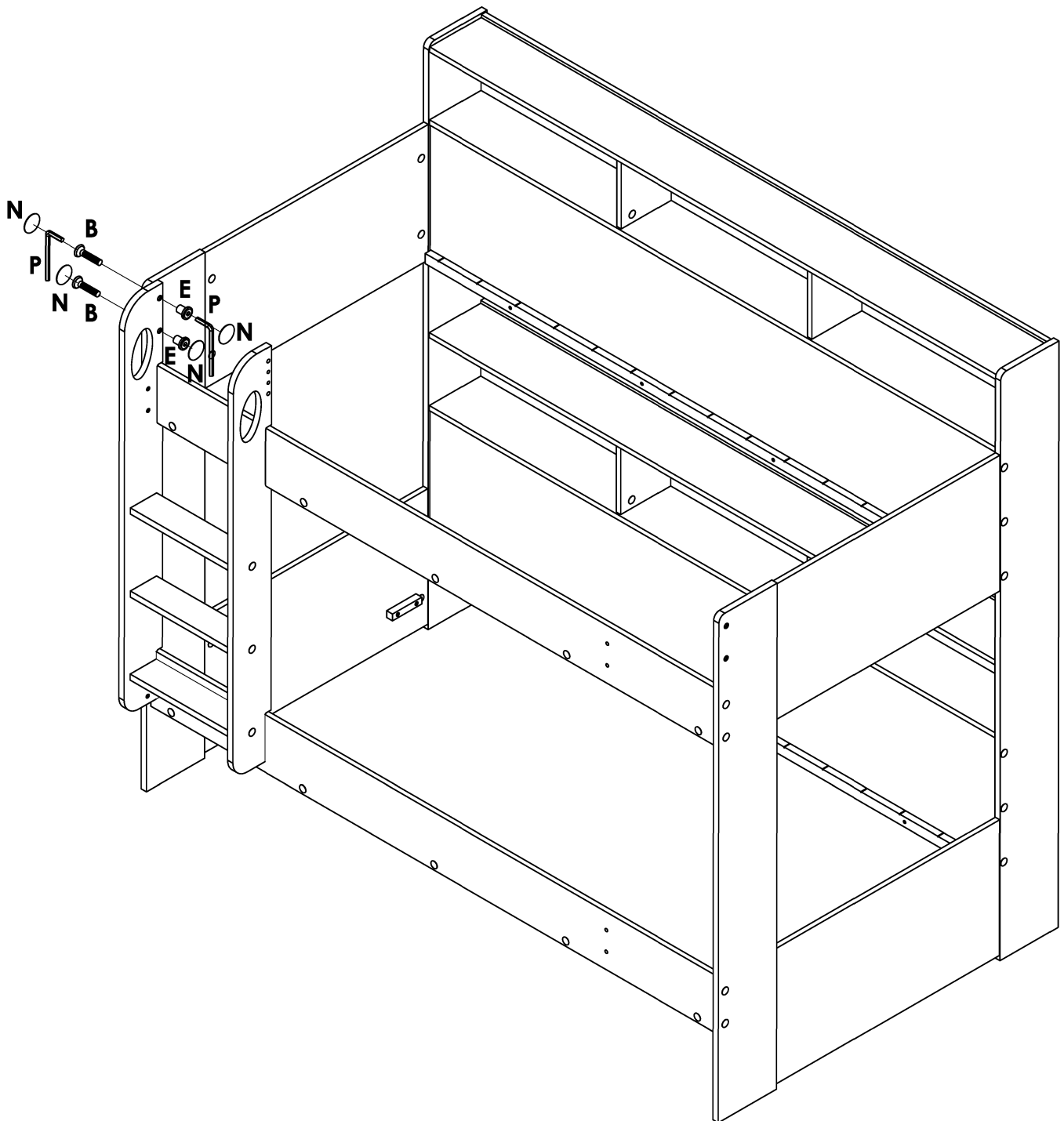

B		2
E		2
N		4
P		2



STEP 17

DO NOT use any power tools as this may damage the bed frame and will invalidate any claim.

Attach and secure **Semi Guard Rail** onto **Headboard (R)** and **Ladder** by using **(C)** and **(D)**, tighten it up by using **(P)**. Follow it up by attaching **(N)** into screw holes.

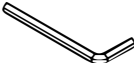
C		4
D		4
N		4
P		1

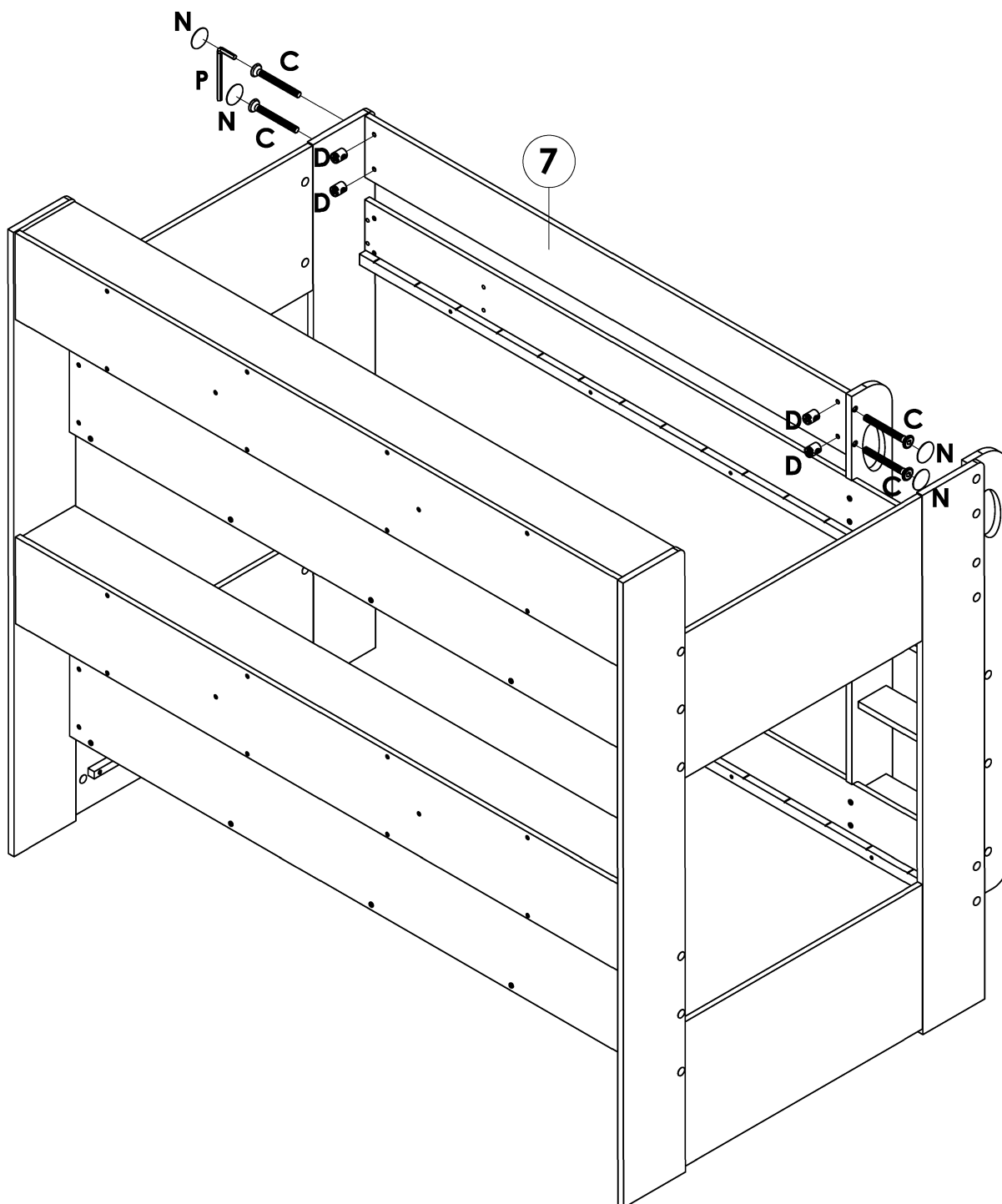

STEP 18

DO NOT use any power tools as this may damage the bed frame and will invalidate any claim.

Attach and secure **Wooden Slat** onto bed **Slat Support** by using **(J)**, tighten it up by using a Crosshead Screw Driver.

J



60

Align both **Side Rail (Front) & **Full Guard Rail** before tightening the screws.*

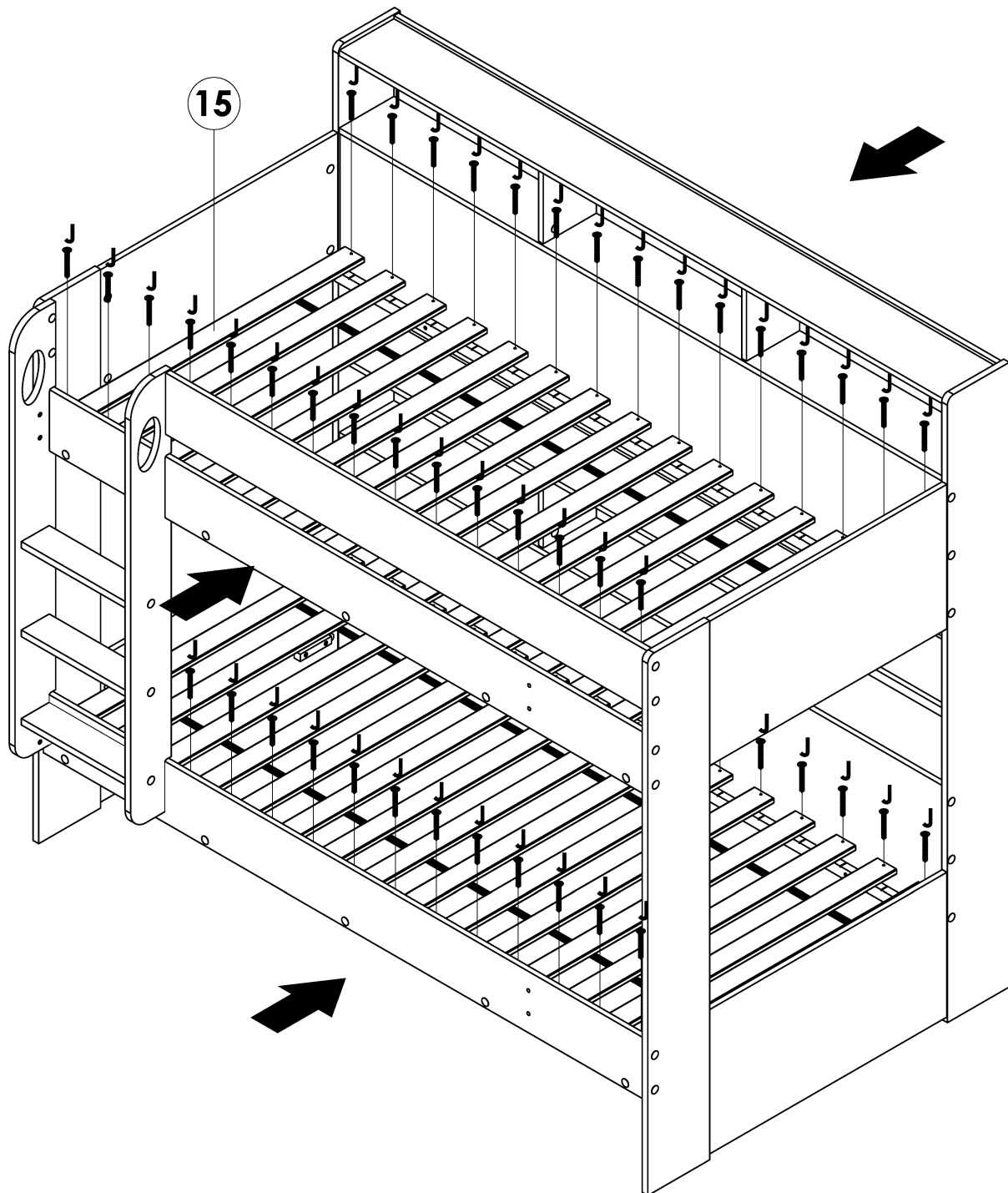

STEP 19

Attaching **(N)** into $\text{\O}9\text{MM}$ holes on **Side Rail (Front)**.

N		8
---	---	---

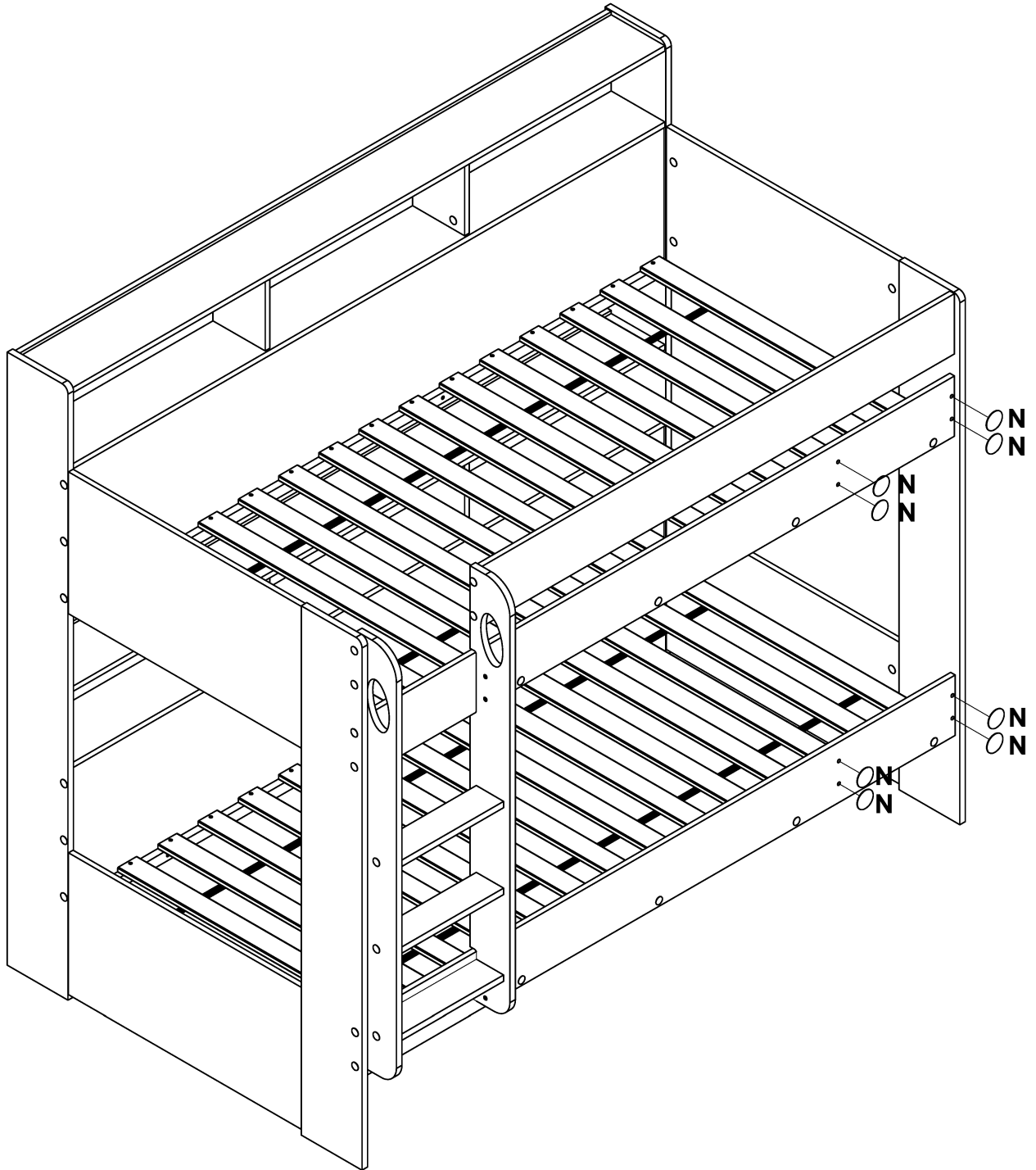



OPTION 2 : RIGHT SIDE LADDER

STEP 15

DO NOT use any power tools as this may damage the bed frame and will invalidate any claim.

Attach and secure **Ladder** onto **Side Rail (Front)** by using **(C)** and **(D)**, tighten it up by using **(P)**.



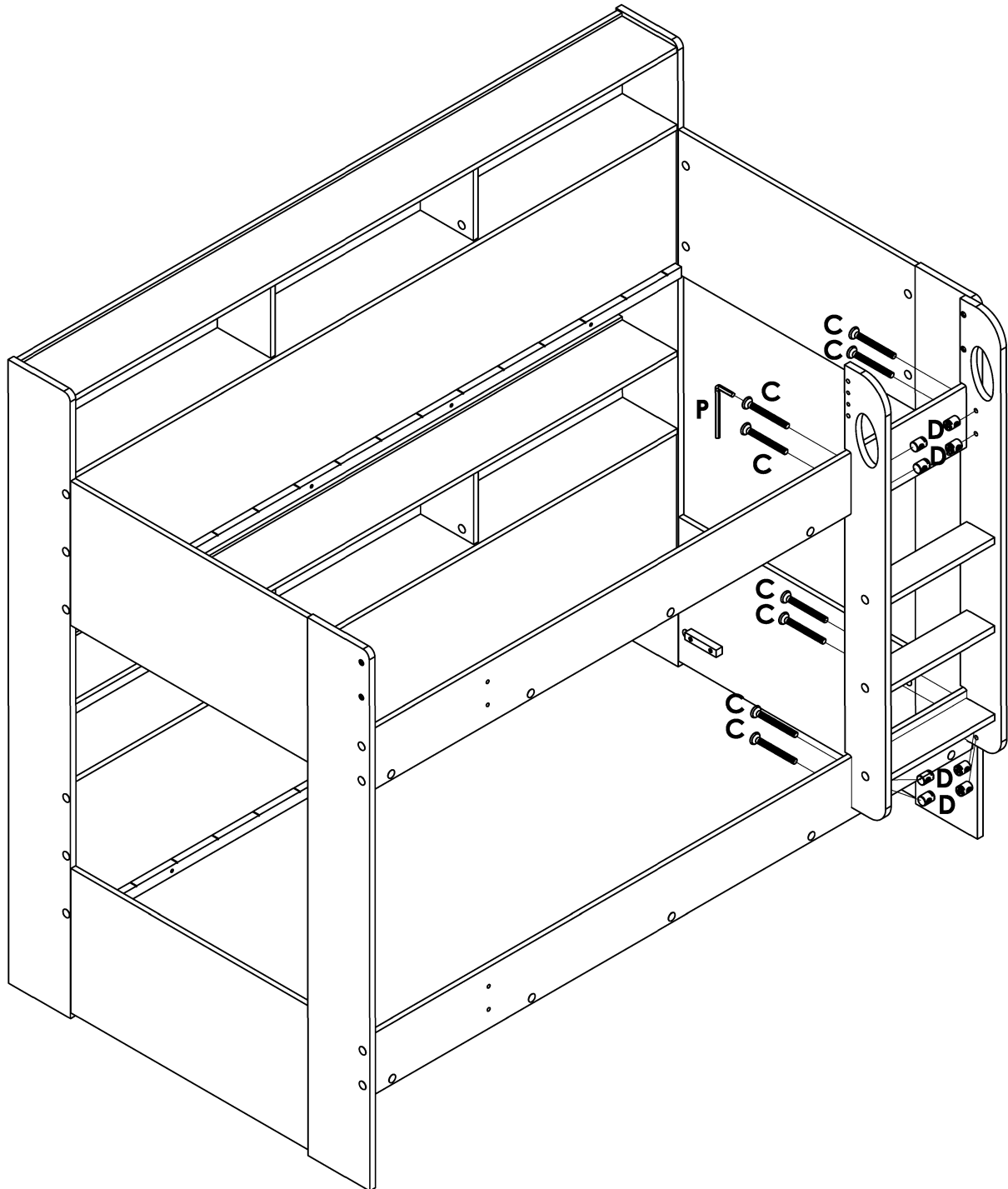

C		8
D		8
P		1



STEP 16

DO NOT use any power tools as this may damage the bed frame and will invalidate any claim.

Attach and secure **Ladder** onto **Headboard (L)** by using **(B)** and **(E)**, tighten it up by using **(P)**. Follow it up by attaching **(N)** into screw holes.



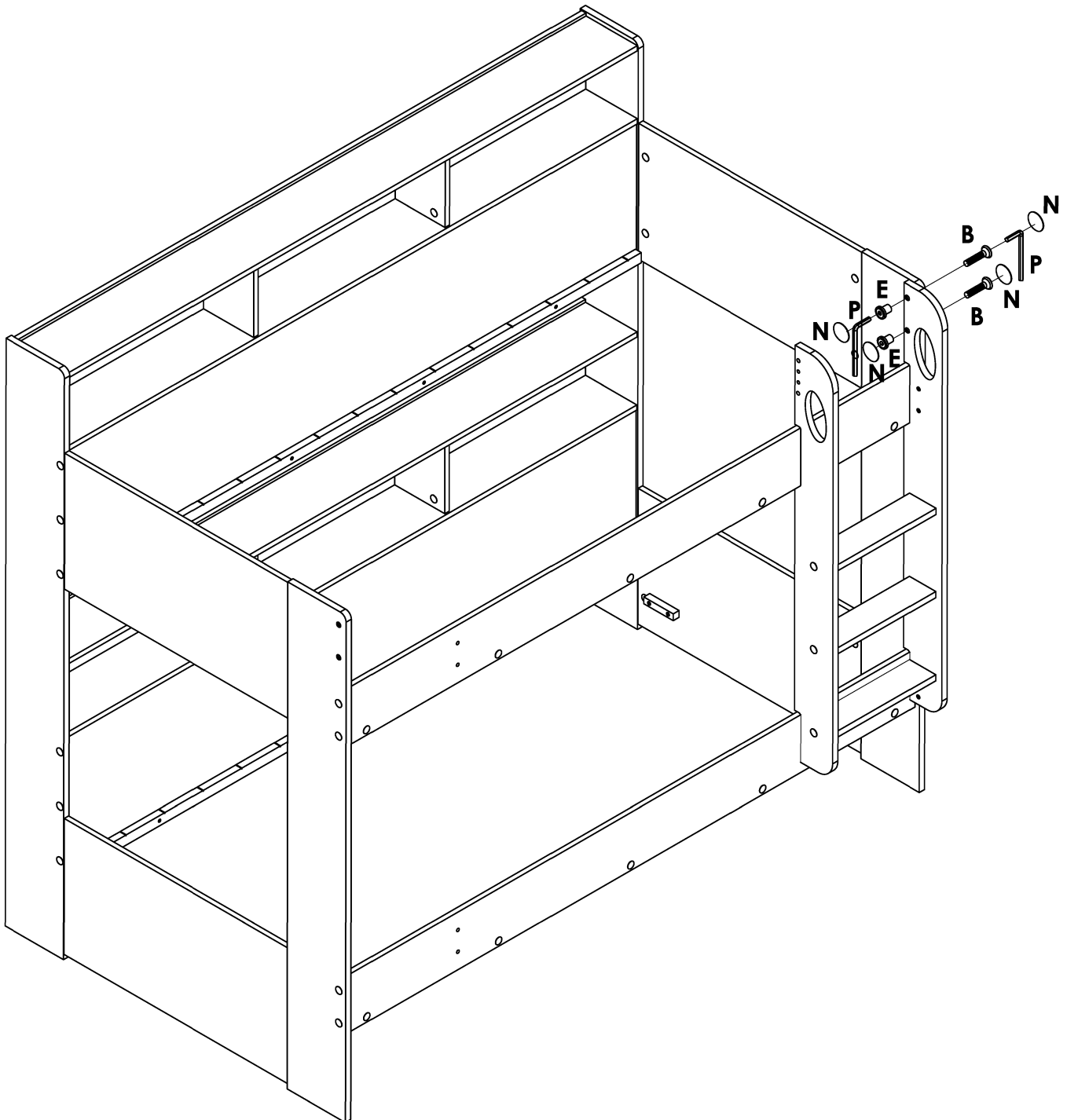

B		2
E		2
N		4
P		2



STEP 17

DO NOT use any power tools as this may damage the bed frame and will invalidate any claim.

Attach and secure **Semi Guard Rail** onto **Headboard (R)** and **Ladder** by using **(C)** and **(D)**, tighten it up by using **(P)**. Follow it up by attaching **(N)** into screw holes.

C		4
D		4
N		4
P		1

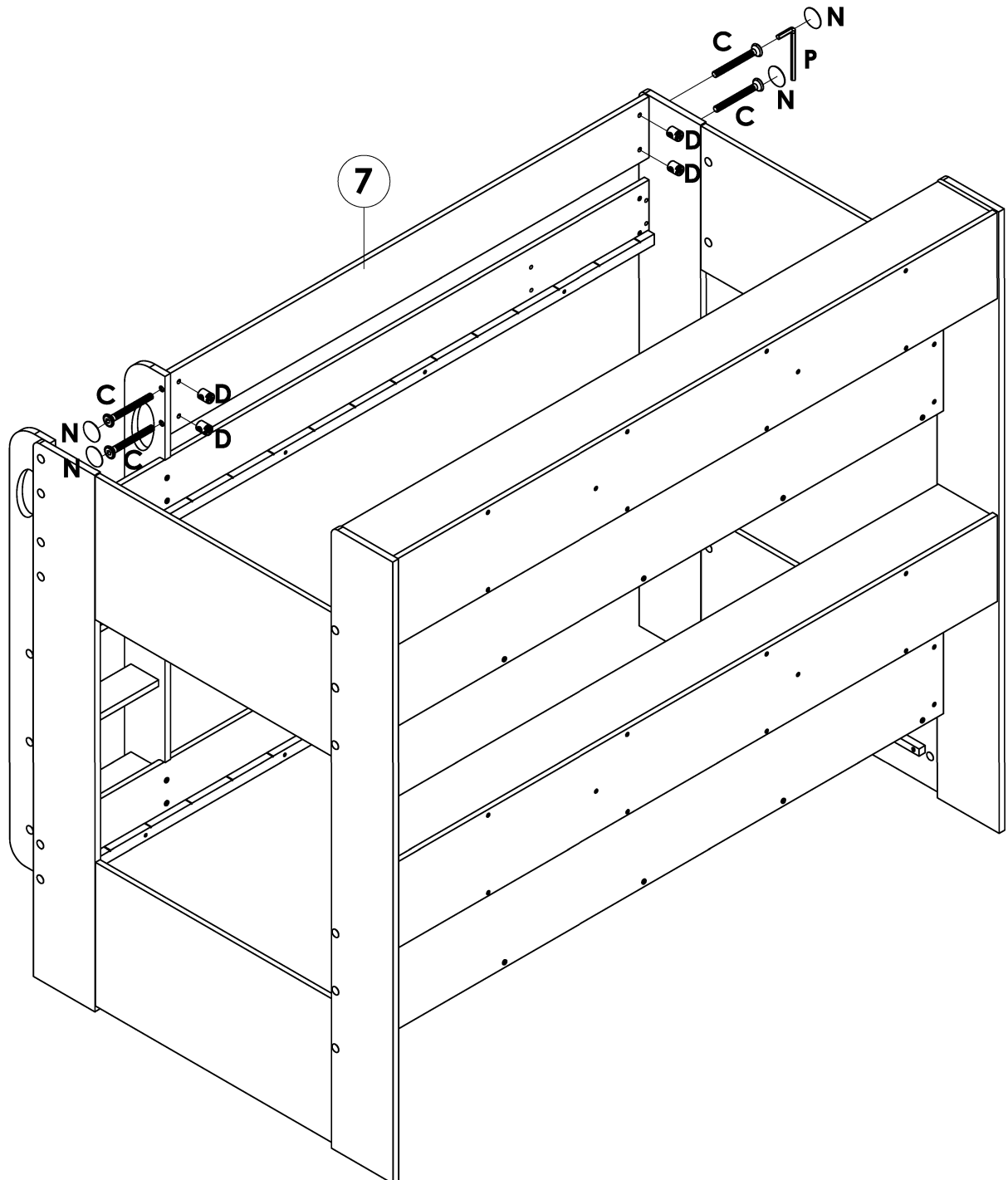

STEP 18

DO NOT use any power tools as this may damage the bed frame and will invalidate any claim.

Attach and secure **Wooden Slat** onto bed **Slat Support** by using **(J)**, tighten it up by using a Crosshead Screw Driver.

J



60

Align both **Side Rail (Front) & **Full Guard Rail** before tightening the screws.*

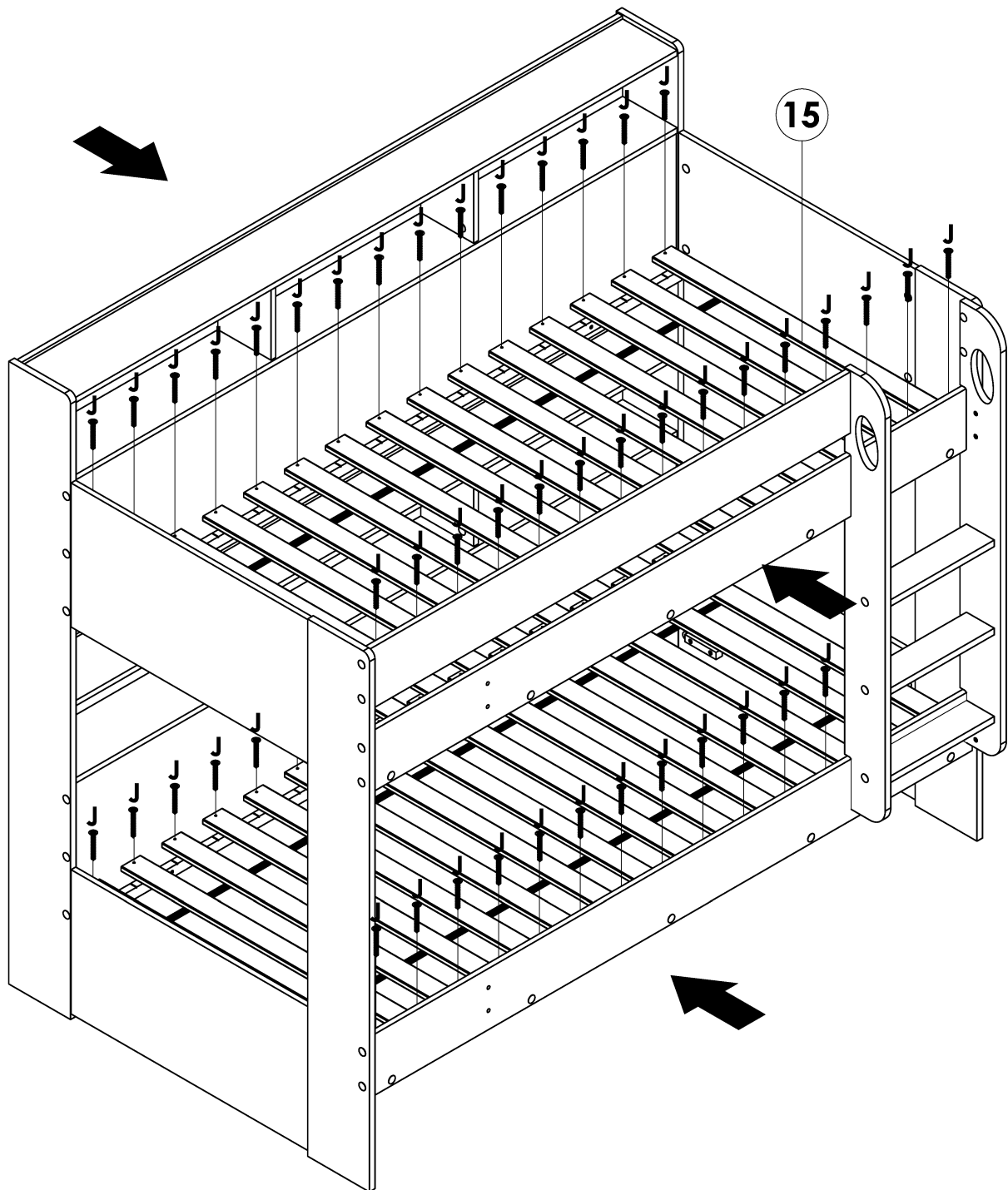

STEP 19

Attaching **(N)** into $\text{\O}9\text{MM}$ holes on **Side Rail (Front)**.

N		8
---	---	---

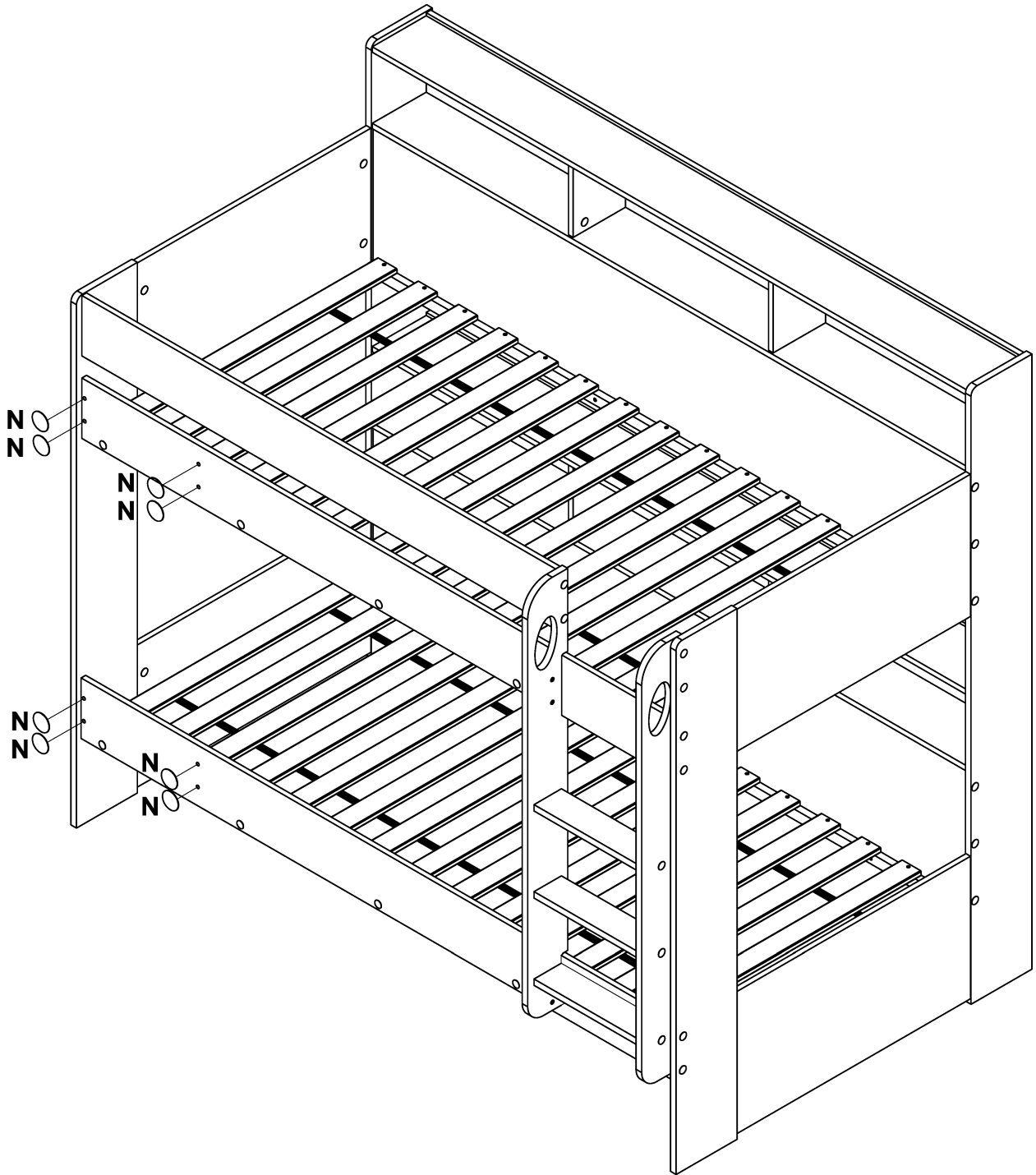

Happy
beds™

Oliver Trundle

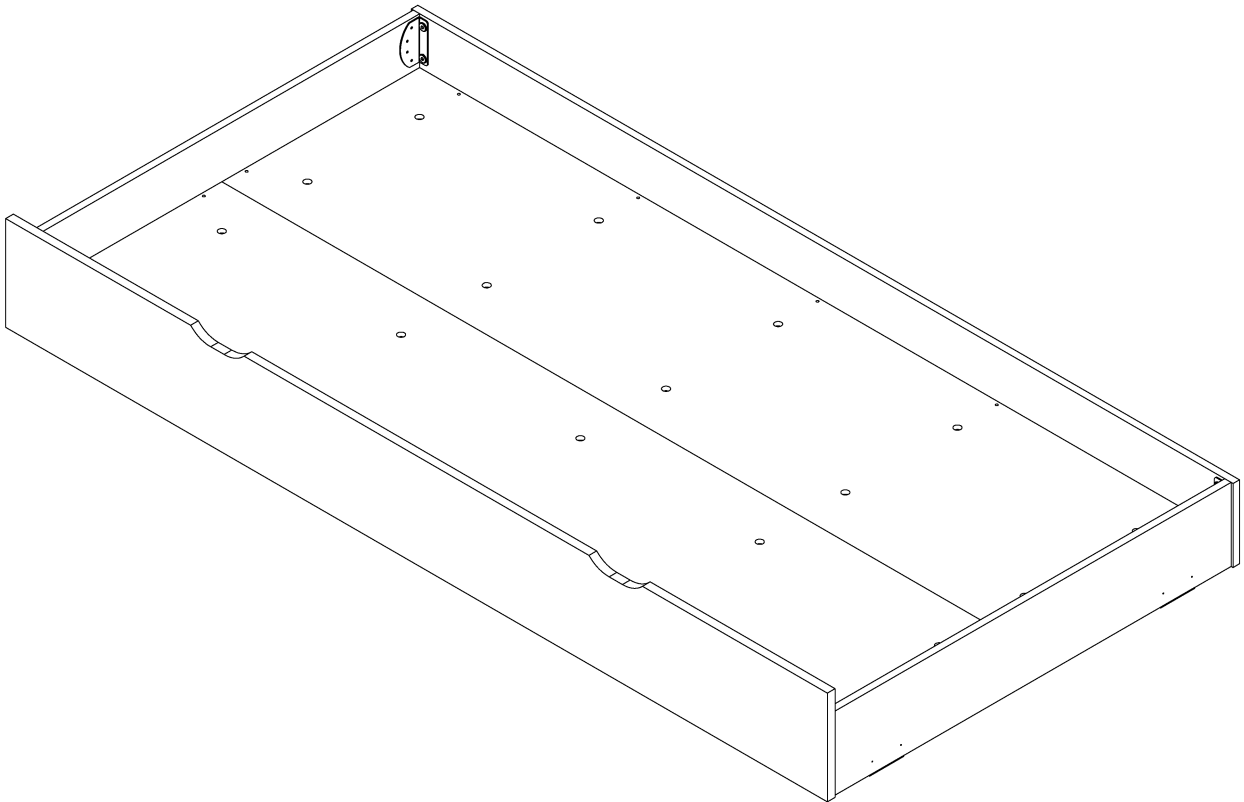

Assembly Instructions

SAFETY ADVICE

Please take the time to carefully read through the whole of these instructions before you commence.

Keep these instructions for future reference.

Unpack, inspect and check of all of the contents.

Please dispose of all packing safely.

Small components parts could choke a child is swallowed.

We strongly recommend that you keep children well away from the work area.

It would be sensible to lay a sheet or blanket on the floor where you intend to work to avoid

Scratching this product and protect your floor.

This product is heavy. Take extreme care when lifting to avoid personal injury or damage to the product.

This bed is heavy. Always lift this bed with two people.

Assemble the product as close to its intended final position in the room as possible.

Keep any sharp object away from the bed frame.

HANDY HINT: If you keep the hardware in a bowl during assembly you will be less likely to lose them.

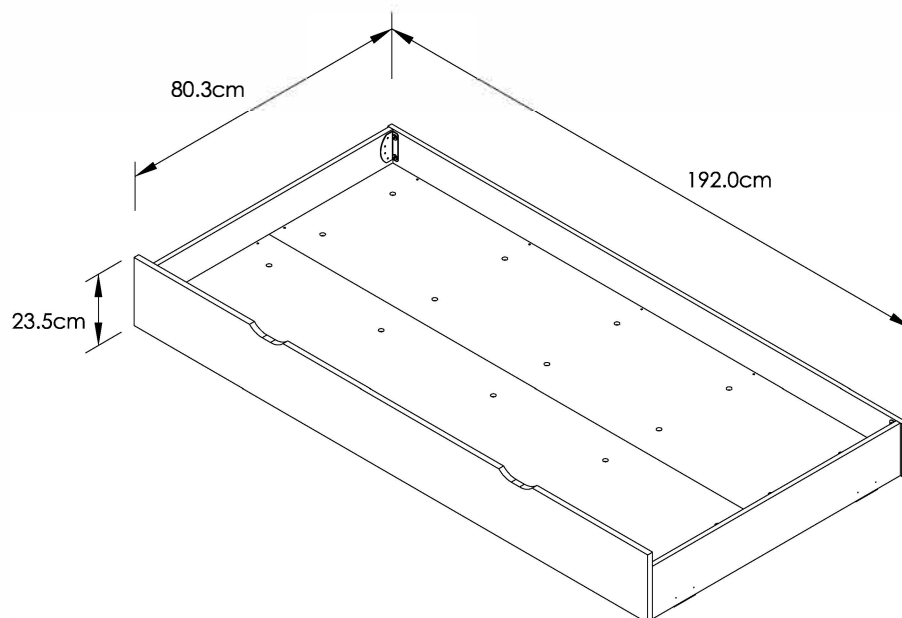

All Dimensions are approximates.

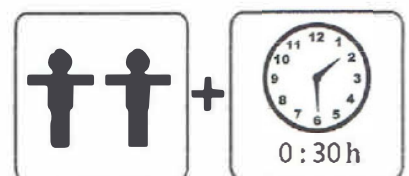

Parts

ALL PARTS ARE LABELLED WITH NUMBER ACCORDINGLY

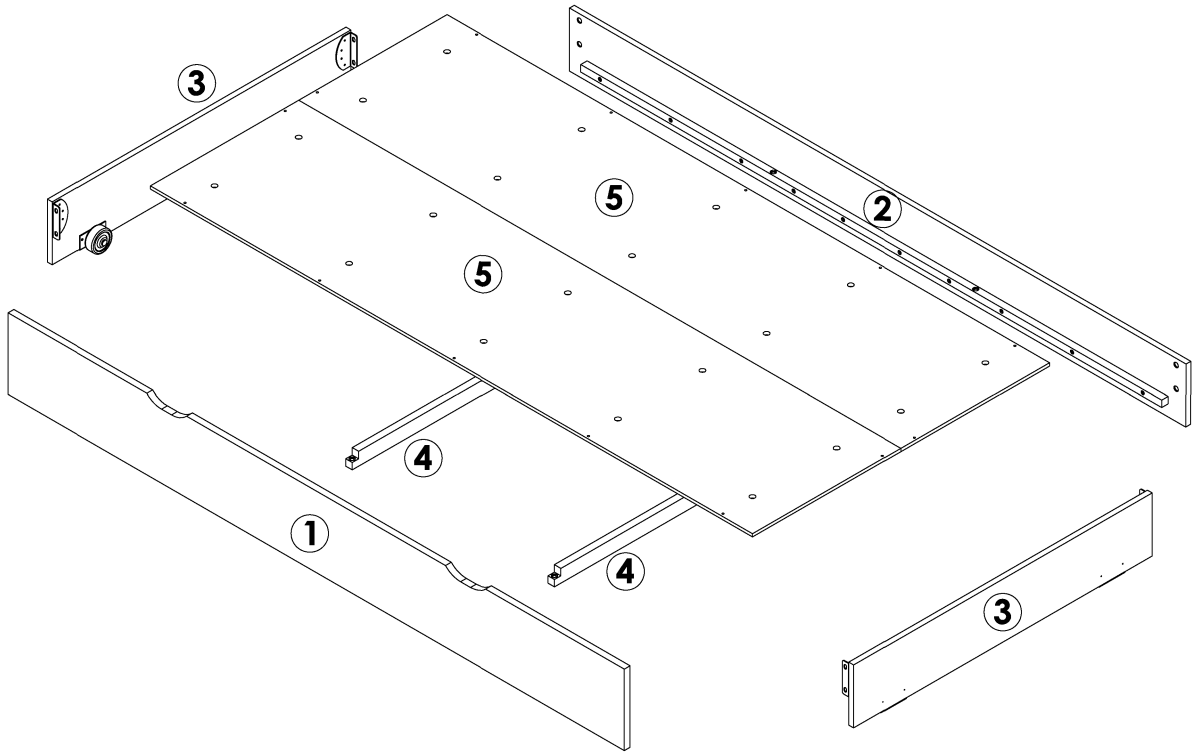

Hardware

A



JCBB BOLT (M8 x 16MM)
8 PCS

B

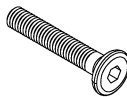

JCBC BOLT (M6 x 35MM)
4 PCS

C



CSK C/B (M4 x 20MM)
14 PCS

D

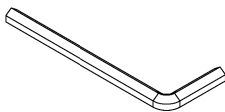

ALLEN KEY (M4 x 60MM)
1 PC

E

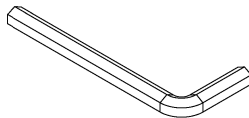

ALLEN KEY (M5 x 60MM)
1 PC

STEP 1

DO NOT use any power tools as this may damage the bed frame and will invalidate any claim.

Attach and Secure **Front Panel** and **Rear Panel** onto **Side Panel** by using **(A)**, tighten it up by using **(E)**.

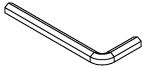
A		8
E		1

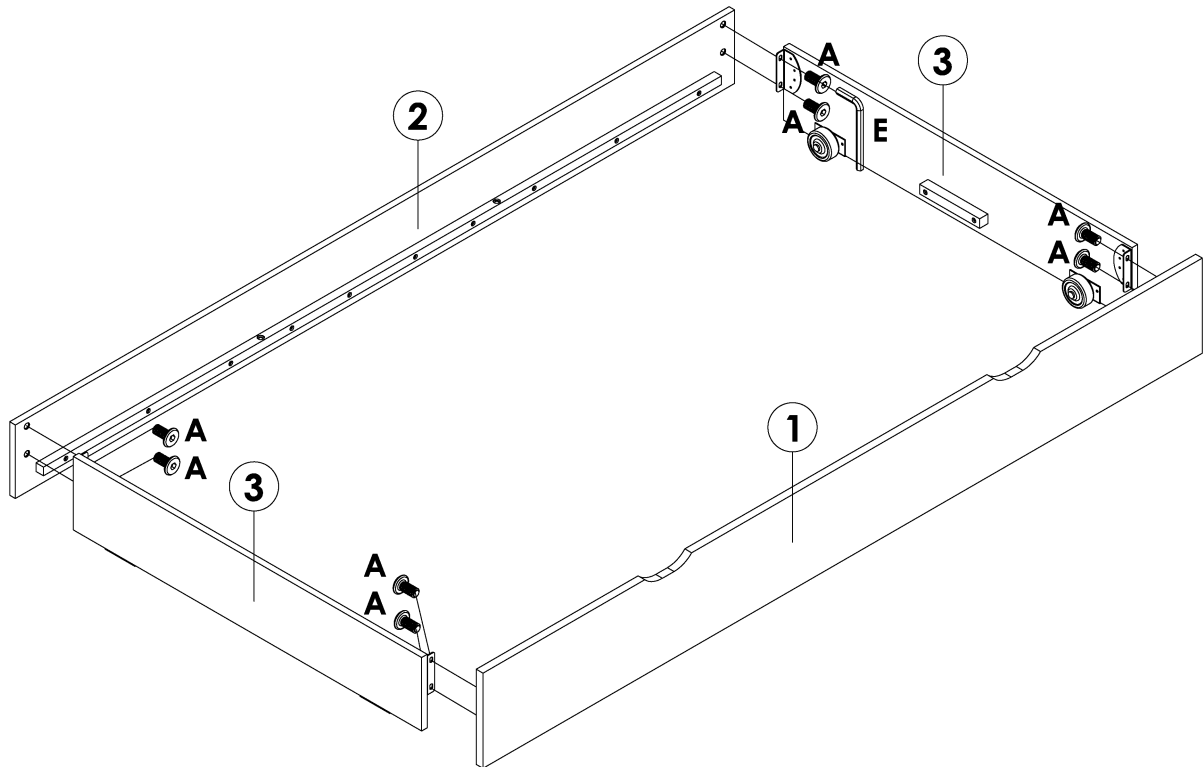

STEP 2

DO NOT use any power tools as this may damage the bed frame and will invalidate any claim.

Place both **Base Support** accurately beneath both $\varnothing 8\text{MM}$ holes. Insert **(B)** into all $\varnothing 14\text{MM}$ holes on **Front Panel** and **Rear Panel**, tighten it up by using **(D)**.

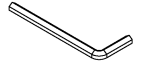
B		4
D		1

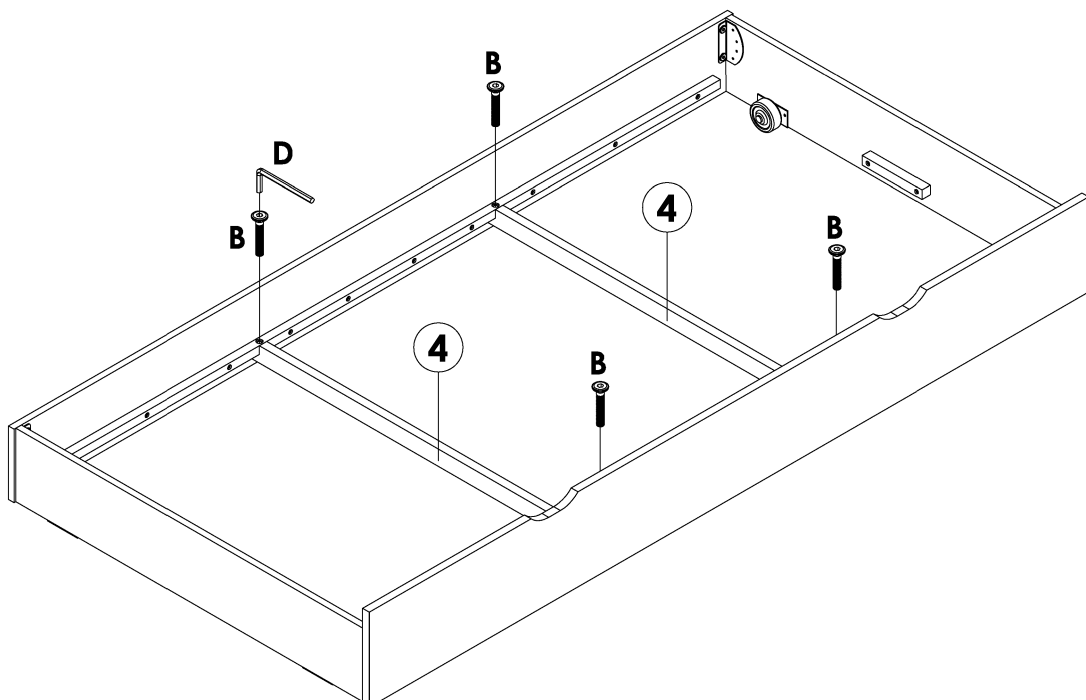

STEP 3

DO NOT use any power tools as this may damage the bed frame and will invalidate any claim.

Lay down the first piece of **Base Panel** onto previous assembly, slide it all the way in on your left hand side.

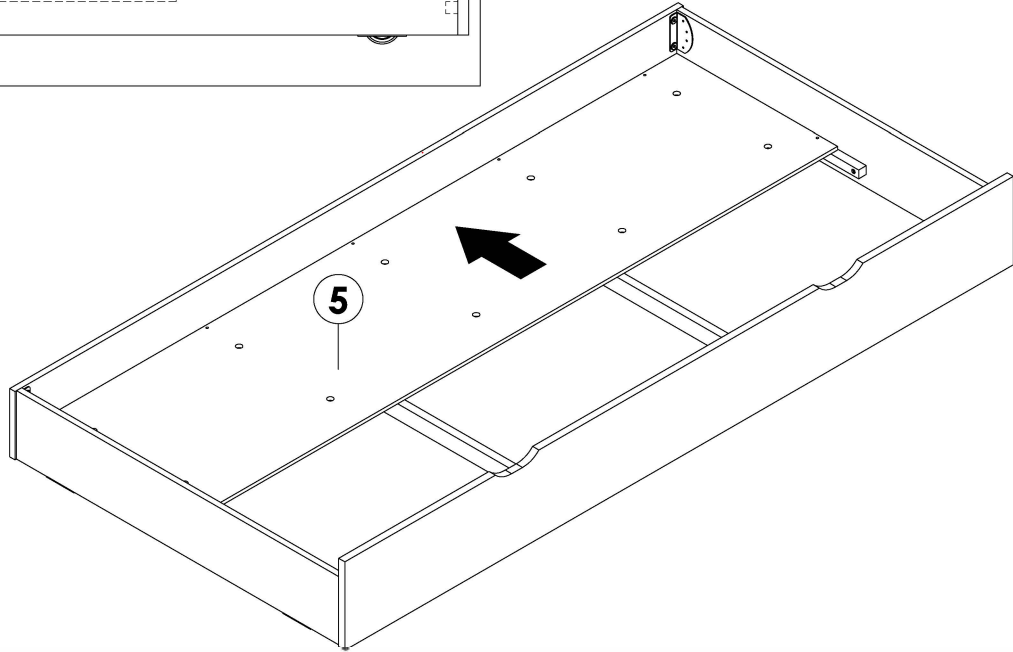
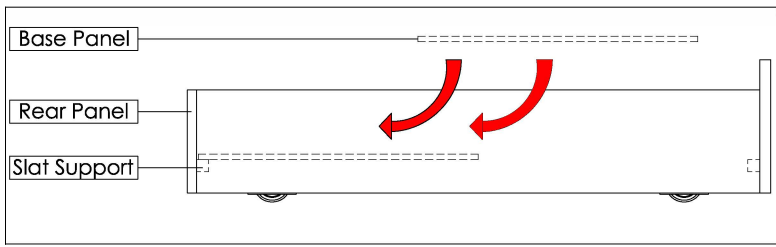

STEP 4

DO NOT use any power tools as this may damage the bed frame and will invalidate any claim.

Lay down the Second piece of **Base Panel** onto previous assembly, slide it all the way in on your right hand side.

Your **Oliver Bunk/Triple Trundle** is now ready to use.

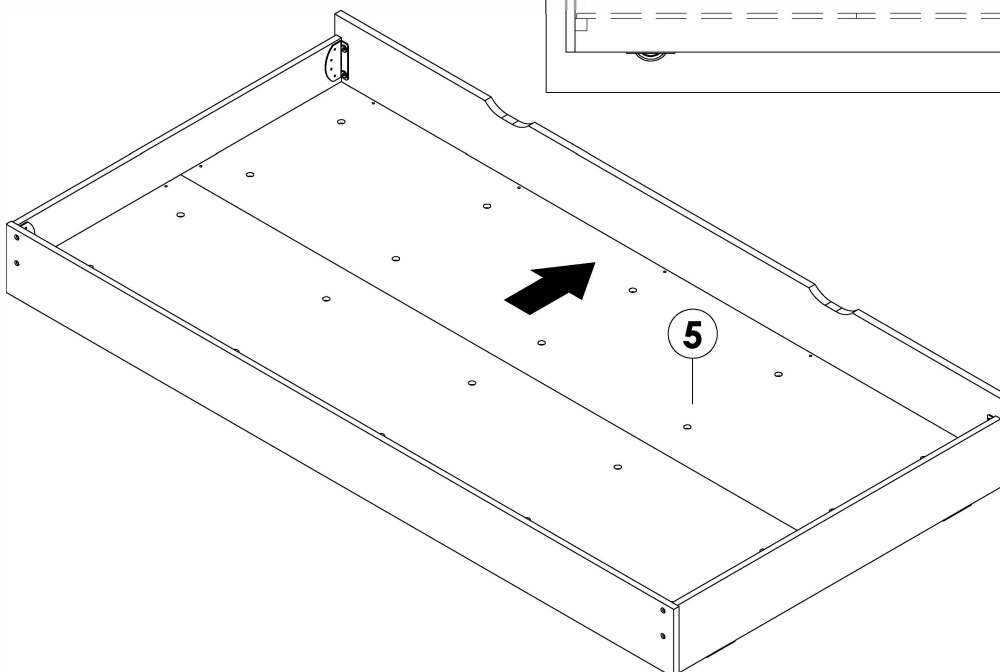
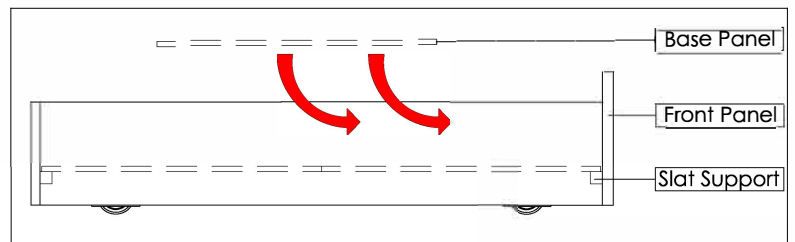

STEP 5

DO NOT use any power tools as this may damage the bed frame and will invalidate any claim.

C



14

Insert **(C)** into Ø5MM Holes on **Base Panel**, tighten it up by using crosshead screw driver.

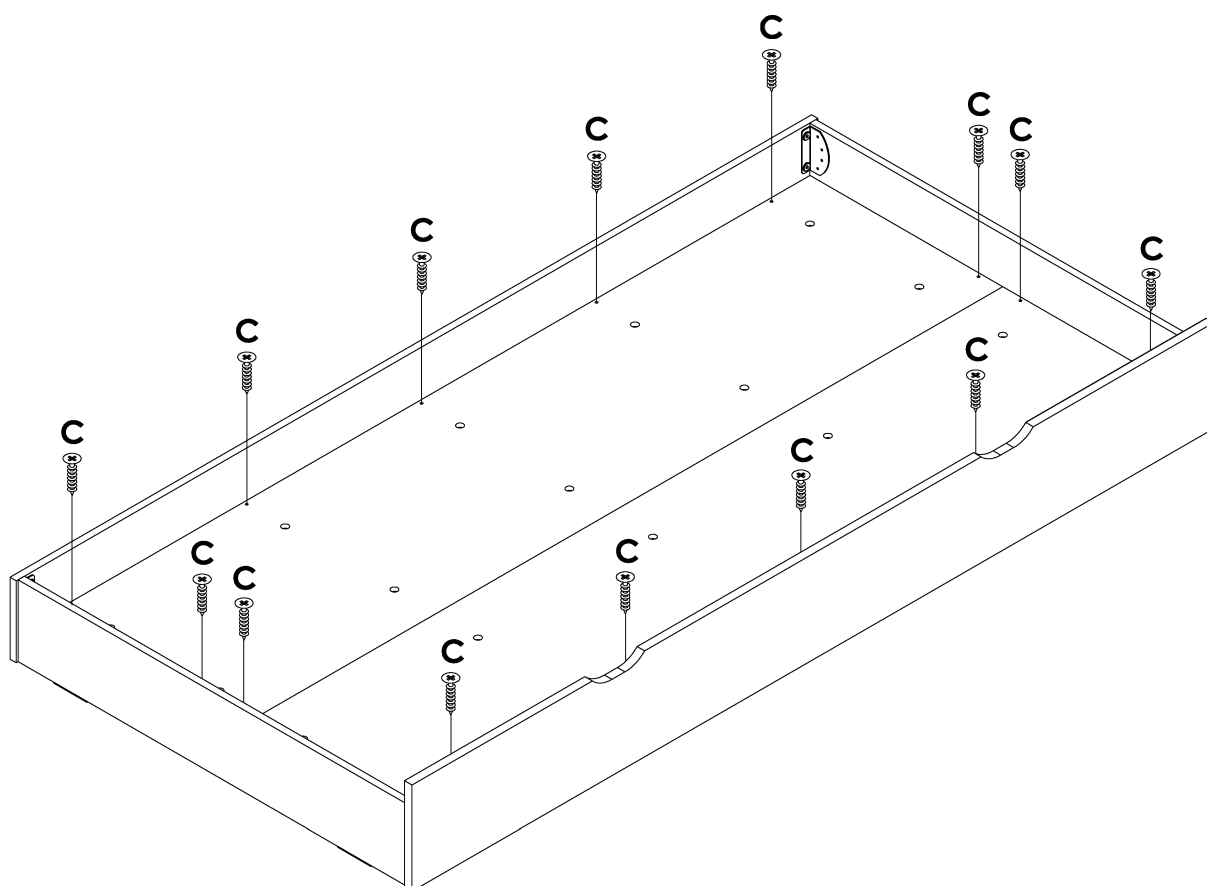

Your **Oliver Trundle** is now complete ready to use.

Oliver Triple

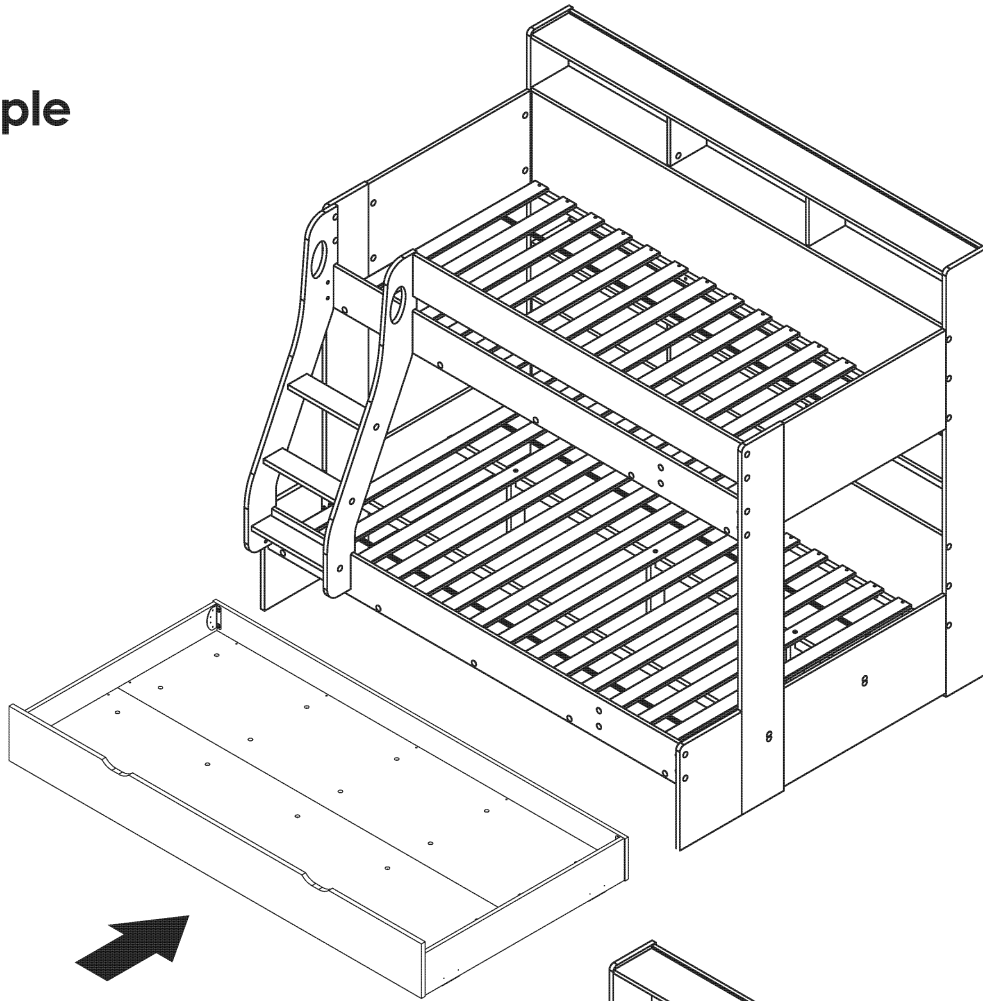

Oliver Bunk

