

Millie & Jones.

Assembly Guide

Before Assembly

- Check Parts - Unpack and ensure all parts are included and undamaged.
- Read Instructions - Review the guide fully before starting.
- Prepare the Space - Clear the area and assemble on a soft surface to prevent damage.
- Gather Tools - Use only the recommended tools.
- Get Help - Larger items may require two people.

Health & Safety

- Keep Kids & Pets Away - Ensure a safe workspace.
- Lift Safely - Avoid strain; lift with care or get assistance.
- Wear Protection - Gloves help prevent injuries.
- Secure Loose Clothing - Avoid anything that could get caught.
- Handle Small Parts Carefully - Keep screws and fittings away from children.
- Dispose of Packaging Safely - Recycle and keep plastic bags out of reach.

ASSEMBLY INSTRUCTION

A	Arm A1 A2	2 pcs
B	Back Panel	1 pc
C	997mm Slat 13 Pcs	1 pc
D	Front Side Rail (PU)	1 pc
E	Back Side Rail	1 pc
F	Trundle Front Panel (PU)	1 pc
G	1898mm Slat 7 Pcs	1 pc
H	760mm Side Rail Support Rail 997mm Center Slat	2 pcs
I	997mm Center Slat	3 pcs

Step 1 : Attach side rail (D) & (E) to arm (A) by pushing the bracket down to fit it.

Step 2 : Attach the Back Panel (B) to the arm (A) as shown.

BACK VIEW

Packing Hardware		
1	M5 x 70mm	1 pc
2	M4 x 65mm	1 pc
3	CSK M4 x 32mm	52 pcs
4	CSK M4 x 16mm	24 pcs
5	JCBB M6 X 35	17 pcs
6	JCBB M6 X 50	4 pcs
7	SPRING WASHER	21 pcs
8	FLAT WASHER	21 pcs
9	Roller	6 pcs
10	JCBB M8 X 20	8 pcs

Step 3 : Tighten the 4 Corner with Allen Key (1). Install the slats to side rail. Tighten the slats with CSK screw (3). The distance of the slats should be sufficient to obtain desirable bed stability.

Step 4 : Attach the Center Slat (I) to the slat (G).

Step 5 : Affix the roller (9) to the Center slat (1) follow the marking on the Center slat (1).

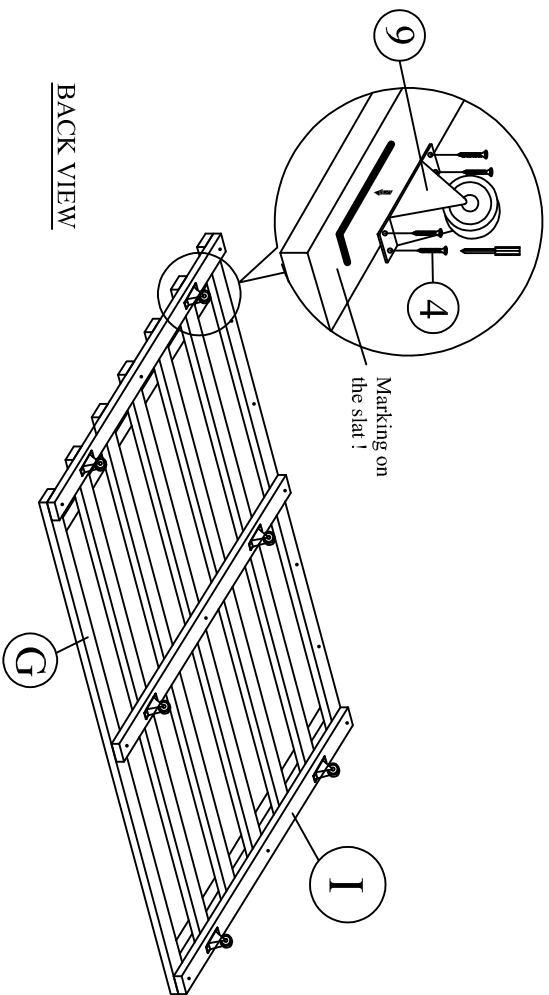

Step 6 : Attach side rail support rail (H) to trundle front panel (F).

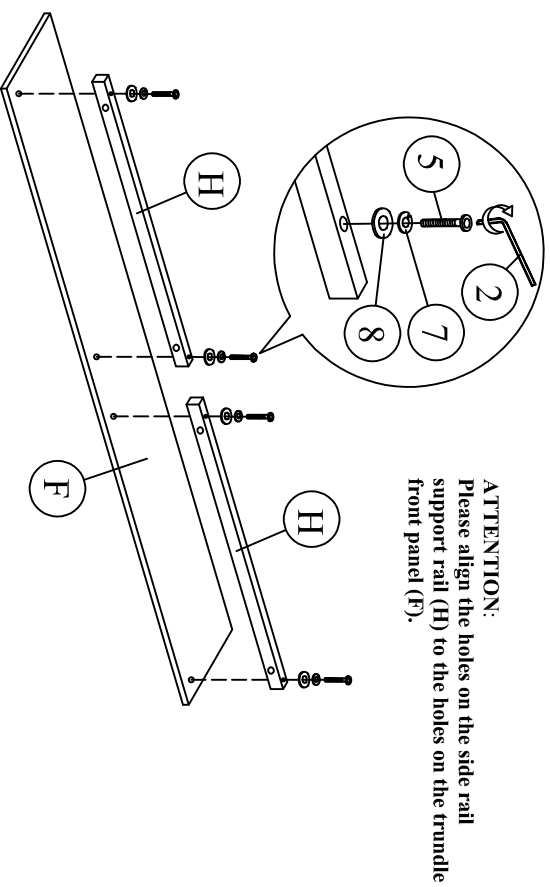

Step 7 : Attach the slat (G) to the trundle front panel (F).

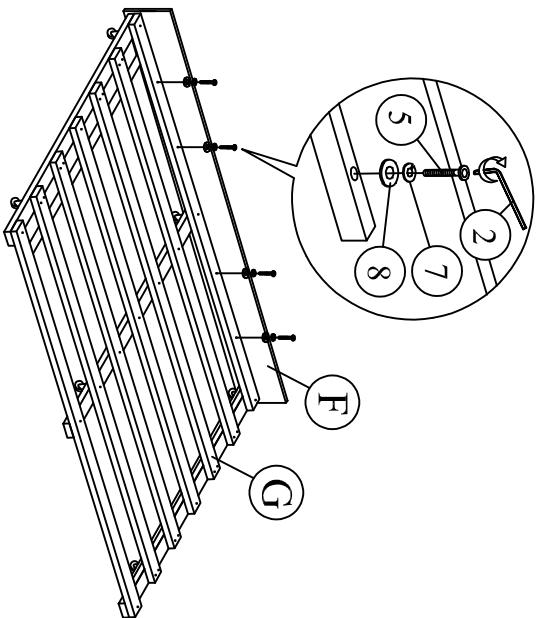

Step 8 : Tighten the slat (G) with CSK screw (3).

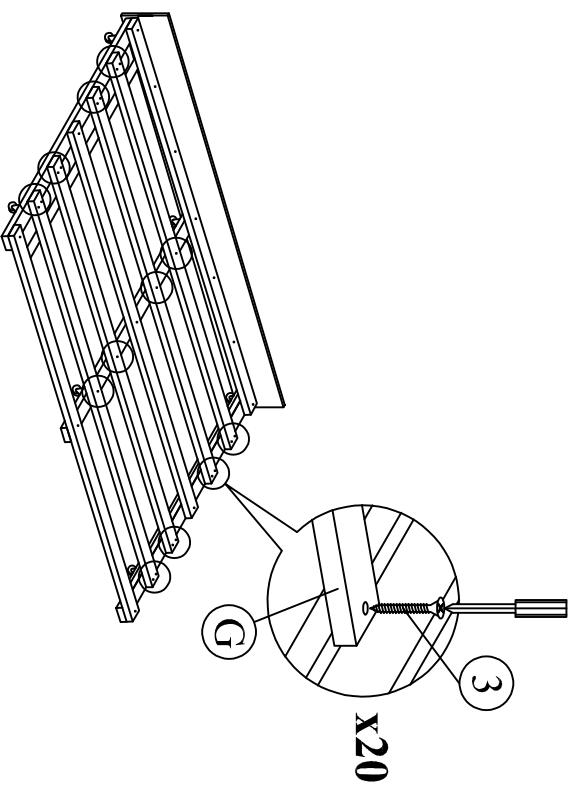

Step 9 : Assembly is complete.

