

# 2374TOBO

PARISOT INDUSTRIE 70800 SAINT LOUP SUR SEMOUSE -FRANCE-

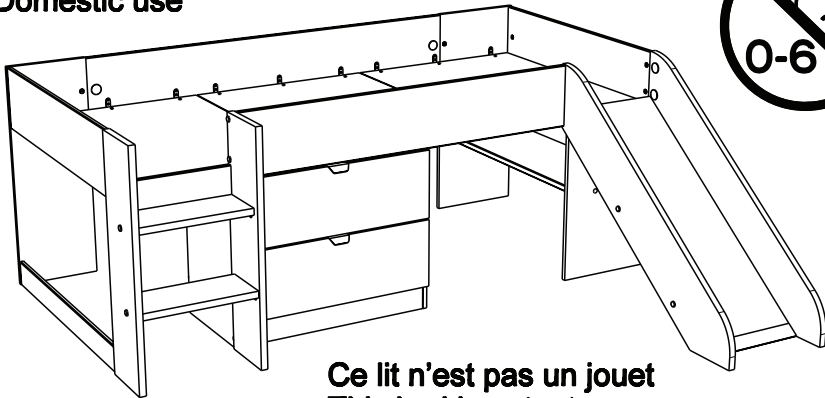

Usage domestique  
Domestic use



Ce lit n'est pas un jouet  
This bed is not a toy

## IMPORTANT KEEP FUTURE REFERENCE

WARNING: NOT SUITABLE FOR CHILDREN UNDER 6 YEARS.  
WARNING: DO NOT PLACE THIS CHILD'S BED NEAR HEAT SOURCES,  
WINDOWS AND OTHER FURNITURE.  
WARNING: DO NOT USE THIS CHILD'S BED IF ANY PART IS BROKEN,  
TORN OR MISSING.

## IMPORTANT : CONSERVER CETTE NOTICE POUR UTILISATION FUTURE

ATTENTION ! NE PAS UTILISER POUR ENFANTS DE MOINS DE 6 ANS.  
ATTENTION ! NE PAS PLACER CE LIT ENFANT PRES DE SOURCES DE  
CHALEUR, DE FENETRES ET D'AUTRES MEUBLES.  
ATTENTION ! NE PAS UTILISER CE LIT POUR ENFANT SI UNE PIECE EST  
CASSEE, DECHIREE OU MANQUANTE.

12209000

Gamme : TOBO

PARISOT INDUSTRIE

## FR Remerciements :

Nous vous remercions d'avoir choisi un meuble créé et fabriqué par le Groupe Parisot et espérons qu'il vous donnera entière satisfaction.

## EN Thanks:

Thank you for choosing furniture designed and manufactured by the Parisot Group. We hope you are totally satisfied with your purchase.

## DE Danksagung:

Wir danken Ihnen für den Kauf eines Frankreich von der Parisot-Gruppe entworfenen und hergestellten Möbelstücks und hoffen, dass Sie es zu Ihrer vollkommenen Zufriedenheit finden werden.

## HU Köszönet:

Köszönjük, hogy a Parisot Groupe által létrehozott és gyártott bútort választott, reméljük, hogy elégedett lesz a termékkel.

## PT Agradecimentos:

Obrigado por ter escolhido um móvel concebido e fabricado pelo Grupo Parisot, esperando que seja do seu inteiro agrado.

## IT Ringraziamenti:

Grazie per avere scelto un mobile progettato e fabbricato dal Gruppo Parisot. Speriamo soddisfisi appieno le vostre esigenze.

## NL Bedankje:

Wij bedanken u voor de aankoop van een door de Groep Parisot ontworpen en vervaardigd meubel en hopen dat u er veel plezier aan zult beleven.

## CZ Poděkování:

Děkujeme, že jste si vybrali nábytek navržený a vyrobený společností Parisot Group. Doufáme, že budete svým nákupem naprosto spokojeni.

## ES Agradecimientos:

Les damos las gracias por haber elegido un mueble diseñado y fabricado por el Groupe Parisot y esperamos que sea de su total agrado.

## PL Podziękowania:

Dziękujemy za wybór mebli stworzonych i wyprodukowanych przez Grupę Parisot. Mamy nadzieję, że będziecie Państwo w pełni zadowoleni z zakupu.

## SK Pod'akovanie:

Ďakujeme, že ste si vybrali nábytok navrhnutý a vyrobený spoločnosťou Parisot Group. Dúfame, že budete svojim nákupom absolútne spokojní.

## AR شكر:

نشكركم لاختياركم هذه القطعة من الأثاث من تصميم وتصنيع مجموعة باريسو Parisot ونتمنى أن تظل رضاءكم.

**FR**

Donnez ou recyclez vos meubles.

 ou  ou 

Association Magasin Déchèterie

<https://quefairedemesdechets.fr>

**Serrer correctement les éléments de fixation avec l'outillage fourni ou préconisé.**  
**Tighten the fasteners correctly with the tools provided or recommended.**

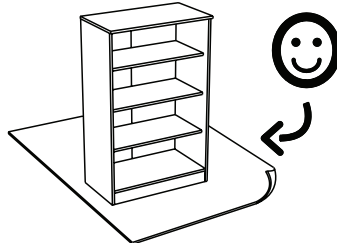
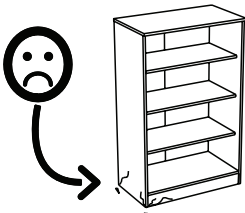
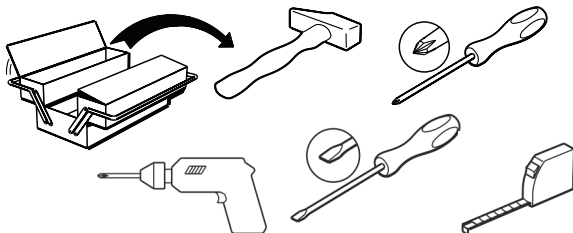
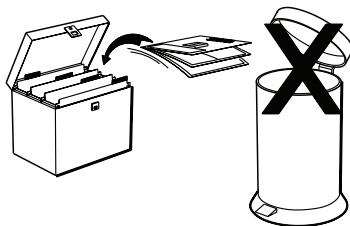

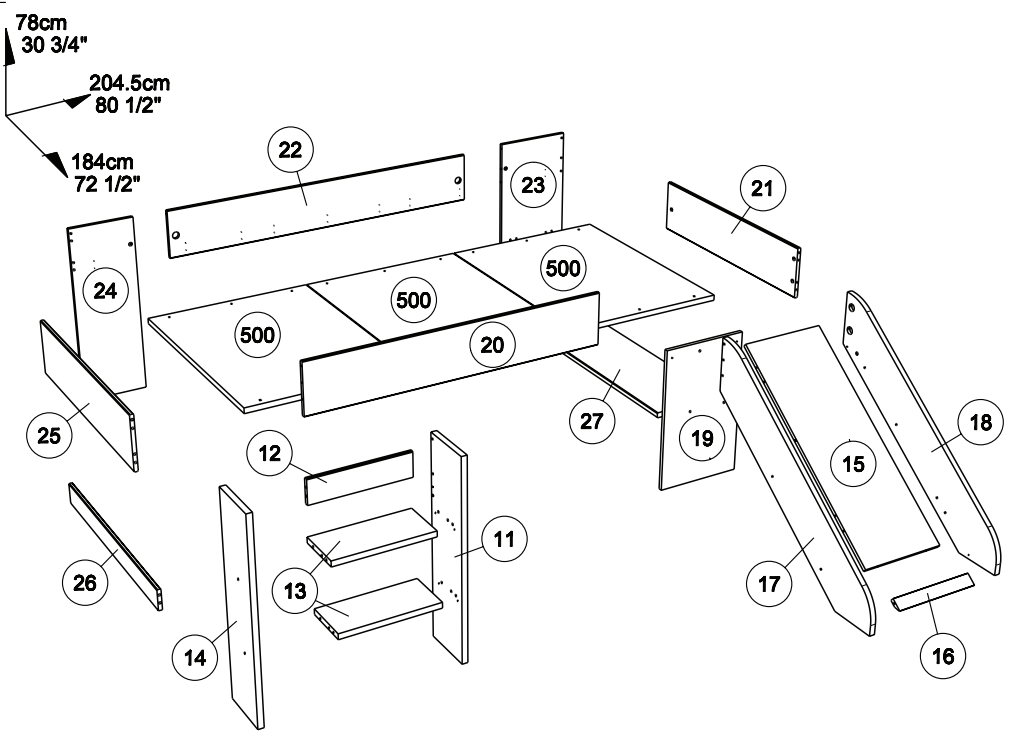

		mm			inch		
16	x 1	350	50	16	13 3/4	1 15/16	5/8
12	x 1	380	95	15	14 15/16	3 3/4	9/16
13	x 2	380	174	22	14 15/16	6 7/8	7/8
19	x 1	595	350	15	23 7/16	13 3/4	9/16
11	x 1	780	200	22	30 11/16	7 7/8	7/8
14	x 1	780	200	22	30 11/16	7 7/8	7/8
24	x 1	780	280	15	30 11/16	11	9/16
23	x 1	780	328	15	30 11/16	12 15/16	9/16
500	x 3	890	661	22	35 1/16	26	7/8
26	x 1	898	85	15	35 3/8	3 3/8	9/16
25	x 1	898	215	15	35 3/8	8 7/16	9/16
21	x 1	898	215	15	35 3/8	8 7/16	9/16
27	x 1	900	305	22	35 7/16	12	7/8
15	x 1	967	350	15	38 1/16	13 3/4	9/16
18	x 1	1208	212	22	47 9/16	8 3/8	7/8
17	x 1	1208	212	22	47 9/16	8 3/8	7/8
20	x 1	1225	215	15	48 1/4	8 7/16	9/16
22	x 1	1427	215	15	56 3/16	8 7/16	9/16

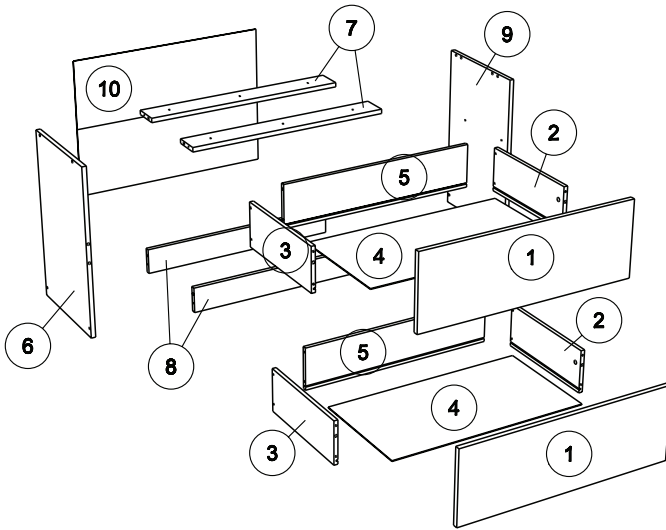

		mm			inch		
⑨	x 1	574	360	15	22 5/8	14 3/16	9/16
⑥	x 1	574	360	15	22 5/8	14 3/16	9/16
⑦	x 2	678	86	15	26 11/16	3 3/8	9/16
⑧	x 2	678	86	15	26 11/16	3 3/8	9/16
①	x 2	685	235	15	26 15/16	9 1/4	9/16
②	x 2	350	138	13	13 3/4	5 7/16	1/2
③	x 2	350	138	13	13 3/4	5 7/16	1/2
⑤	x 2	628	138	13	24 3/4	5 7/16	1/2
④	x 2	640	349	3	25 3/16	13 3/4	1/8
⑩	x 1	706	500	3	27 13/16	19 11/16	1/8



**Tenir éloigné les jeunes enfants lors de l'assemblage. Présence de petites pièces susceptibles d'être ingérées.**  
**Keep young children away during assembly. Presence of small parts that may be ingested.**

**Vérifier la présence et l'état de la quincaillerie et des pièces avant de débuter le montage.**  
**Check the presence and condition of the hardware and parts before starting assembly.**

**Ne pas monter ou utiliser le mobilier si certains éléments sont cassés, endommagés ou manquants, et n'utiliser que des pièces détachées approuvées par le fabricant.**  
**Do not assemble or use the furniture if any parts are broken, damaged or missing, and only use spare parts approved by the manufacturer.**

**Un mauvais montage, calage ou manutention peut entraîner une fragilisation des assemblages et/ou des pièces.**  
**Incorrect assembly, securing or handling may result in weakened assemblies and / or parts.**

**Il convient que tous les dispositifs d'assemblage soient toujours convenablement serrés et régulièrement vérifiés, et resserrés, si nécessaire.**  
**All assembly devices should always be properly tightened and regularly checked, and re-tightened, if necessary.**

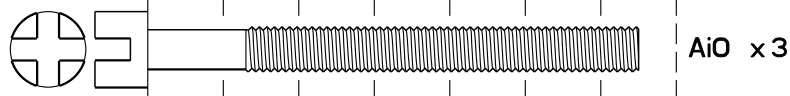
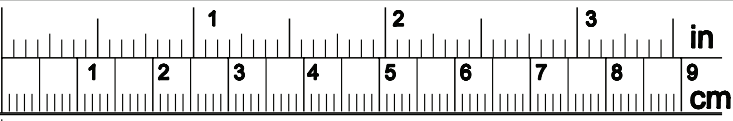

AiO x 3

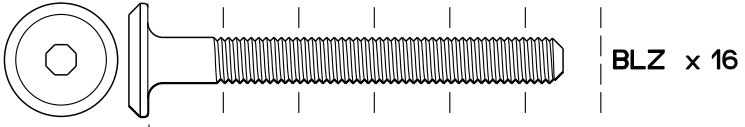

BLZ x 16

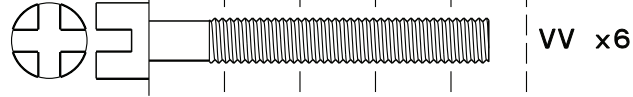

VV x 6

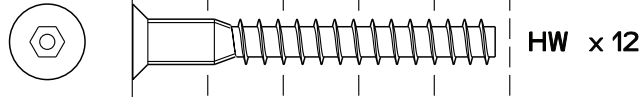

HW x 12

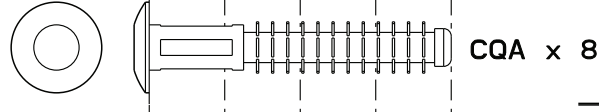

CQA x 8

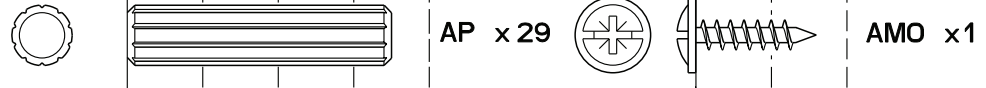
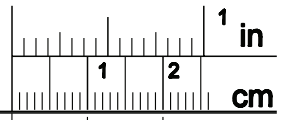

AMO x 1

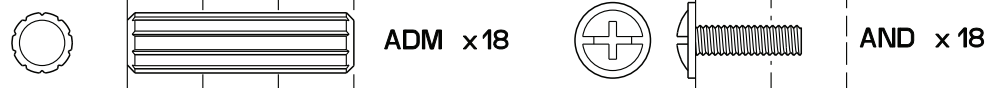

ADM x 18

AND x 18

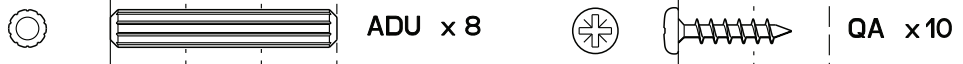

ADU x 8

QA x 10

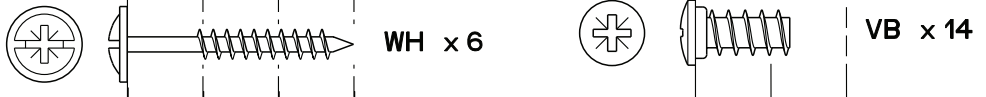

WH x 6

VB x 14

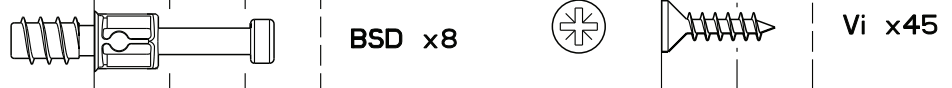

BSD x 8

Vi x 45

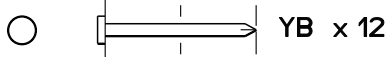

YB x 12

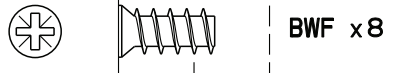

BWF x 8



AKJ x 18

AiA x 2

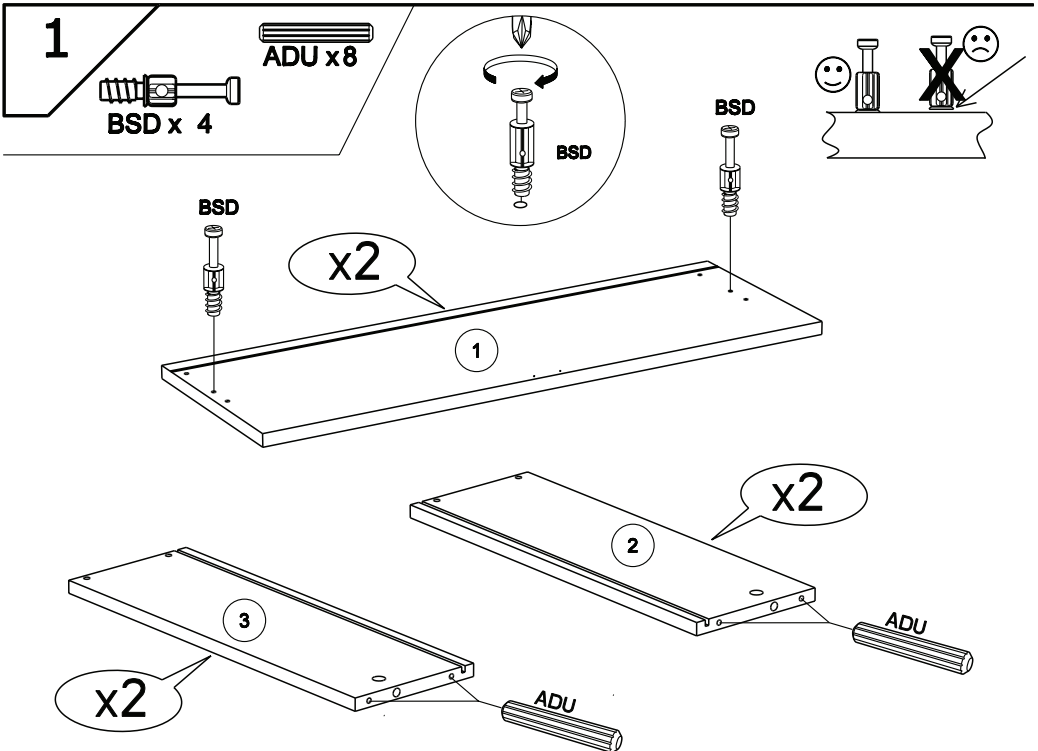
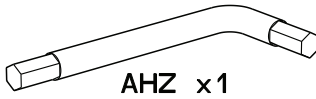
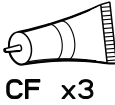
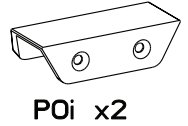
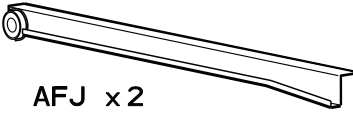
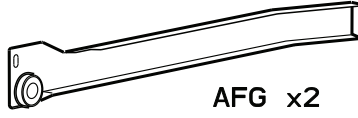
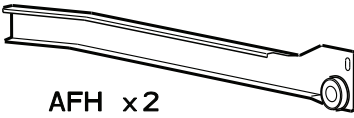
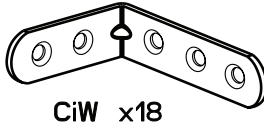
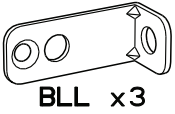
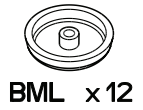
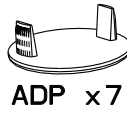
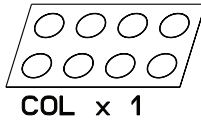
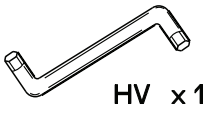

2



BZG x 4

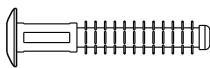

CQA x 8

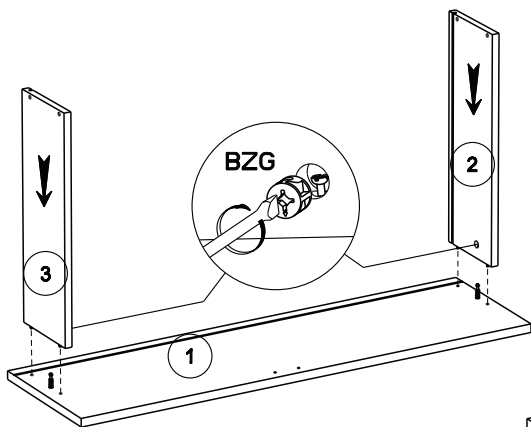

x2

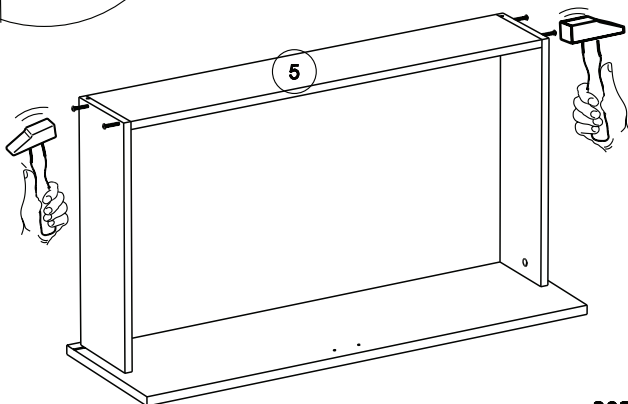
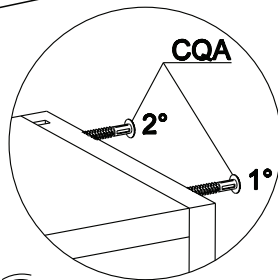
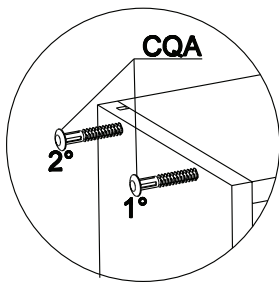
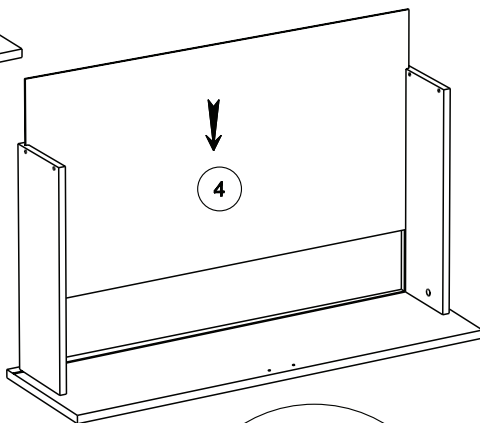

**3**

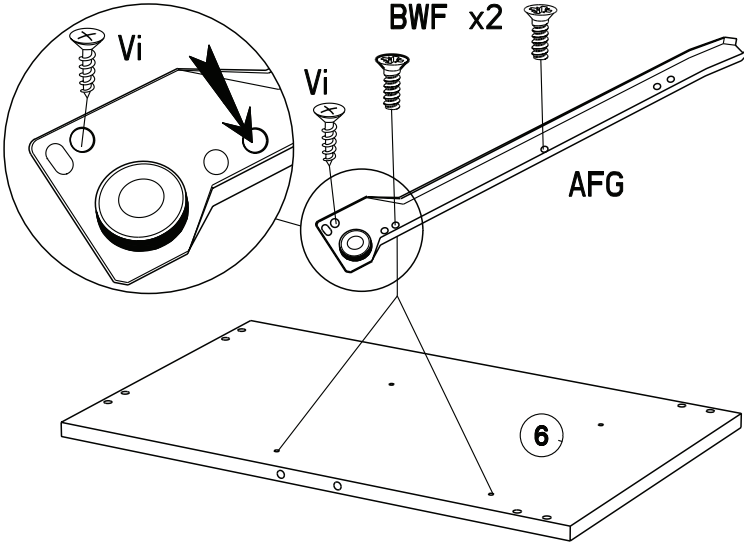

**4**

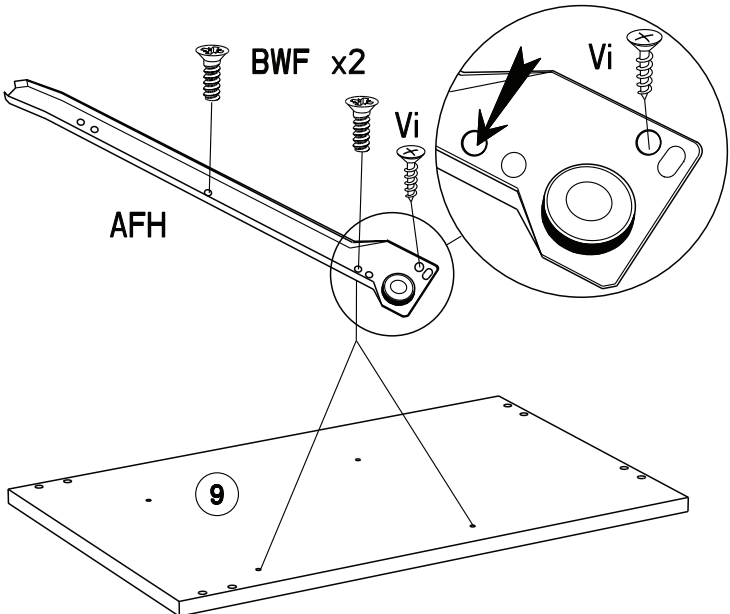
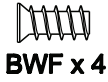





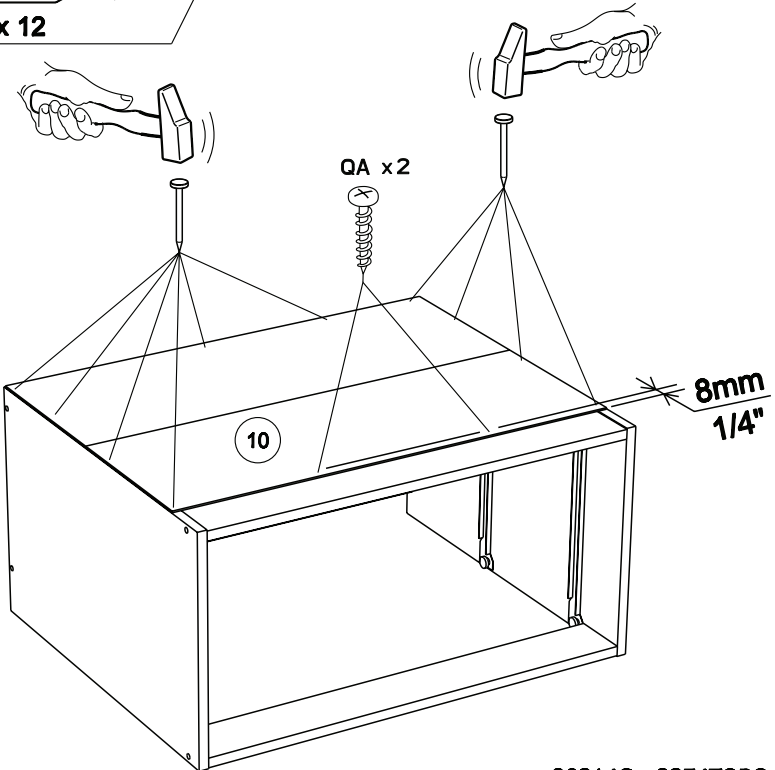
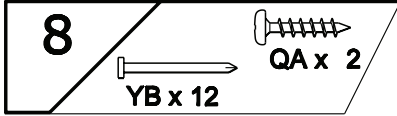
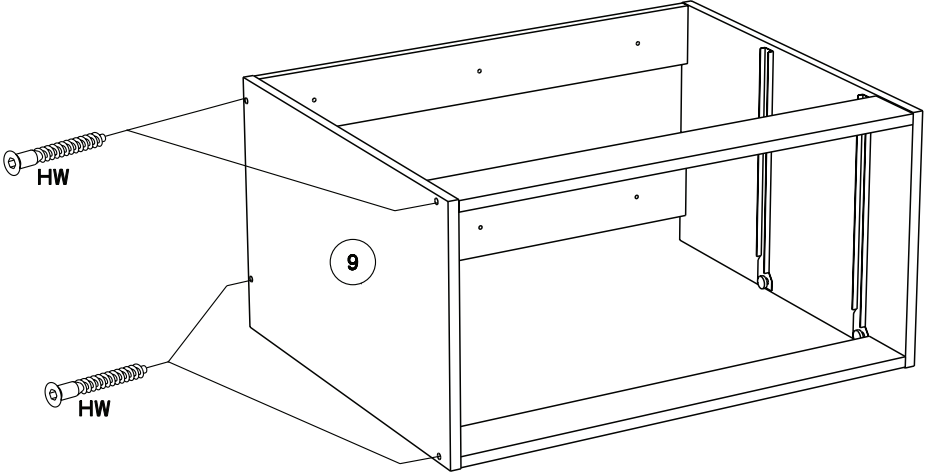
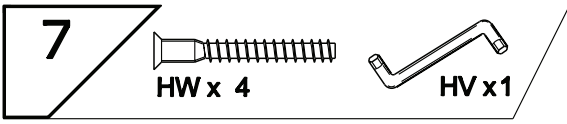

9

  
BSD x 2

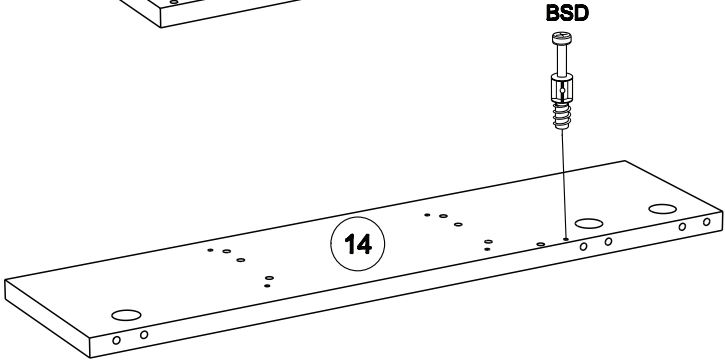
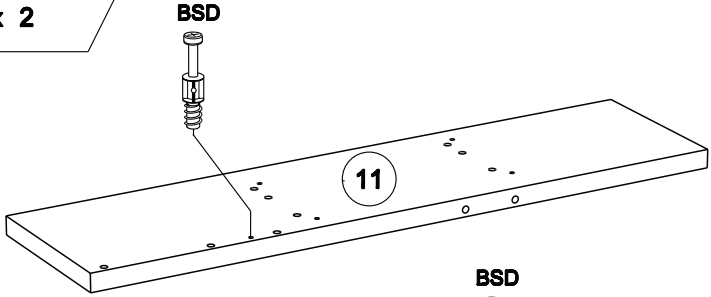

10

  
ADM x 2

  
Vi x 4

  
CiW x 2

  
ADM



~~  
ADM~~

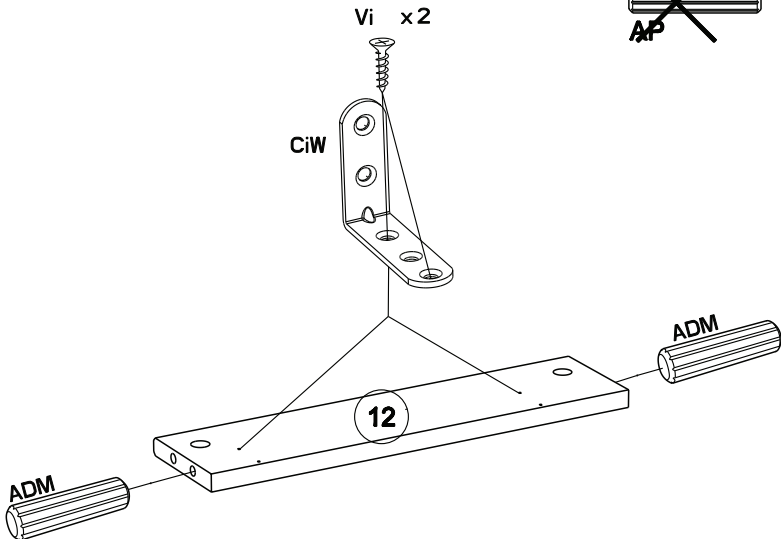

11

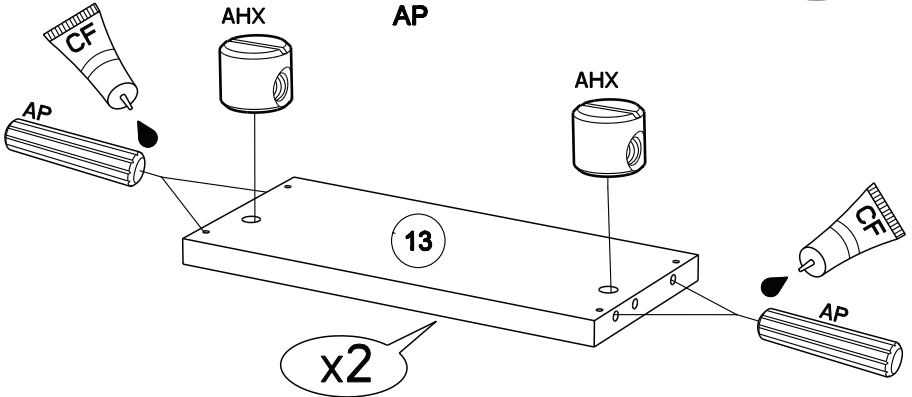
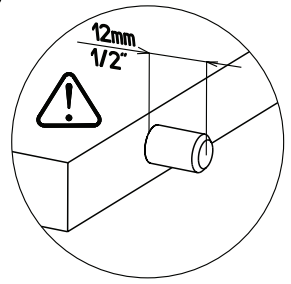

12

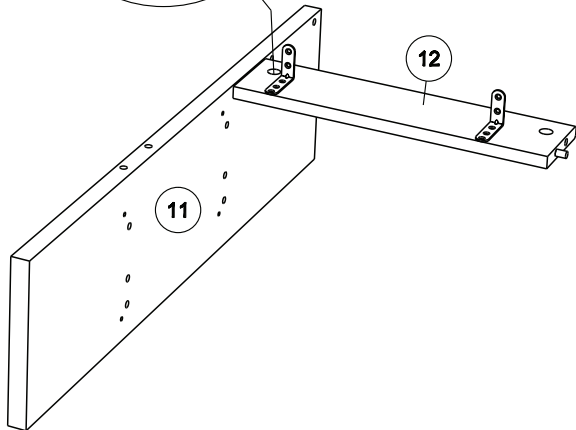
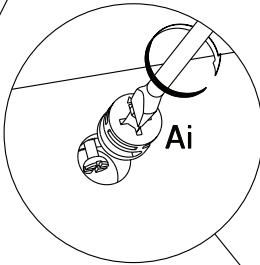

13



BML x 2



BLZ x 2

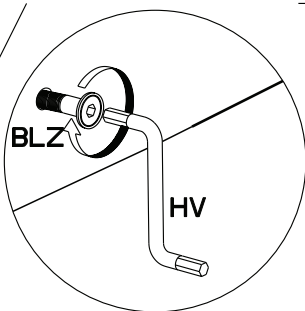

BML

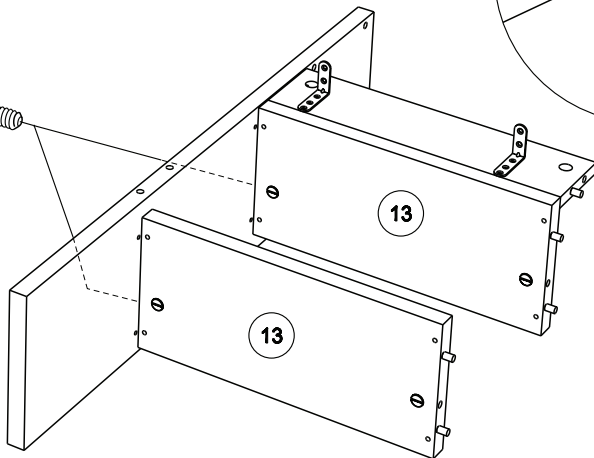
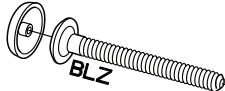

14



BML x 2



BLZ x 2



Ai x1

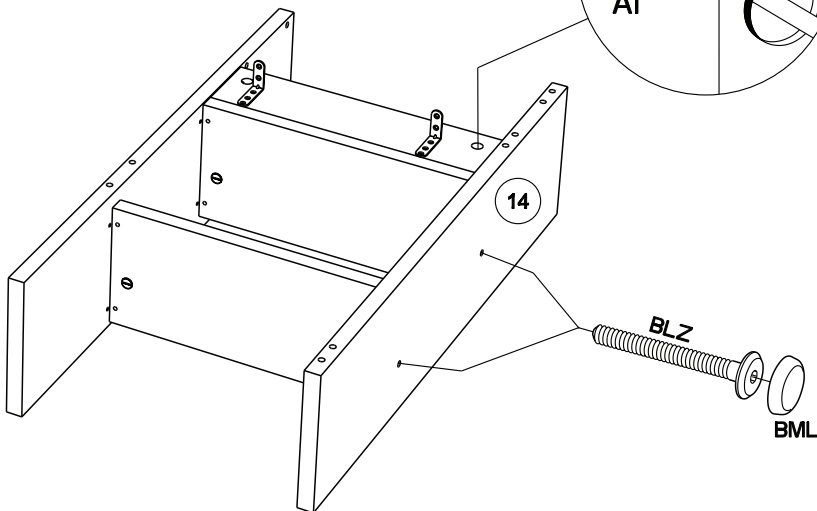
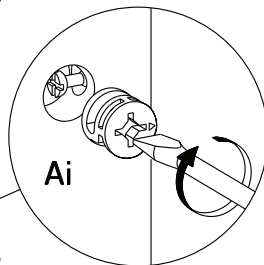

15



BAG x 8

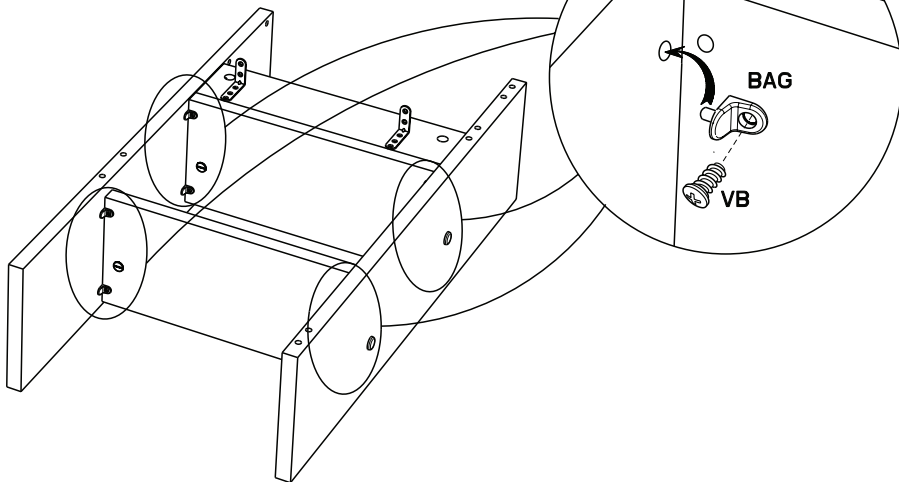

16



ADM x 2



ADM



AP

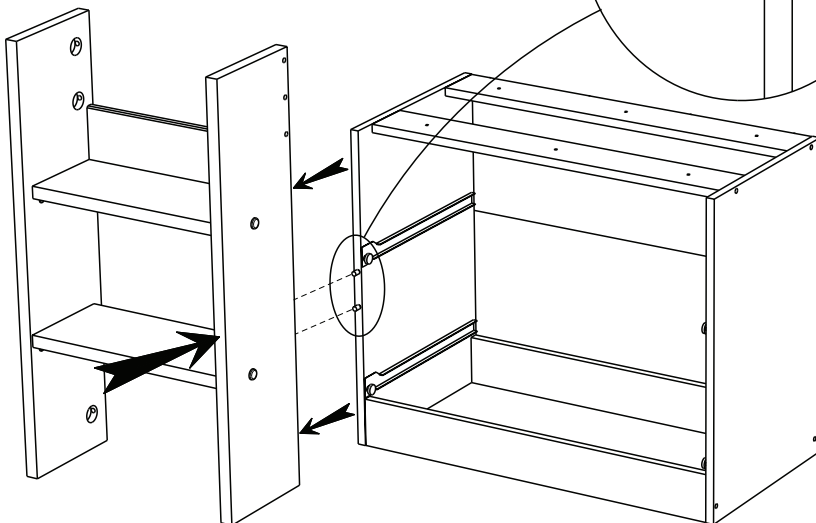
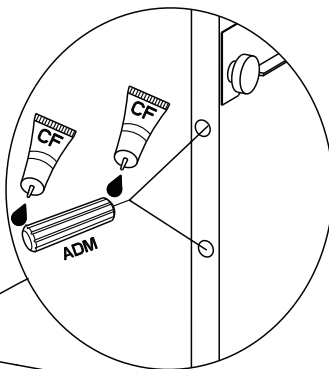

**17**

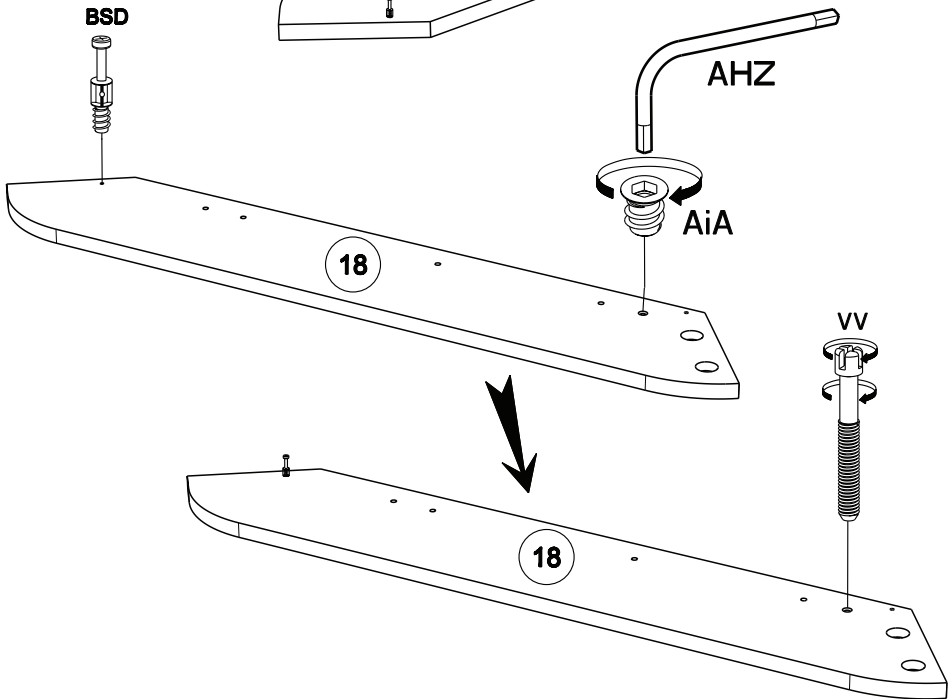
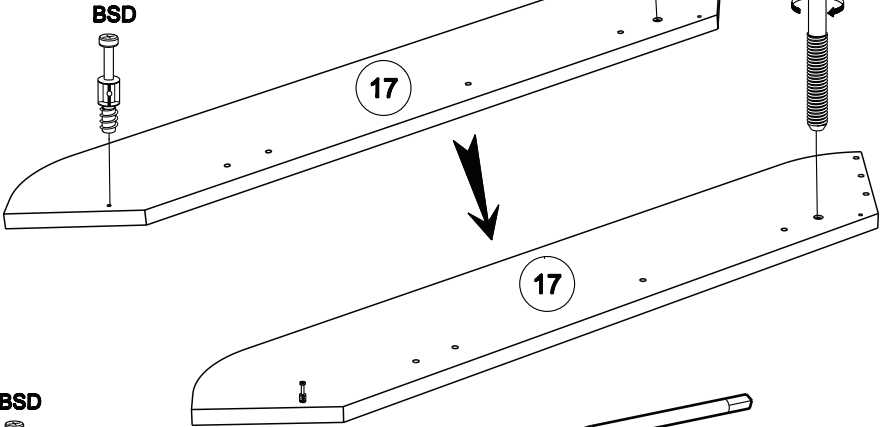
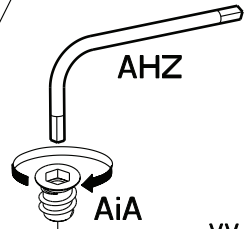
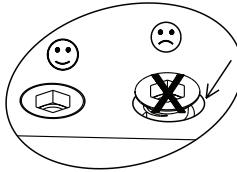
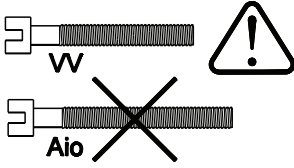
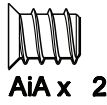
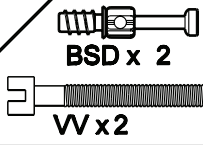

18

ADM x6

CF x1

ADM

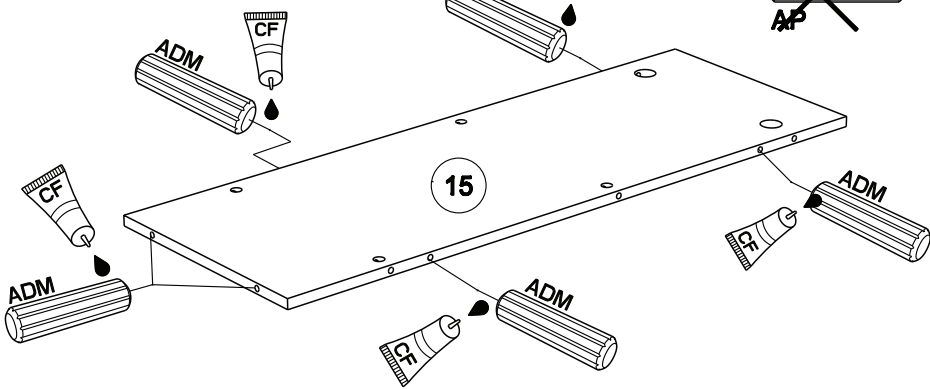

19

CiW x 2

Vi x 4

AP x1

BLL x2

VB x 2

Vi x2

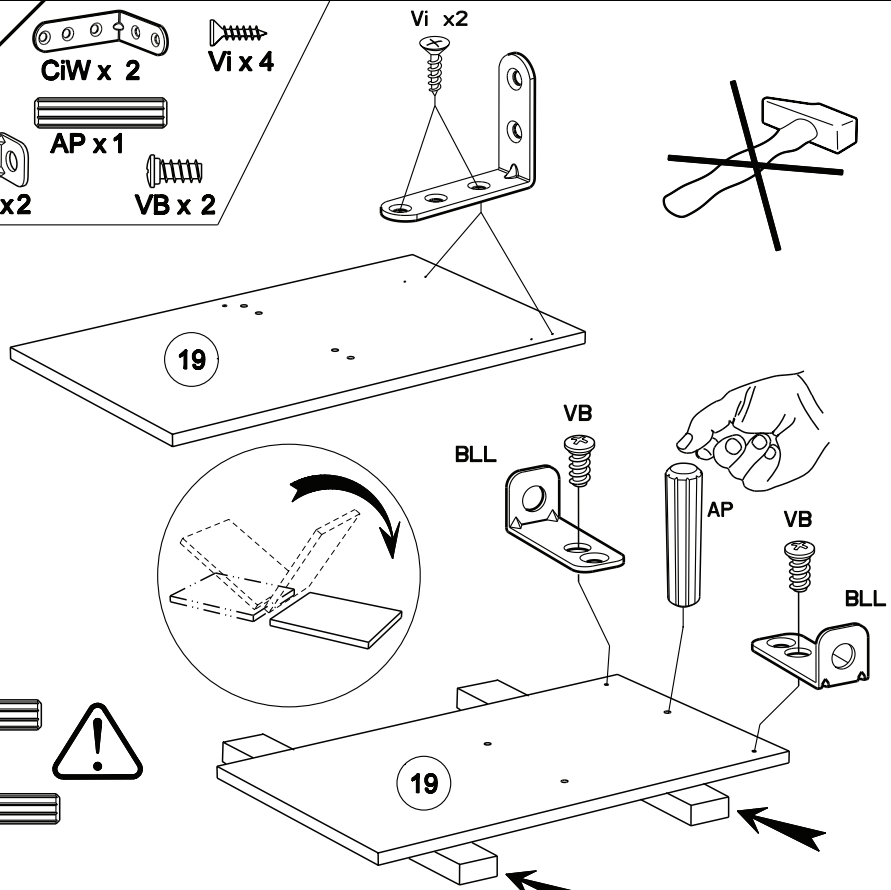
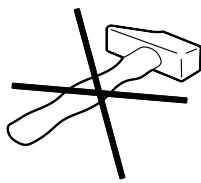

AP



20

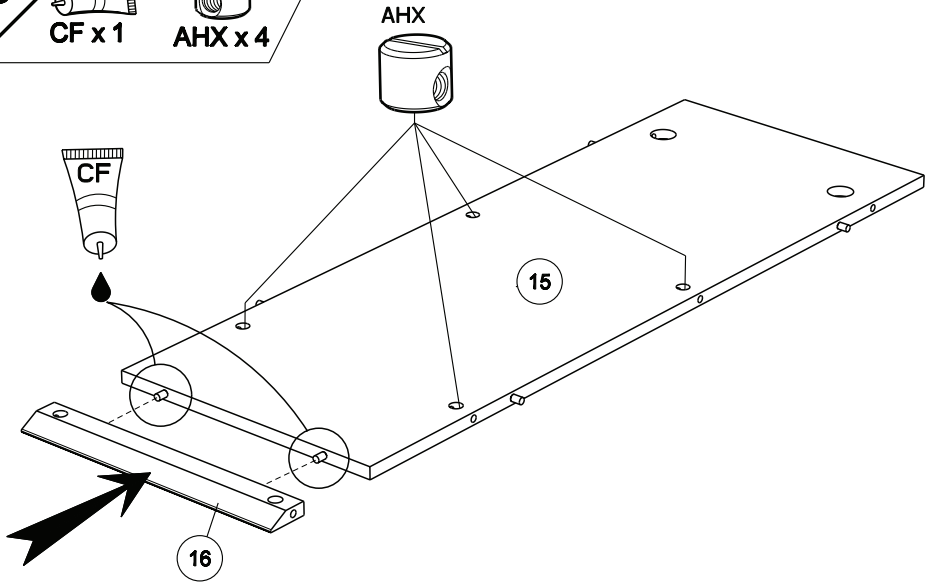

21

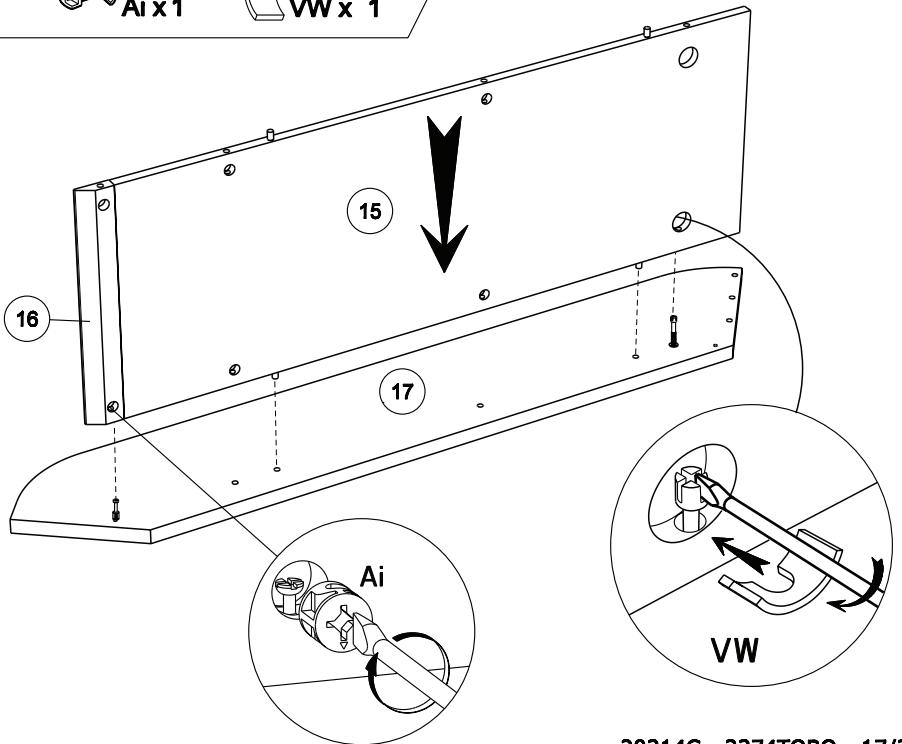

22



VW x 1



Ai x 1

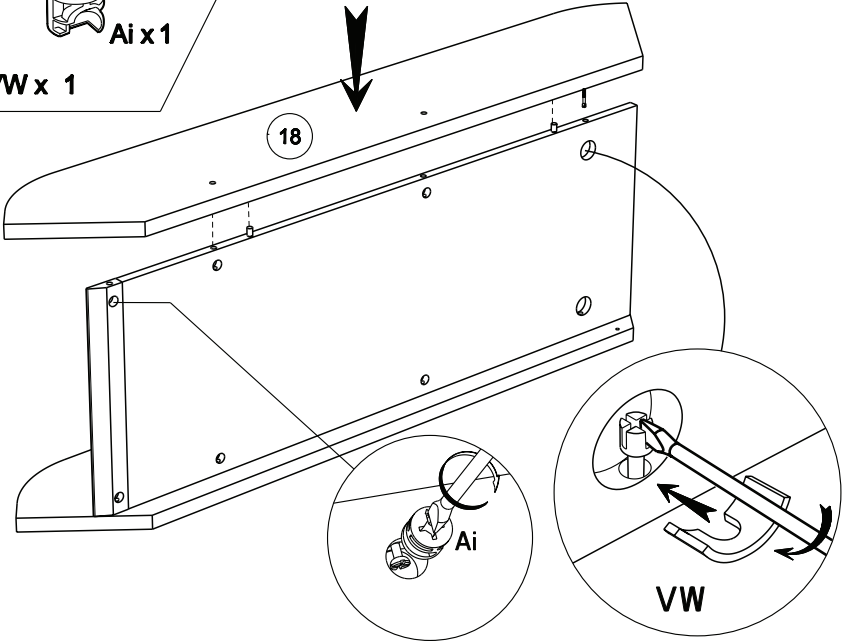

23



BML x 4



BLZ x 4

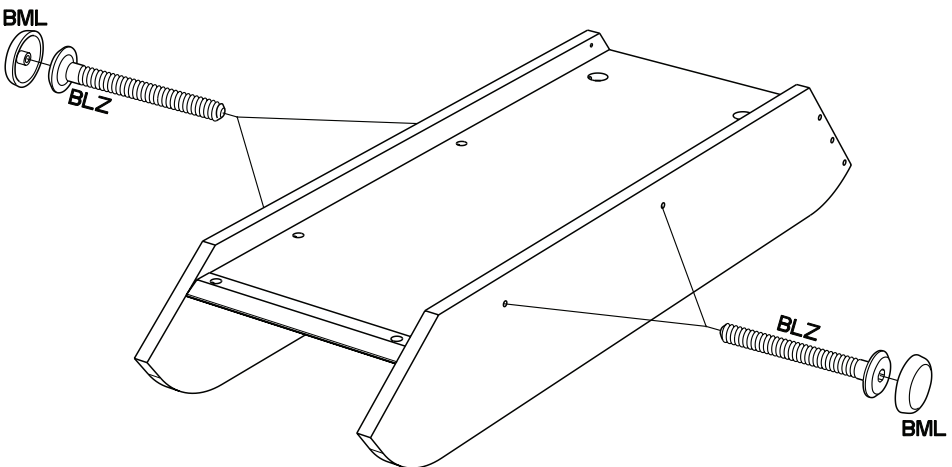

24

  
VB x 2

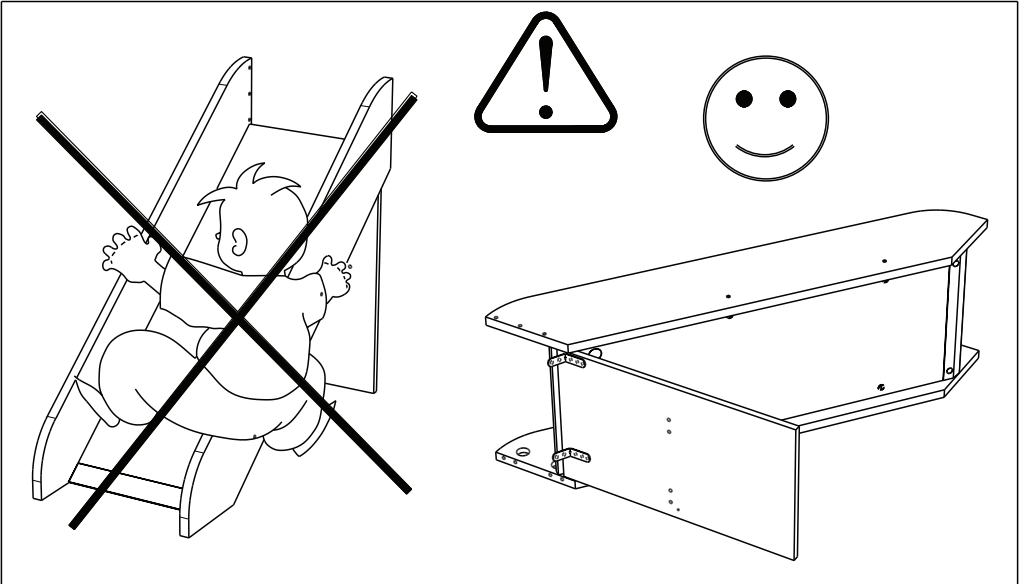
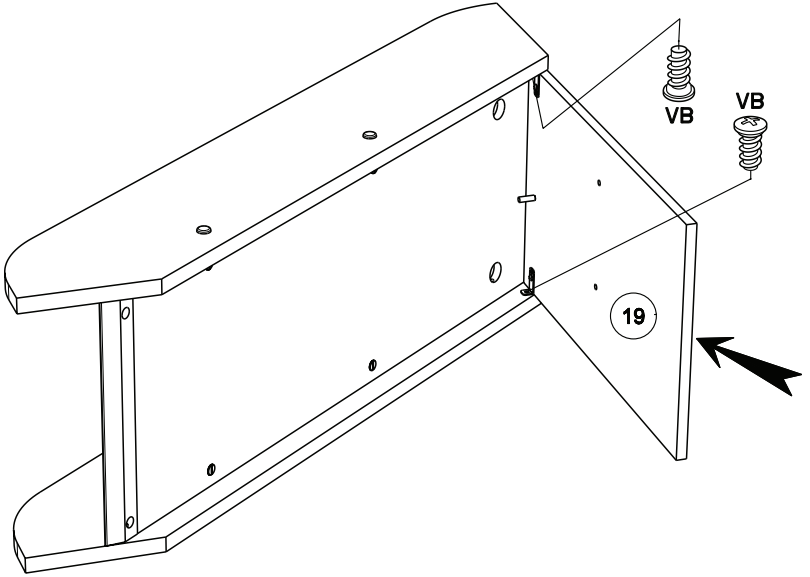

25

Vi x 10

CiW x 5

AHX x 4

AP x 2

CF x 1

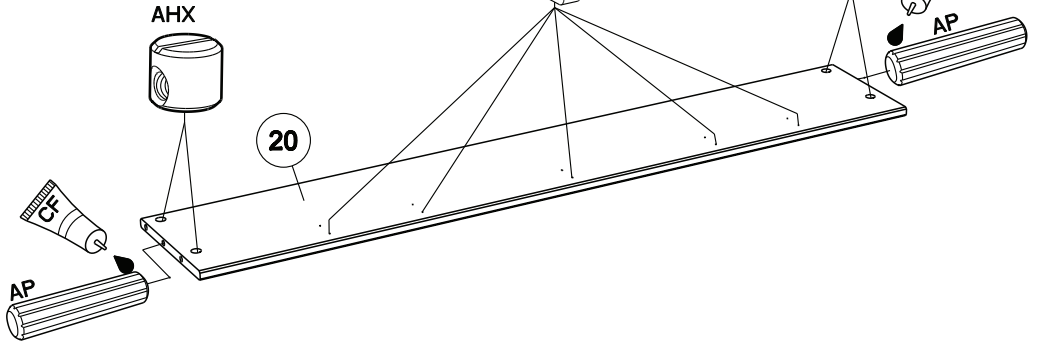

26

BML x 2

BLZ x 2

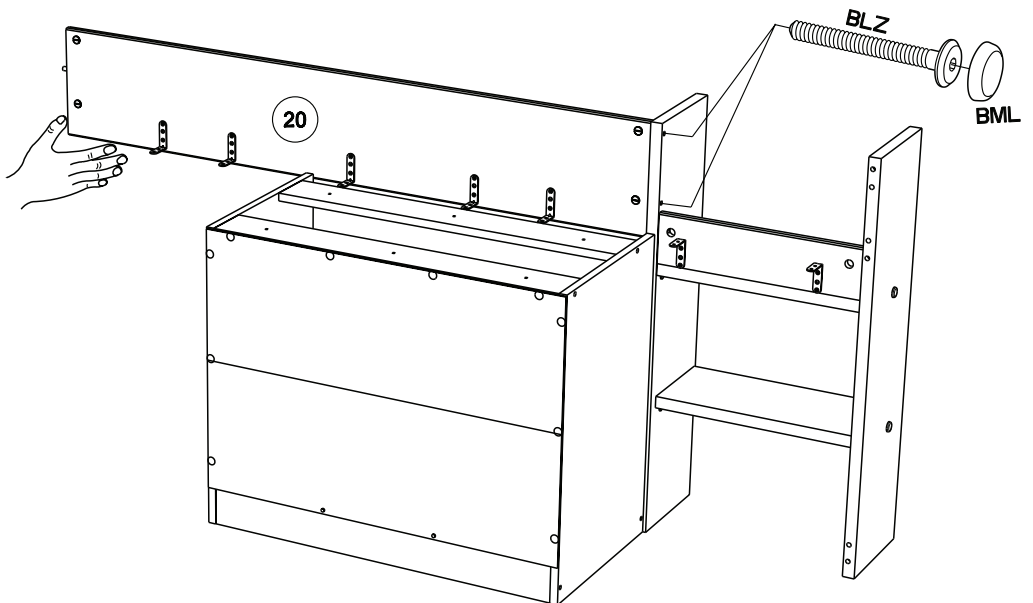
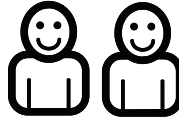

27



BML x 2



BLZ x 2

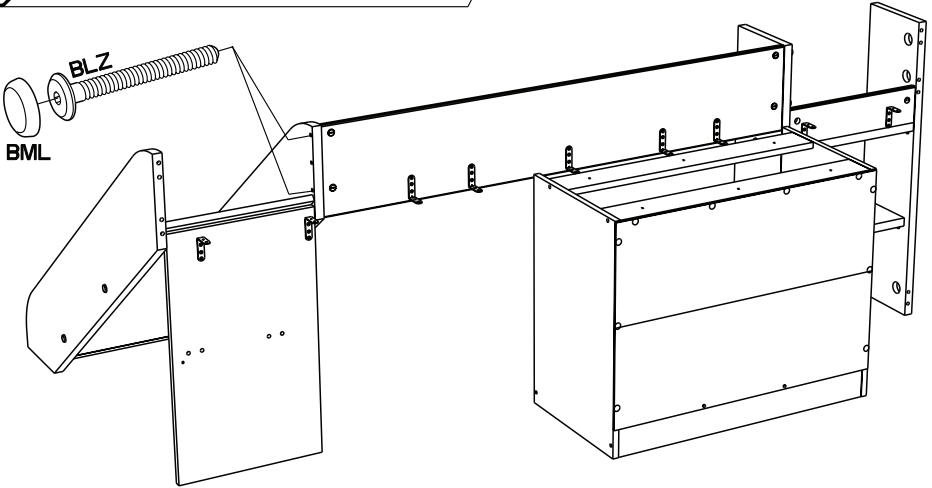

28



CF x 1



AP x 4



AHX x 3



VV x 2

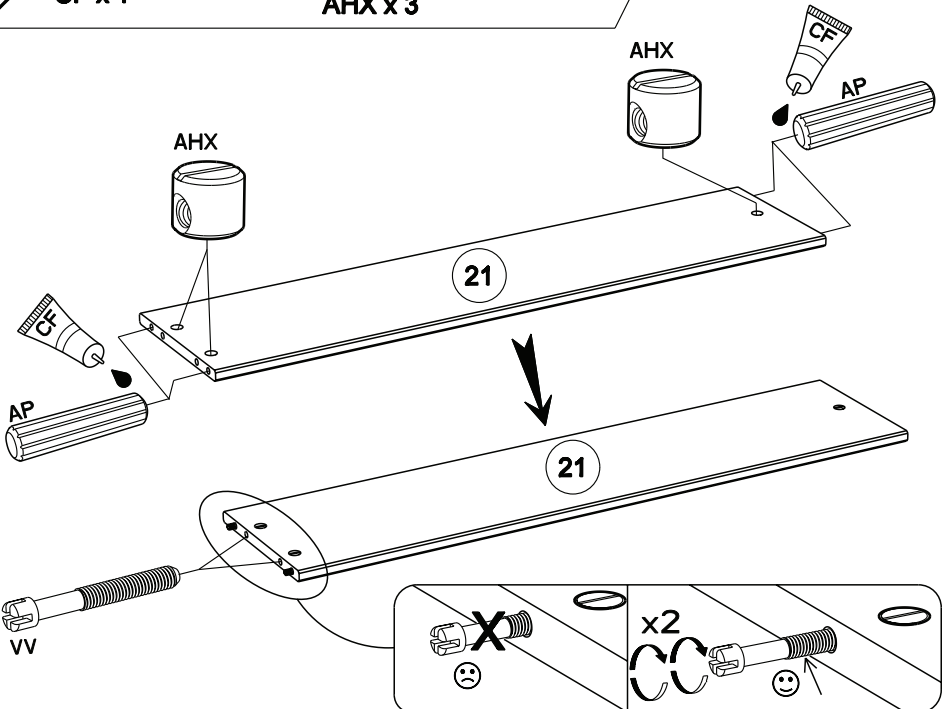

29

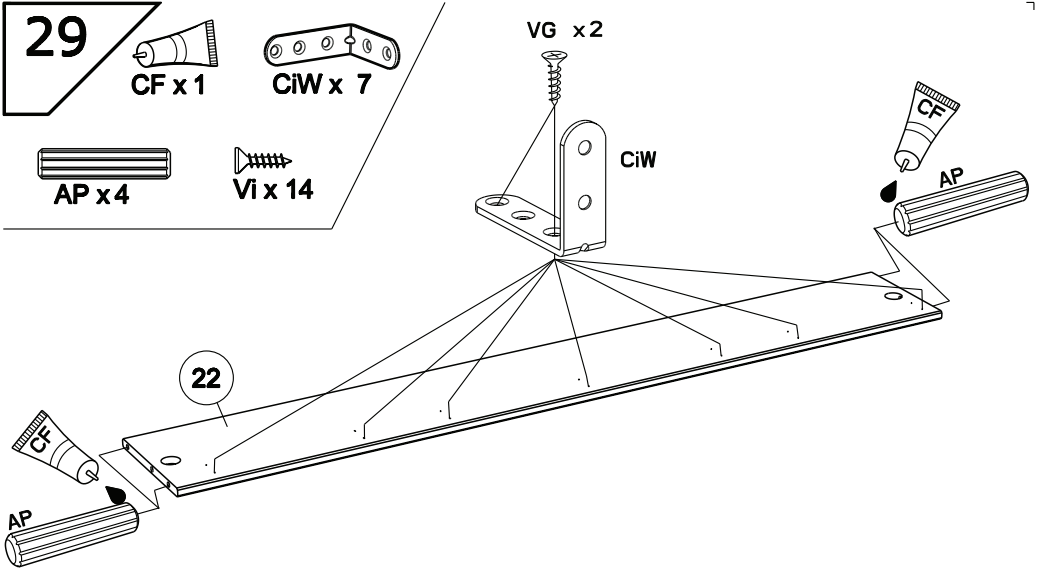

30

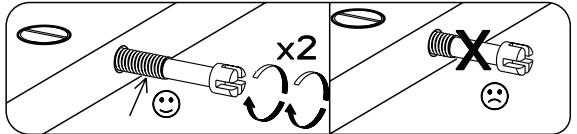
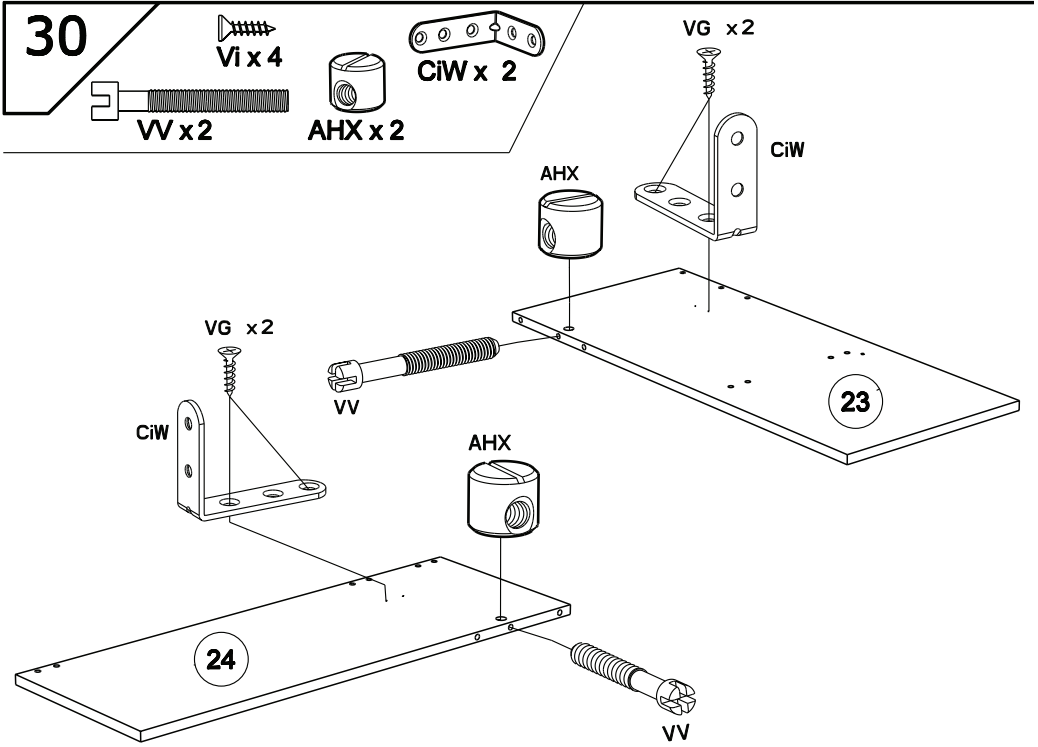
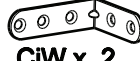

31



VW x 2

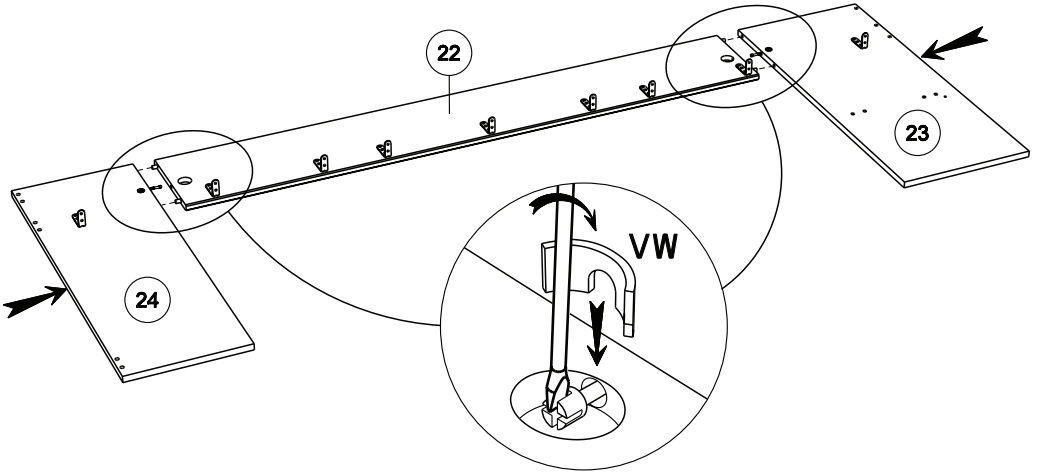

32



VW x 2

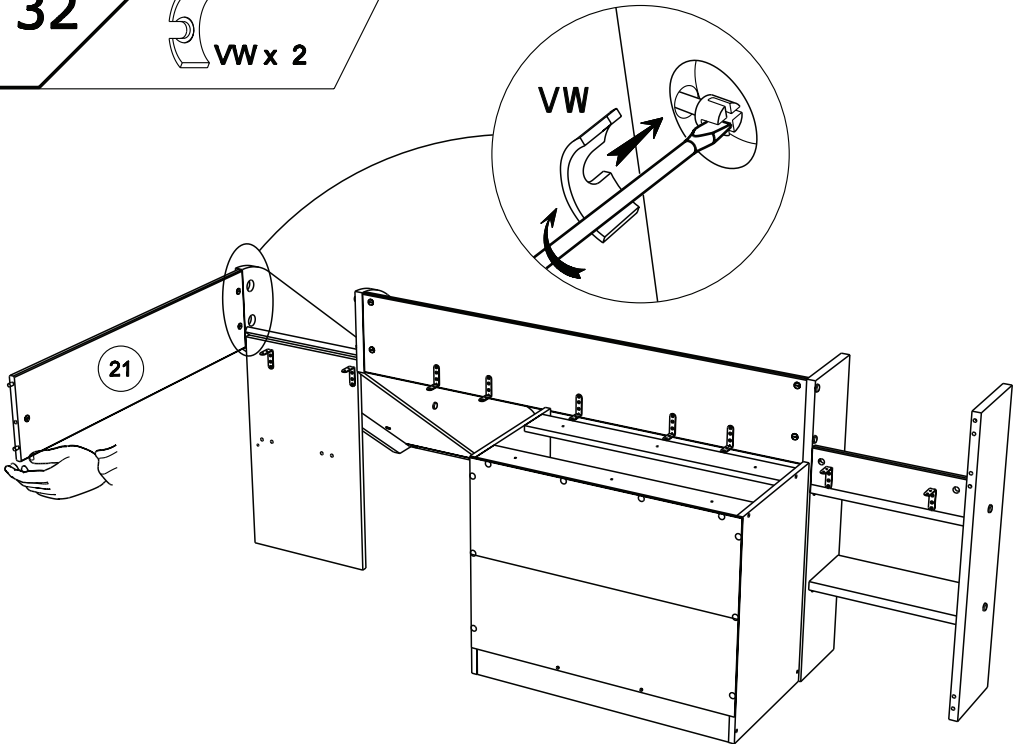

33



BLZ x 1

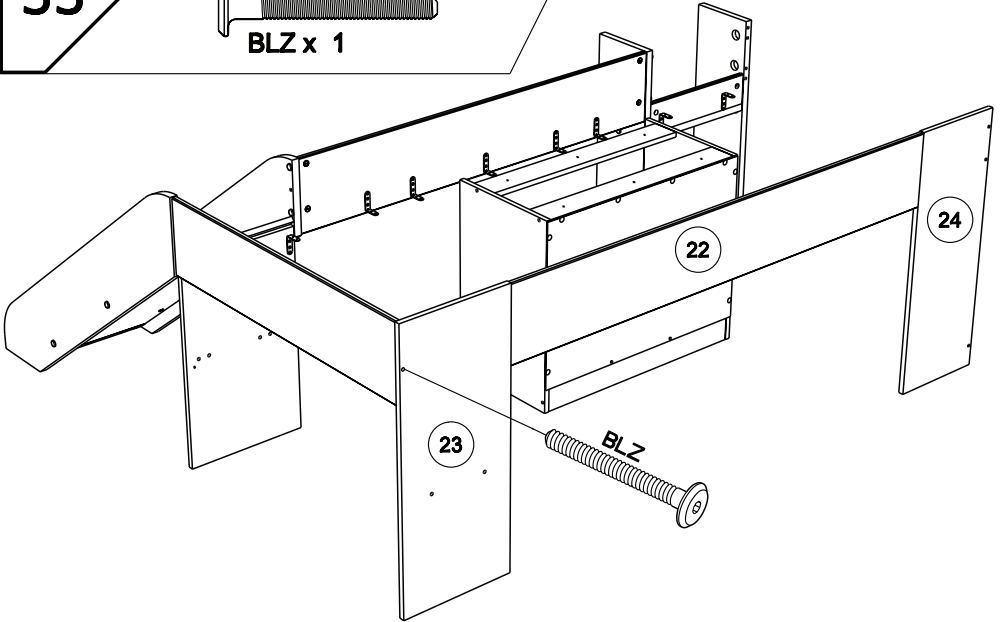

34



Aio x 2



AP x 4



AHX x 4



CF x 1

AHX



AP



25

AHX



AP



25

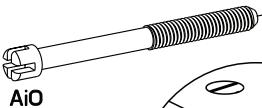

Aio

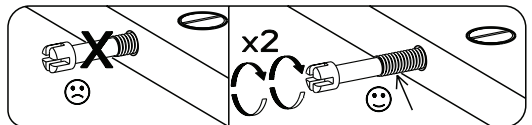
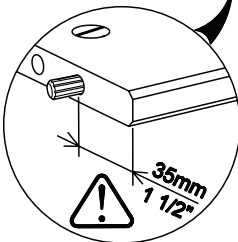



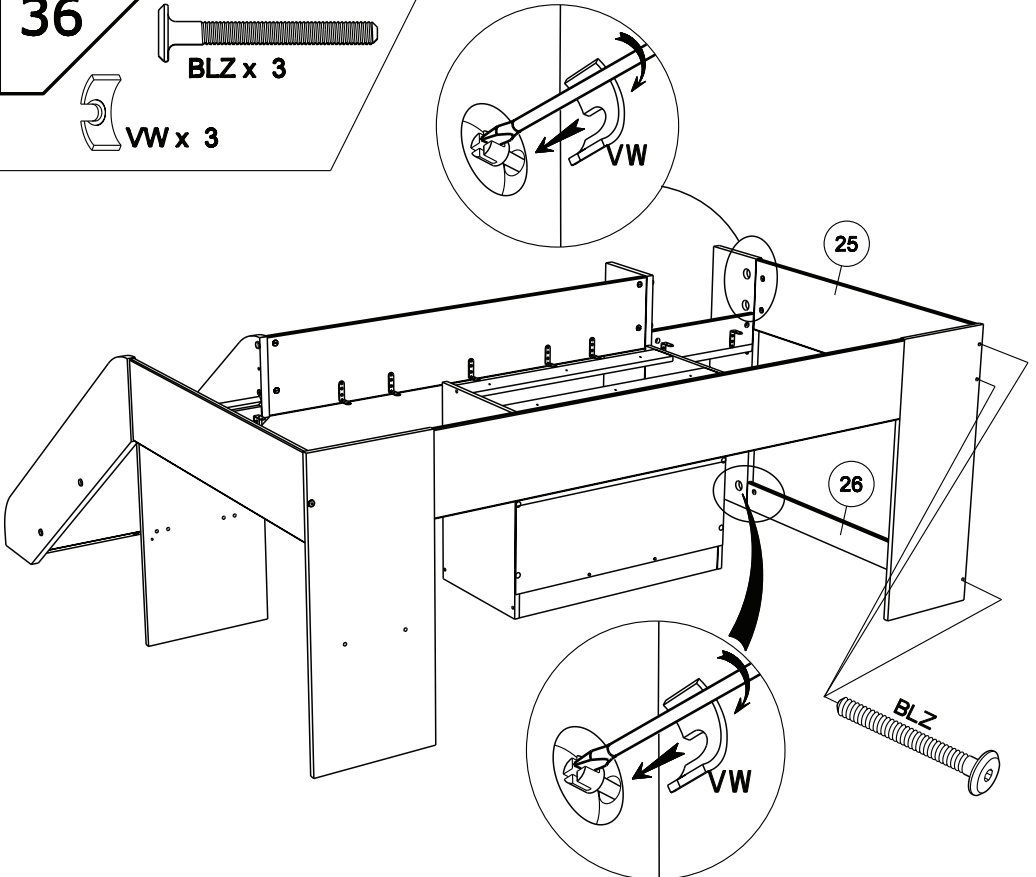
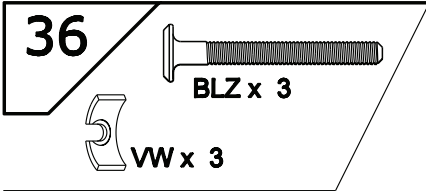
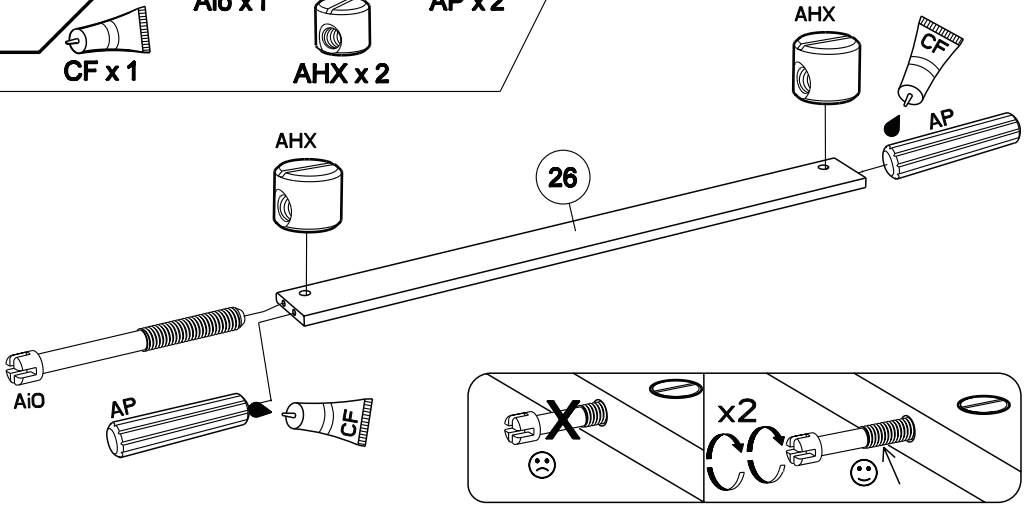
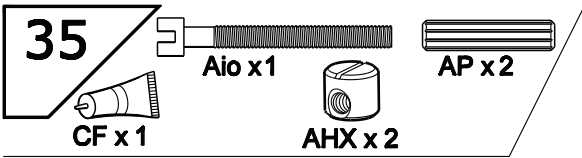

**37**

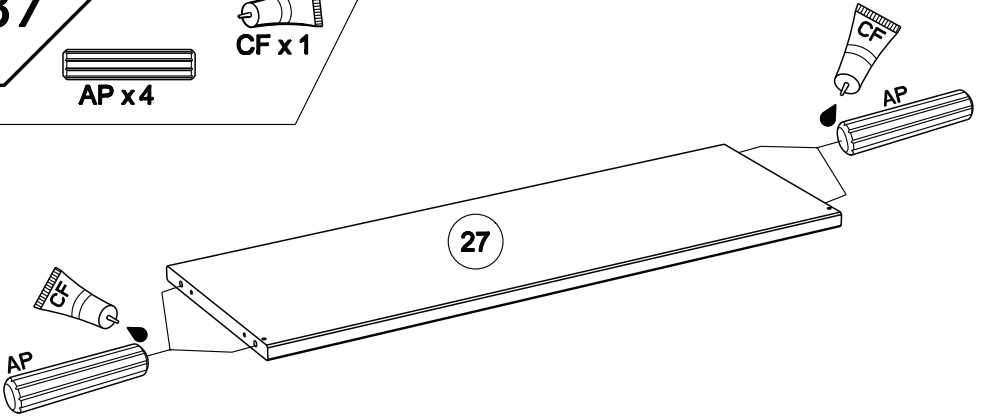

**38**

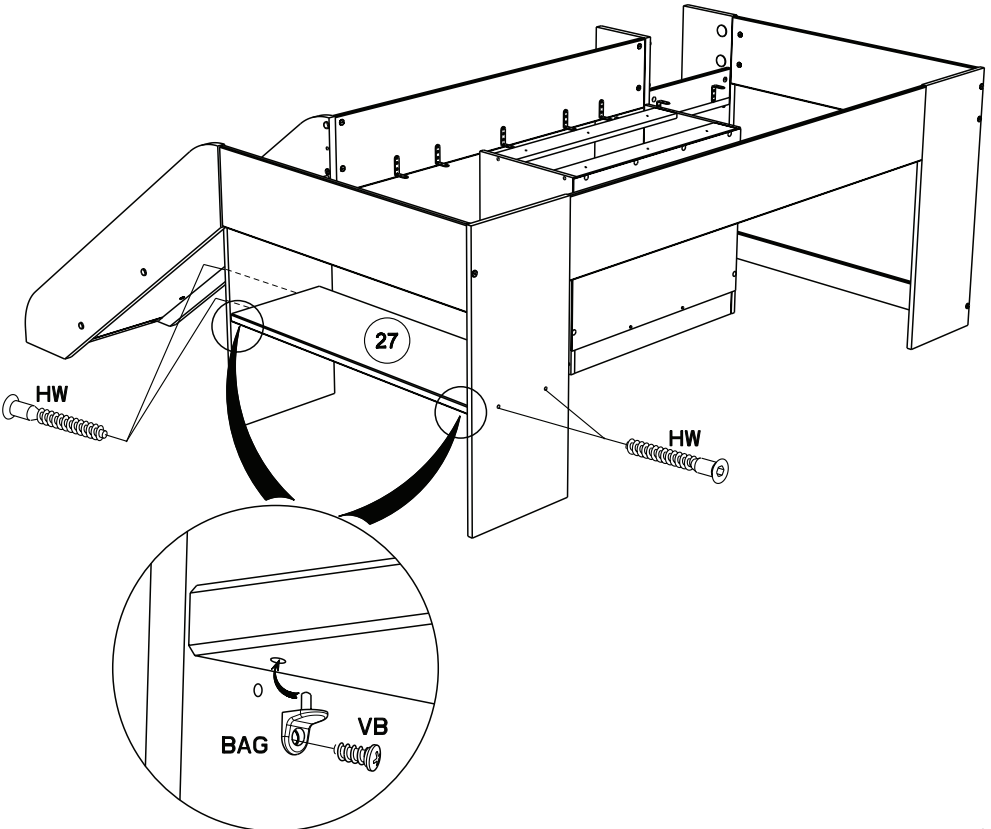
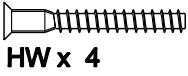

39

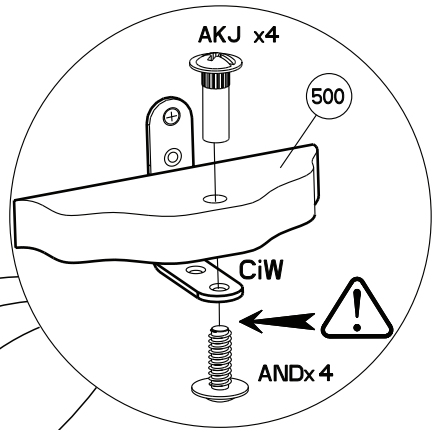
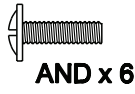
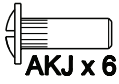

X 4

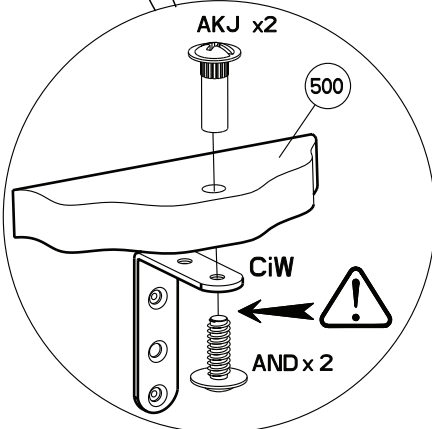
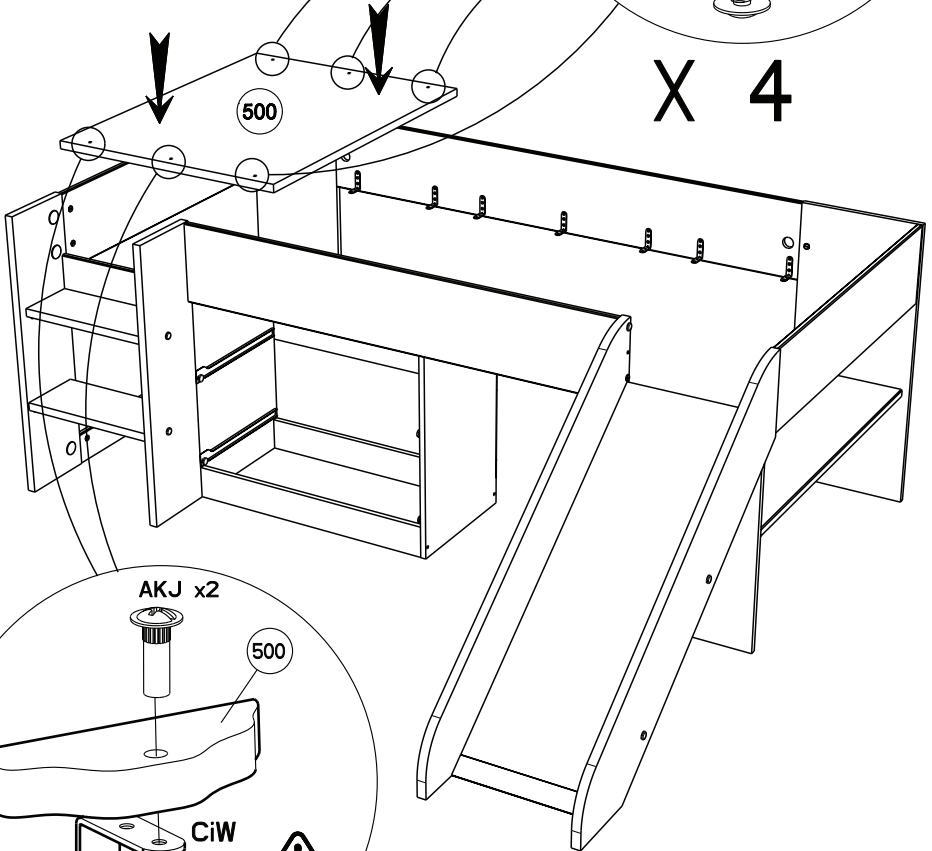

X 2

40

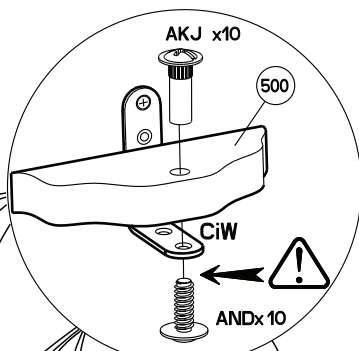

X 10

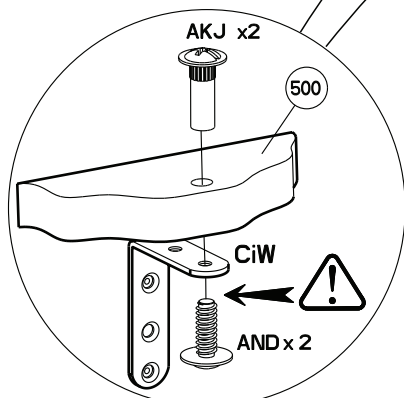
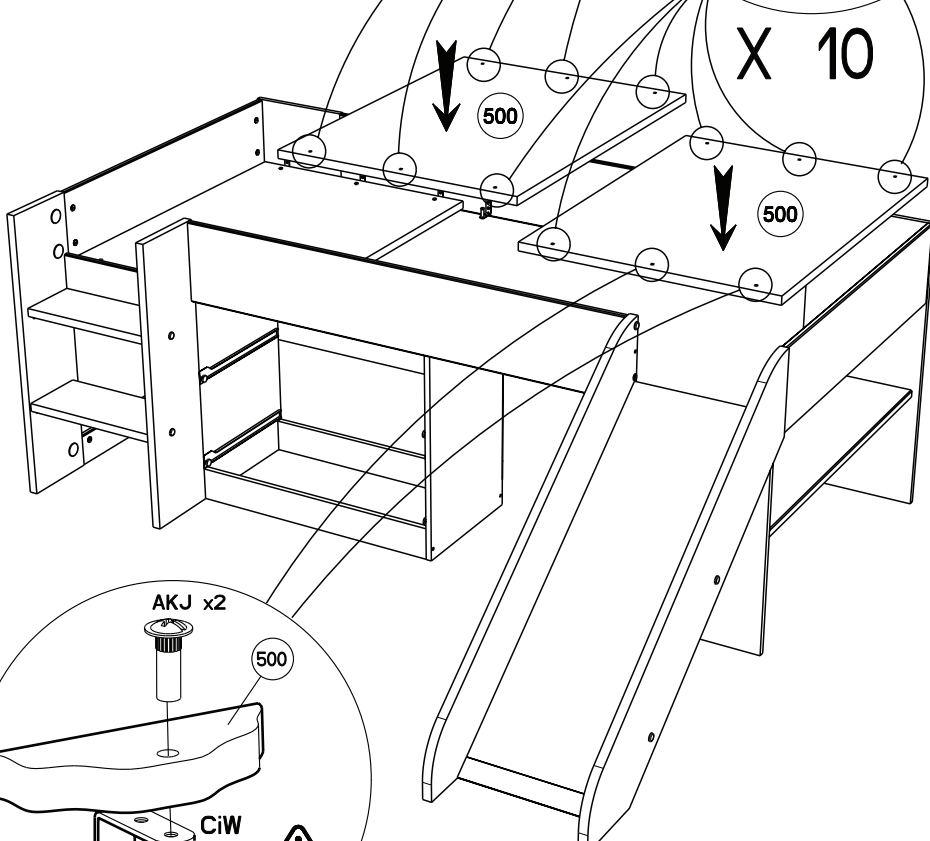

X 2

41

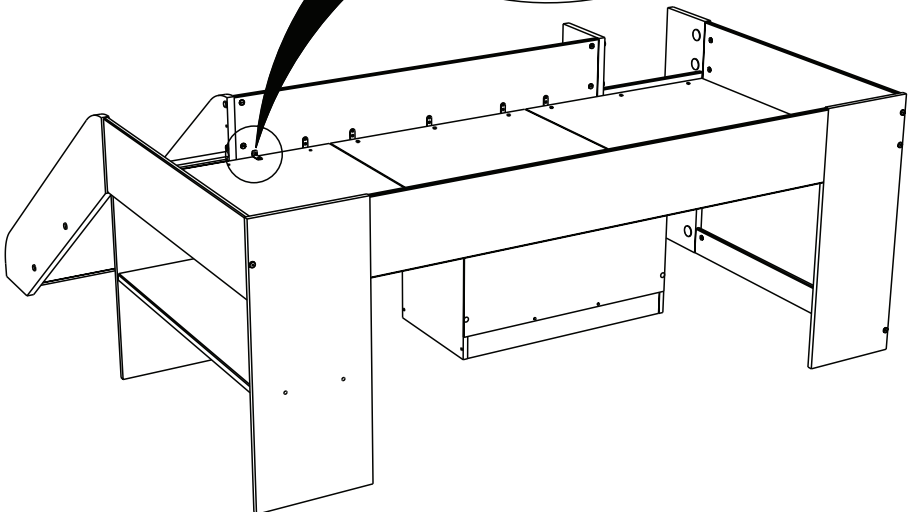
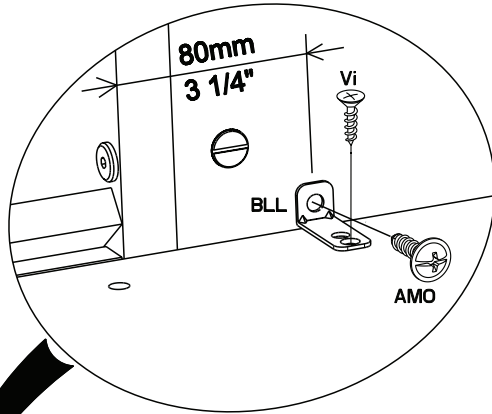
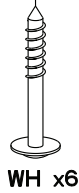
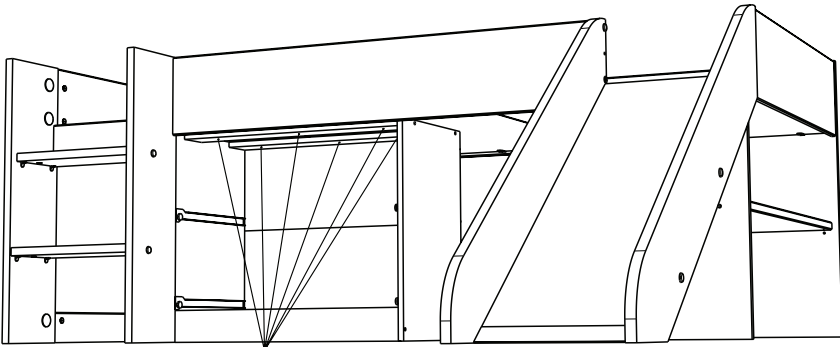
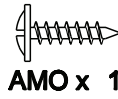
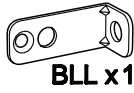
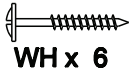

42

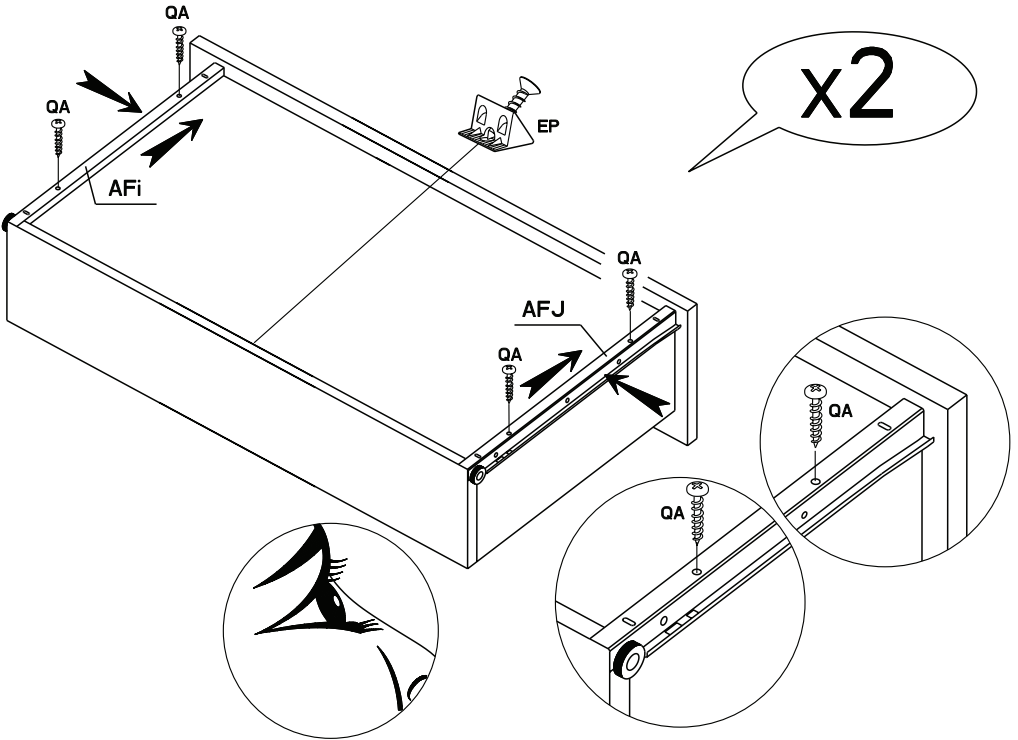
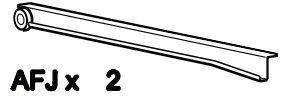
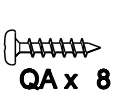

43

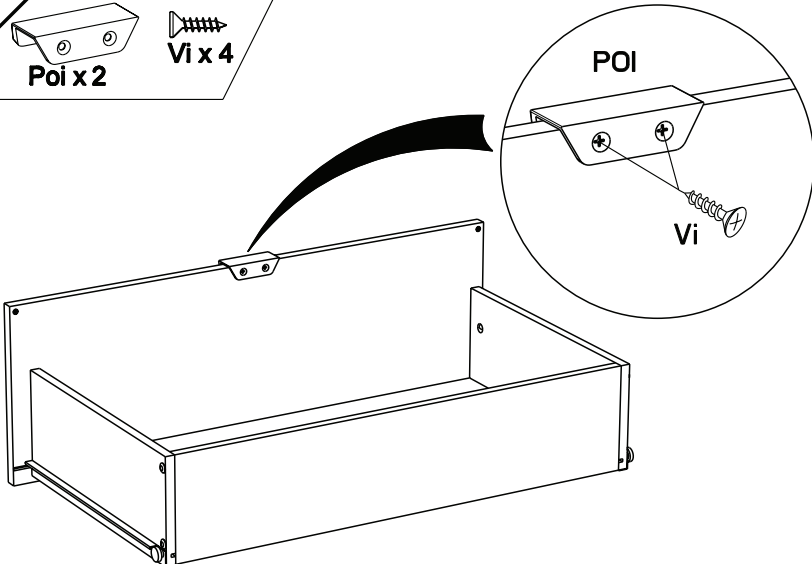

44



ADP x 7

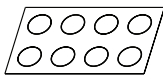

COL x 1

ADP



ADP



ADP



1°

AP

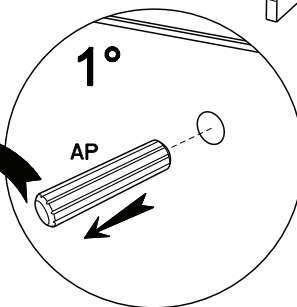

2°

COL

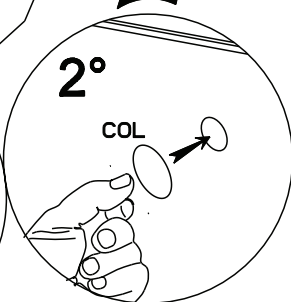

COL

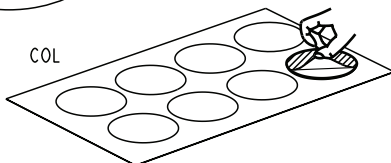

45

COL x 1

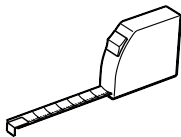
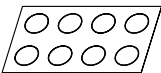

MAXI.

276mm  
10 3/4"

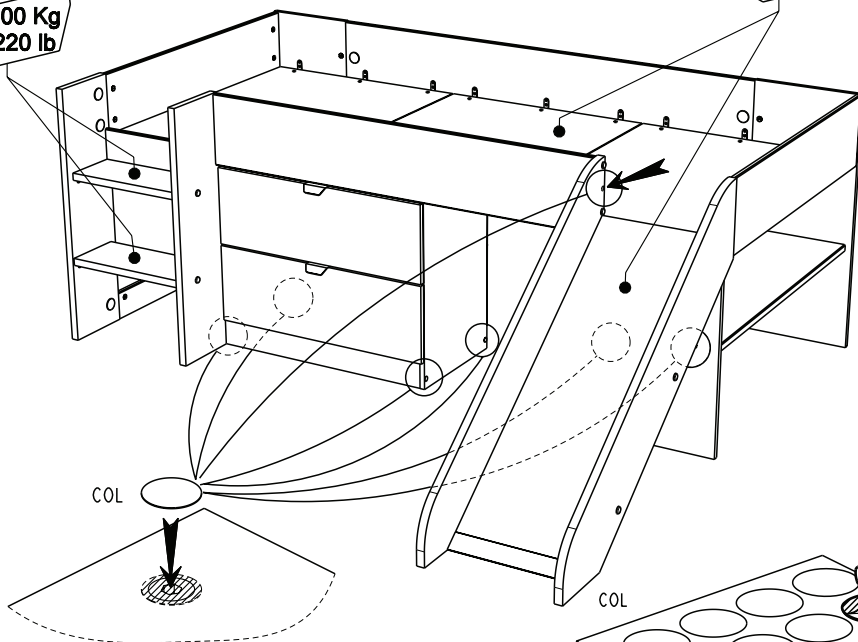
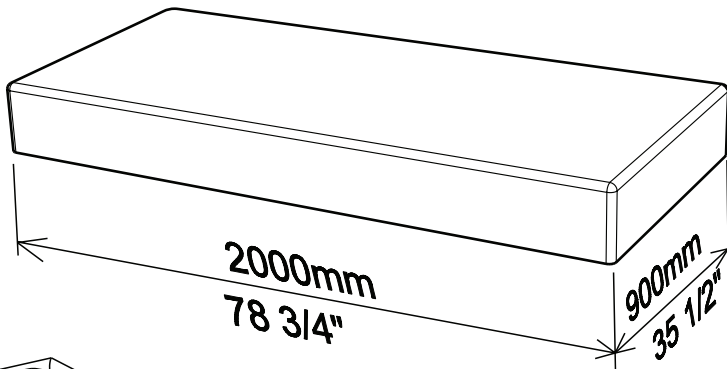

COL

COL

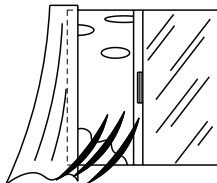

Après assemblage de ce produit, il est conseillé d'aérer régulièrement la pièce pendant quelques jours.  
After assembling this product, it is advisable to ventilate the room regularly for a few days.